

S600

Portable Compressed Air Purity Analyzer

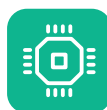

**ISO 8573-1
ALL IN ONE**
Particle concentration,
Dew Point, Oil vapor



**GUIDED
MEASUREMENT**
Software guided air
quality audits



**PORTABLE
MULTI-TOOL**
Can be carried
with one hand



**HIGH
PRECISION**
Accurate
measurements



**COMPACT
DESIGN**
Makes it
unique



**PDF
REPORTING**
Create ISO 8573-1
reports on the device



Benefits

- ✓ All-in-one device measures Particle concentration, dew point and oil vapor
- ✓ Measures additionally the temperature and pressure
- ✓ Software guided measurement makes it easy to generate reliable results
- ✓ Report generator creates PDFs for ISO 8573-1 audits
- ✓ Ultra portable and compact design

Plug & Play Measurement — Save Precious Time

ISO 8573 compliant purity quantifications of compressed air systems are bound to time-consuming installations and long-lasting test runs ... It's time for a revolution: The S600 is unlike its competition.

It combines the latest sensor technology, software-guided measurements and a time-saving setup into a handy, touchscreen controlled multi-tool. With our S600 you will finish measurement runs in much less time than with your traditional method, after that you don't ever want to leave your new comfort zone again. Trust us.

Remote connection

By connecting a LTE/4G modem to the designated USB port, S600 can be monitored remotely through S4A software.

Monitoring of All Relevant Contaminants



Particle Concentration Measurement

$0.1 < d \leq 0.5 \mu\text{m} / 0.5 < d \leq 1.0 \mu\text{m} / 1.0 < d \leq 5.0 \mu\text{m} / 5.0 \mu\text{m} < d$



Dew Point Measurement

-100 ... +20 °C Td



Oil Vapor Measurement

0.001... 5.000 mg/m³

ISO 8573-1 Classification

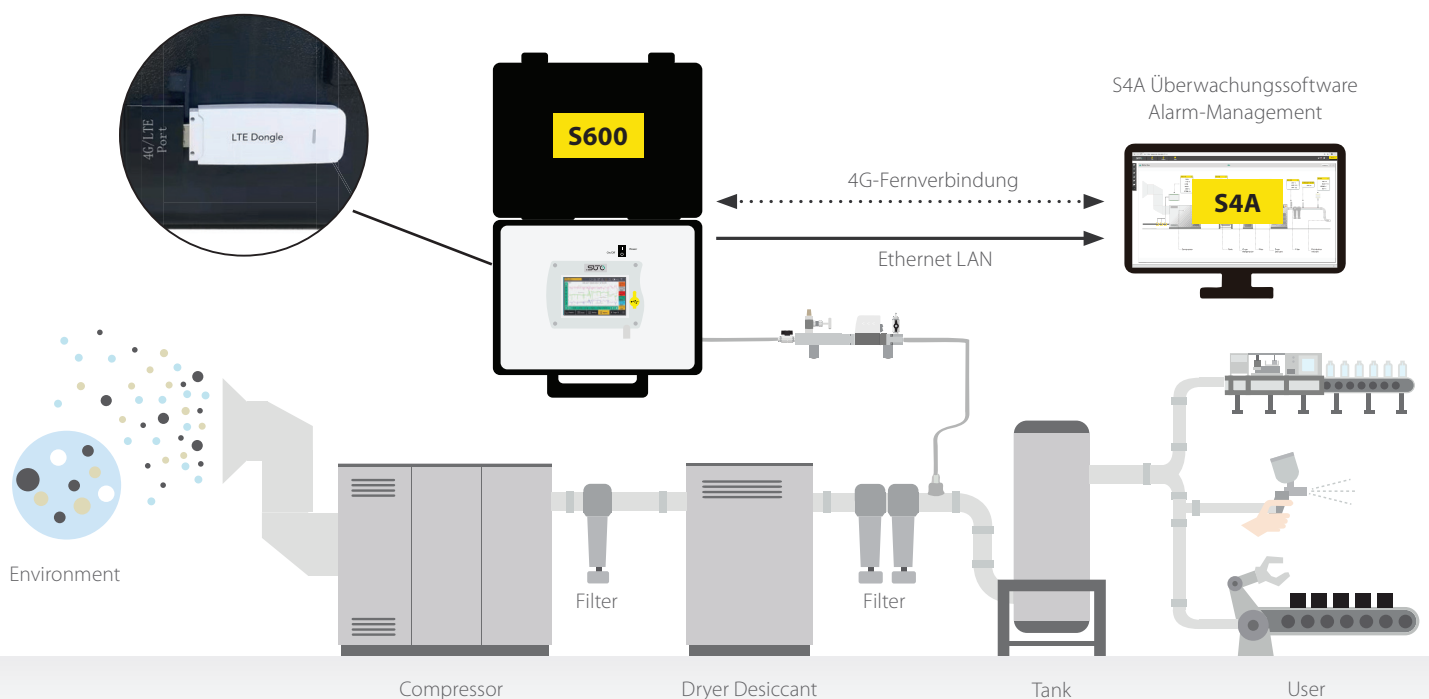

5 in 1 Measuring Device

The S600 is the portable multi-tool for ISO 8573-1 compressed air purity measurements. It measures, records and validates quality parameters like particle concentration, dew point, oil vapor contents, temperature and the pressure of compressed air systems.



Particle Concentration Measurement

- Measurement methods according to ISO 8573-4 standards (together with isokinetic sampling device)
- Latest laser detection technology
- Smallest particle size 30 ... 70 %, next bigger sizes 90 ... 110 % per ISO 21501-4



Dew Point Measurement

- Large ranges due to the unique multiple sensor technology
- Long-term stable and well-proven measurement methods
- High precision with an accuracy of ± 2 °C Td



Oil Vapor Measurement

- Latest photoionisation detector (PID) with self-calibration
- Measuring range according to ISO 8573-1 Class 1 to Class 5
- High precision with 5 % of reading ± 0.003 mg/m³ accuracy



Pressure Measurement

- State of the art sensor technology
- Additional quality data about the compressed air system



Integrated Data Logger

- Integrated data logger records all channels in parallel for later analysis
- 5" touchscreen allows you to interact with the device on site. There is no need for a PC to manage the device.

ISO 8573-4 Isokinetic Sampling Device

For particle measurements according to ISO 8573 an isokinetic sampling tube has been designed. This optional equipment enables you to monitor and adjust the air flow of the particle measurement to ensure the correct isokinetic sampling.

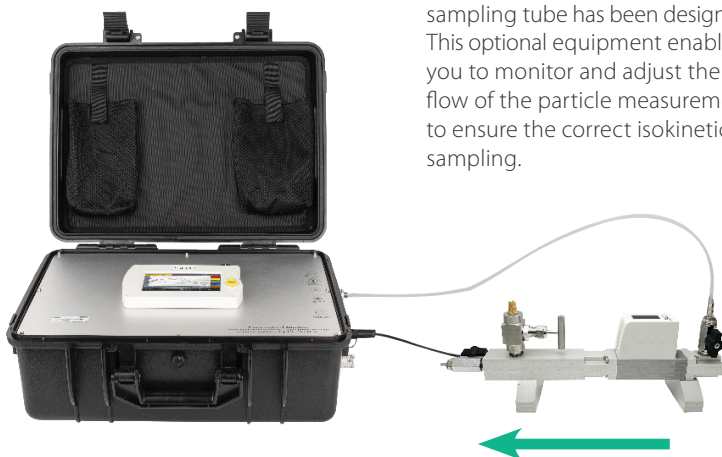

S600 Compressed Air Purity Analyzer

Applications

- ✓ Air quality measurements in medical, pharmaceutical, food and beverage applications
- ✓ Compressed air quality audits in regards to the ISO 8573-1
- ✓ Point-of-use measurements to ensure process safety and quality in all applications
- ✓ Monitoring of high tech applications with strict air purity requirements

Create Compressed Air Quality Reports

The S600 enables users to create powerful PDF reports directly on site. The reports are following the recommendations stated in the ISO 8573, additionally customer related data as well as service provider details can be entered on-screen, making it even easier to perform audits and to create meaningful reports.

PDF reports can be created from any recordings on the device and are copied on the fly to a connected USB drive for direct print-outs.

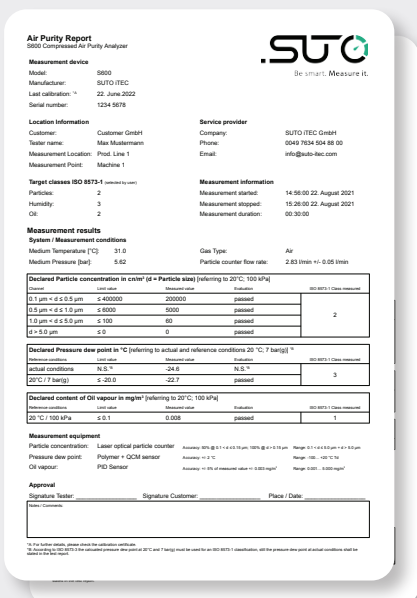

ISO 8573-1 Compressed Air Classes

ISO 8573-1:2010 is the main publication of the ISO 8573 series of standards, because it contains the permissible amount of contaminants per cubic meter of compressed air is fixed.

Class	Particle Concentration			Pressure Dew Point	Oil Concentration
	cn/m ³			°C (°F)	mg/m ³
	0.1 < d ≤ 0.5 μm	0.5 < d ≤ 1.0 μm	1.0 < d ≤ 5.0 μm		
0	As specified by the equipment user or supplier and more stringent than class 1				
1	≤ 20,000	≤ 400	≤ 10	≤ -70 (94.0)	≤ 0.01
2	≤ 400,000	≤ 6,000	≤ 100	≤ -40 (-40.0)	≤ 0.1
3	not specified	≤ 90,000	≤ 1,000	≤ -20 (-4.0)	≤ 1
4	not specified	not specified	≤ 10,000	≤ +3 (+37.4)	≤ 5
5	not specified	not specified	≤ 100,000	≤ +7 (+45.6)	> 5
6	x	x	x	≤ +10 (+50.0)	x

Why should you focus on your ISO 8573-1 specifications?

Certain industries like the pharmaceutical and food industry requires high-quality compressed air. By meeting the ISO 8573-1 standard requirements you can:

- ✔ **Ensure Process and Product Safety:**
 Potential incidents, like contaminants meeting food via water and oil, can create safety concerns and unreliable processes.
- ✔ **Avoid Production Failures and Poor Quality Finishes:**
 Contaminants mixing with applications effect product results.
- ✔ **Prevent production downtime:**
 Processes and machines are stopped to find and eliminate the contamination issues.

Dimensions

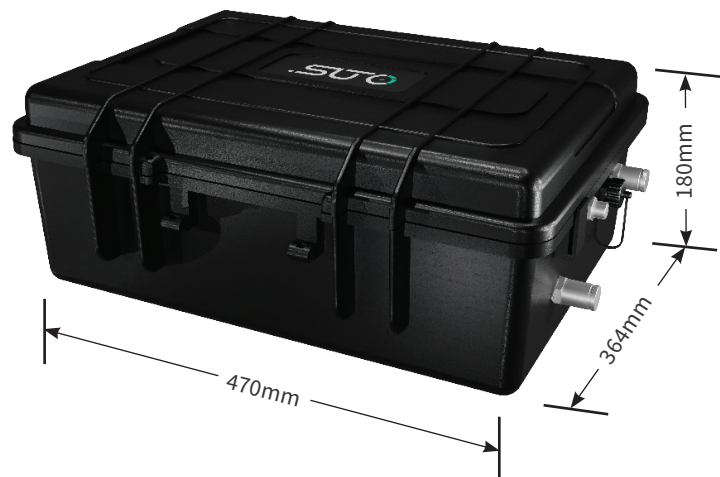

Technical Data

Measurement

Particle concentration

Accuracy	Counting Efficiency according ISO 21501-4 30 ... 70 % of $d > 0.1 \mu\text{m}$ 90 ... 110 % of $d \geq 0.3 \mu\text{m}$
----------	---

Selectable units	$\text{cn}/\text{m}^3, \text{cn}/\text{ft}^3$
------------------	---

Measuring range	$0.1 < d \leq 0.5 \mu\text{m}$
	$0.5 < d \leq 1.0 \mu\text{m}$
	$1.0 < d \leq 5.0 \mu\text{m}$
	$5.0 \mu\text{m} < d$

Sensor	Laser optical particle counter
--------	--------------------------------

Sampling rate	1 min.
---------------	--------

Flow rate	2.83 l/min
-----------	------------

Pressure Dew Point

Accuracy	$\pm 1 \text{ }^\circ\text{C Td}$ (0 ... 20 $^\circ\text{C Td}$)
	$\pm 2 \text{ }^\circ\text{C Td}$ (-70 ... 0 $^\circ\text{C Td}$)
	$\pm 3 \text{ }^\circ\text{C}$ (-100 ... -70 $^\circ\text{C Td}$)

Selectable units	$^\circ\text{C}, ^\circ\text{F}$
------------------	----------------------------------

Measuring range	-100 ... +20 $^\circ\text{C Td}$
-----------------	----------------------------------

Sensor	QCM + Polymer
--------	---------------

Response time (t90)	-20 $^\circ\text{C Td}$ -> -60 $^\circ\text{C Td}$ = < 240 sec
	-60 $^\circ\text{C Td}$ -> -20 $^\circ\text{C Td}$ = < 30 sec @ 4 l/min

Oil vapor

Accuracy	5 % of value +/- 0.003 mg/m^3
----------	---

Detection limit	0.001 mg/m^3
-----------------	------------------------------

Resolution	0.001 mg/m^3
------------	------------------------------

Selectable units	mg/m^3
------------------	------------------------

Measuring range	0.001 ... 5.000 mg/m^3
-----------------	--

Sensor	PID (Photoionisation detector)
--------	--------------------------------

UV lamp lifetime	1 year or 6000 working hours, whichever comes first
------------------	---

Sampling rate	1 sec.
---------------	--------

Pressure

Accuracy	0.5 % FS
----------	----------

Measuring range	0.1 ... 1.6 MPa(g)
-----------------	--------------------

Sensor	Piezo resistive sensor
--------	------------------------

Temperature

Accuracy	$\pm 0.3 \text{ }^\circ\text{C}$
----------	----------------------------------

Measuring range	0 ... + 50 $^\circ\text{C}$
-----------------	-----------------------------

Sensor	Pt100
--------	-------

Reference conditions

Selectable conditions	ISO1217 20 $^\circ\text{C}$ 1000 mbar
-----------------------	---------------------------------------

Signal / Interface & Supply

Fieldbus

Protocol	Modbus/TCP
----------	------------

Update rate	1 / sec.
-------------	----------

Power Supply

Voltage supply	Mains supply adapter (AC/DC)
	Input: 100 ... 240 VAC, 50/60 Hz, 1.4 A
	Output: 24 VDC, 2.5 A, 60 W max.

Current consumption	1.4 A
---------------------	-------

Interface

USB	USB Micro with OTG support
-----	----------------------------

LTE/4G USB	USB Port for 4G/LTE Modem
------------	---------------------------

General data

Configuration

Others	Device comes pre-configured Configuration can be done via on-screen touch
--------	--

Display

Integrated	Touchscreen, Size: 5", Resolution: 800 x 480 px
------------	---

Data Logger

Storage	Up to 3 million recorded data sets (10 channels each)
---------	---

Report	Integrated report generator for PDF export
--------	--

Material

Process connection	Brass nickel-plated, FKM
--------------------	--------------------------

Housing	PC + ABS, Al alloy
---------	--------------------

Miscellaneous

Electrical connection	2-Pin, push-pull socket
-----------------------	-------------------------

Protection class	IP54 (cover lid closed)
------------------	-------------------------

Approvals	CE
-----------	----

Process connection	Micro quick connector, full passthrough, male (1.5 m hose with coupling included)
--------------------	---

Weight	9.8 kg
--------	--------

Operating conditions

Medium	Compressed Air, Nitrogen N_2 , Carbon dioxide CO_2 (software setting)
--------	---

Medium quality	ISO 8573-1: 4.5.4 or better
----------------	-----------------------------

Medium temperature	0 ... + 50 $^\circ\text{C}$
--------------------	-----------------------------

Medium humidity	Medium humidity < 40 % rH, no condensation
-----------------	--

Operating pressure	0.3 ... 1.5 MPa(g)
--------------------	--------------------

Ambient temperature	0 ... +50 $^\circ\text{C}$
---------------------	----------------------------

Ambient humidity	0 ... 90 % rH
------------------	---------------

Storage temperature	-10 ... + 50 $^\circ\text{C}$
---------------------	-------------------------------

Transport temperature	-10 ... + 50 $^\circ\text{C}$
-----------------------	-------------------------------

Isokinetic Sampling Device

Measurement

Isokinetic Sampling Device

Measuring unit	Measuring unit Sampling pipe with integrated isokinetic sampling tube, flow regulation and control by integrated flow sensor, to be used for particle measurements according to ISO 8573-4
Flow meter unit	Thermal mass flow meter (only for isokinetic flow setup, no system flow measurement)
Sensor	Thermal mass flow sensor
Accuracy	3 % o. RDG

Signal Interface & Supply

Connection	Communication to S600 (cable included)
Update rate	1 / sec.

General data

Material

Process connection	Brass nickel-plated, FKM
Housing	PC + ABS, Al alloy
Main unit	Al alloy
Isokinetic tube	Stainless steel 1.4404 (SUS 316L)

Miscellaneous

Electrical connection	M8
Protection class	IP54
	IEC 61326-1
Process connection	Micro quick connector, full passthrough, male (1.5 m hose with coupling included)

Operating conditions

Medium	Compressed Air, Nitrogen N ₂ , Carbon dioxide CO ₂ (software setting)
Medium quality	ISO 8573-1: 4.5.4 or better
Medium temperature	0 ... + 40 °C
Medium humidity	Medium humidity < 40 % rH, no condensation
Operating pressure	0.3 ... 1.5 MPa(g)
Ambient temperature	0 ... +50 °C
Ambient humidity	0 ... 90 % rH
Storage temperature	-10 ... + 70 °C
Transport temperature	-10 ... + 70 °C

Dimensions Isokinetic Sampling Device

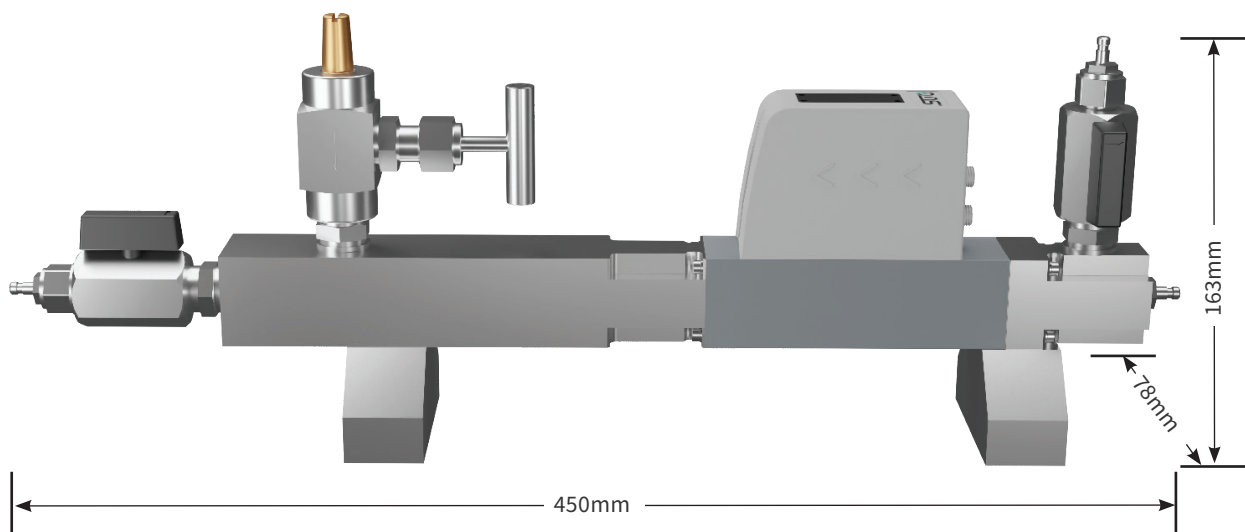

Please use the following tables to assist in placing your order with our sales staff.

S600 Portable Compressed Air Purity Analyzer (Portable Version)

Order No.	Description
P560 0600	<p>Touch screen interface, data logger, guided measurement, PDF report generator, USB port and Ethernet port with Modbus/TCP Particle d: $0.1 < d \leq 0.5, \mu\text{m}$ $0.5 < d \leq 1.0 \mu\text{m}$, $1.0 < d \leq 5.0 \mu\text{m}$, $d > 5.0 \mu\text{m}$ Dew point: $-100 \dots +20 \text{ }^\circ\text{C Td}$ Oil vapor: $0.001 \dots 5.000 \text{ mg/m}^3$</p> <p><u>Including:</u></p> <ul style="list-style-type: none"> • Portable Compressed Air Purity Analyzer in a hand carry case with handle and shoulder belt • USB OTG memory stick • Purge filter for pre-measurement (test kit) • Power supply, 230 VAC / 24 VDC 50/60 Hz • 2 x Connection hose 1.5 m, one end quick coupling, one end compressed air coupling • Certificate of calibration • Operation and instruction manual
A1670	USB 4G dongle for S551/S600, including S4A software

Isokinetic Sampling Device

Order No.	Description
A554 0600	<p>Isokinetic sampling device for particle measurement according to ISO 8573</p> <p><u>Including:</u></p> <ul style="list-style-type: none"> • Isokinetic sampling pipe • Flow sensor mounted on pipe • Certificate of calibration • Connection cable to S600 • Connection hose 150 mm, both ends quick coupling • Connection hose 700 mm, both ends quick coupling • Connection hose 1.5 m, one end quick coupling, one end compressed air coupling • Transport case to carry the device, hoses and cables

