



AdsoMax
FOR MAXIMUM ADSORPTION



Be smart. Measure it.

NEXT LEVEL OF COMPRESSED AIR, GAS AND LIQUID MONITORING

- PRODUCT GUIDE



INSTRUMENTS
VALVES



Introduction



Company Overview

Founded in year 1980, Kompauto has emerged as a dynamic force in developing its market for cutting-edge measurement instruments and systems for the Scandinavian market. With a primary focus on providing comprehensive solutions for accurate measurements of flow rates and quality parameters across various fluids like compressed air, gases and liquids/water. Kompauto continuously drives innovation to meet the evolving needs of industries worldwide.

Kompauto's extensive product portfolio encompasses a range of solutions tailored to meet the unique demands of its clientele:

Key Products and Solutions

Flow, Pressure, Level and Temperature Instruments

Kompauto's precision instruments employ advanced sensor technology to deliver accurate measurement data of compressed air, gases, liquids, and water. Real-time data provided by these meters empowers industries to optimize processes, enhance efficiency, and minimize energy consumption.



Quality Monitoring Systems

Quality monitoring systems act as guardians, ensuring the purity and integrity of compressed air, gases and liquids/water. By detecting contaminants, impurities, and moisture, these systems uphold consistent product quality and prevent equipment deterioration.



Calibration Services

Kompauto's calibration services thru their manufacturers ensures accuracy to signify adherence to industry standards and regulations, reflecting the company's commitment to precision and reliability.

Valve Technology

Kompauto's innovative valve solutions stand as a testament to the company's diverse capabilities. These valves play a pivotal role in controlling the flow of compressed air, gases, liquids, and water, contributing to efficient operations and enhanced safety.

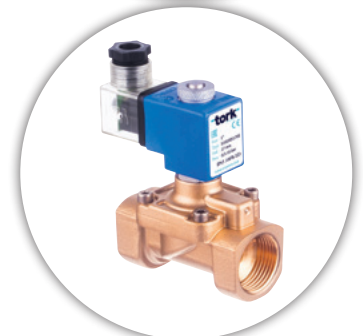

Custom Solutions

Acknowledging the unique requirements of different industries, Kompauto excels in developing customized measurement solutions that precisely cater to specific applications, transcending limitations to deliver optimal outcomes.





Scope of Industries



Industry Applications:

Kompauto's products find relevance in a diverse array of industries, including:

Manufacturing: Enhancing production processes by accurately measuring the quality of compressed air, gases, liquids, water, and ensuring precise valve control.

Pharmaceuticals: Safeguarding pharmaceutical processes by monitoring the purity of gases, liquids, water, and efficiently controlling valves to maintain stringent quality standards.

Energy: Optimizing energy consumption through precise flow measurements of gases, liquids, water, and effective valve management in power generation facilities.

Food and Beverage: Ensuring the safety and quality of beverages, dairy products, processed foods, and efficient valve control.

Petrochemicals: Protecting equipment and refining processes through flow rate and quality monitoring of gases and liquids, as well as valve management in refineries and chemical plants.

Water Distribution Networks: Kompauto's impact extends to the realm of water distribution networks, where accurate flow measurement is pivotal. In this vital domain, Kompauto's flow meters and monitoring systems aid municipalities and utilities in effectively managing water resources. By ensuring precise measurements and identifying leaks, these solutions contribute to efficient water distribution, conservation, and cost reduction. As water scarcity becomes increasingly pressing, Kompauto's role in optimizing water distribution networks gains unparalleled significance.

Summary

Kompauto's impact spans the spectrum of precision fluid measurement and quality control across compressed air, gases, liquids in industrial processes and water distribution. With an unyielding commitment to innovation, precision engineering, and customer satisfaction, Kompauto continues to elevate industries. It drives progress, efficiency, and excellence, firmly establishing itself as a beacon of advancement in the ever-evolving industrial landscape.



This book

The content of this book is dedicated to highlighting our expertise in applications involving compressed air, gases and water. Explore our cutting-edge solutions and precision measurement technologies tailored to optimize efficiency and quality in these vital domains.



Advanced Measurement



Compressed Air and Gas Monitoring - get your system under control

The use of compressed air and technical gases in modern production processes has become indispensable. Compressed air is used to drive actuators, machines and to control other automated processes. Technical gases and air are used to conserve food or are even becoming part of the product, like in the beverage production.

This leads to two crucial aspects:

1

Energy Consumption

Air compressors typically convert ~80 ... 90 % of the electrical energy into heat and only 10 ... 20 % into compressed air. This makes compressed air 5 to 10 times more expensive than electricity. Measuring and Monitoring compressors, the consumptions, pressure and flow rates becomes major part in a world with limited energy resources.

2

Purity and Quality

Having air and gases becoming a part of your product and process means, that we need to have a control system in place, insuring that filtration systems are working as they should, 24 hours a day, 7 days a week. Only by regular measurements or by using monitoring solutions this can be achieved.

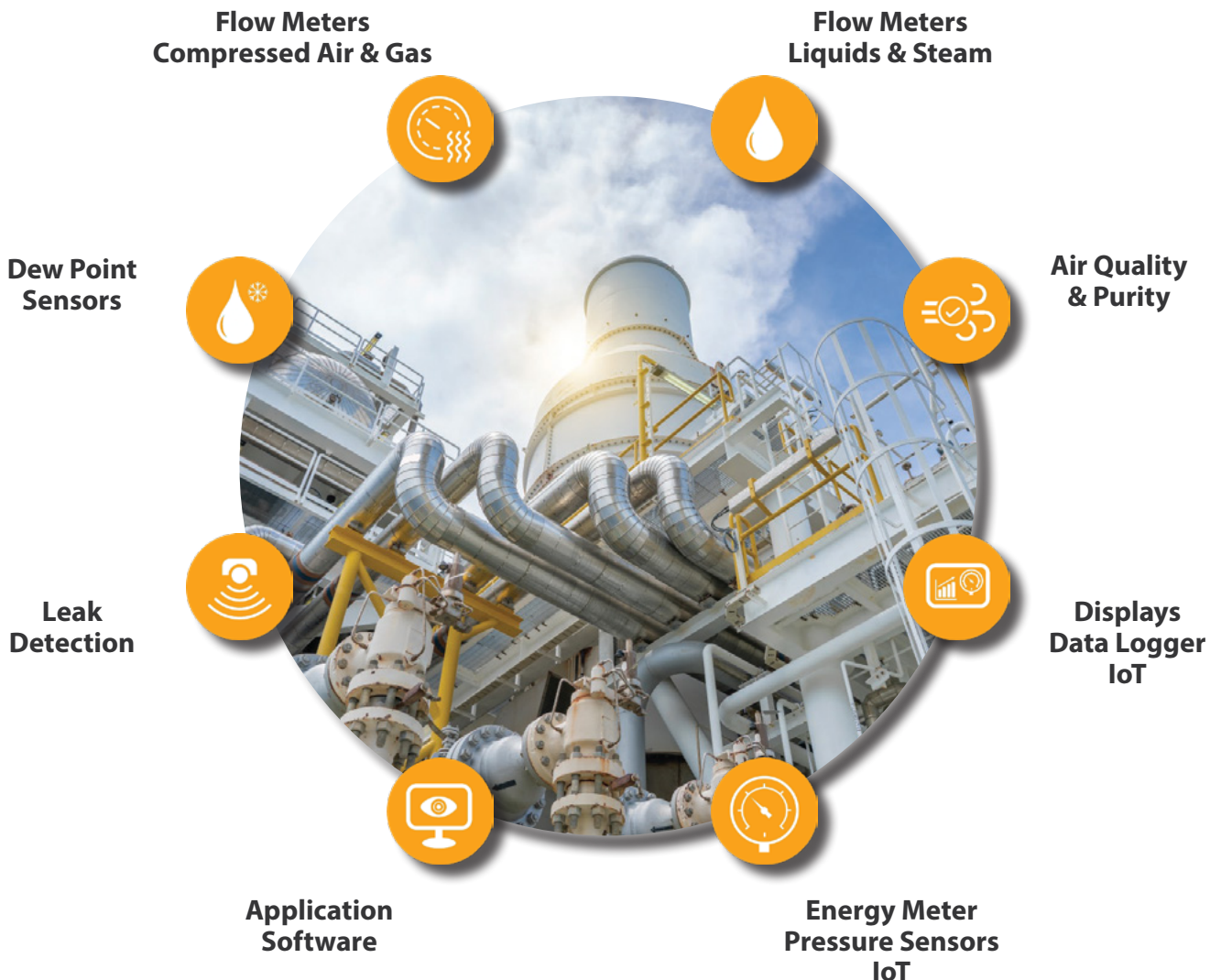

Table of Contents



Description	Article series	Page
Introduction of Kompauto		2-3
Advanced Measurement - Table of Contents		4-5
Flow and Consumption Sensors for Air and Gases		
Thermal Mass Flow Meter (Insertion and Inline)	SUTO S401 Insertion / S421 Inline	6-13
Compact Thermal Mass Flow Meter (Eco-Inline)	SUTO S415	14-19
Compact Thermal Mass Flow Meter (Pro-Inline)	SUTO S418	20-25
Compact Thermal Mass Flow Meter for Vacuum Applications (Inline)	SUTO S418-V	26-31
Thermal Mass Flow Meter for Heavy Duty and Ex Applications	SUTO S451 Insertion / S453 Inline	32-39
Pitot Tube Flow Meter for Wet Air	SUTO S430 Insertion	40-45
Thermal Mass Flow Direction Switch	SUTO S409 Insertion	46-49
Flow and Consumption Sensors for Liquids and Steam		
Vortex Flow Meter for Steam	SUTO S435 Inline	50-53
Ultrasonic Flow Meter for Liquids (Clamp-on)	SUTO S461 Clamp-on	54-58
Compact Ultrasonic Flow Meter for Liquids (Clamp-on)	SUTO S462 Clamp-on	59-62
Dew Point Sensors for Compressed Air and Gases		
Dew Point Transmitters	SUTO S211 / S215 / S220	63-67
Dew Point Transmitters for Ex Applications	SUTO S230 / S231	68-71
Dew Point Monitor (-50 ... +20 °C Td / -20 ... +50 °C Td)	SUTO S305	72-75
Portable Dew Point Meter (-100 ... +50 °C Td)	SUTO S520	76-80
Displays and Data Loggers		
Display and Data Logger	SUTO S330 / S331	81-87
Display	SUTO S320	88-90
Portable Display and Data Logger	SUTO S551	91-97
Application Software and Mobile Apps		
SaaS Smart Compressed Air System Monitoring Software	SUTO S4M	98-104
Data Analysis Software	SUTO S4A	105-106
Smartphone App for Air and Gas Flow Meter	SUTO S4C-FS	107-108
Compressed Air Quality and Purity Measurement		
Oil Vapor Monitor	SUTO S120	109-112
Laser Particle Counter	SUTO S130 / S132	113-117
Portable Compressed Air Purity Analyzer	SUTO S600	118-124
Stationary Compressed Air Purity Monitor	SUTO S601	125-130
Portable Breathing Air Quality Analyzer	SUTO S605	131-136
Stationary Breathing Air Quality Analyzer	SUTO S606	137-142
Leak Management		
Ultrasonic Leak Detector (Eco Version)	SUTO S530	143-146
Smart Ultrasonic Leak Detector	SUTO S531	147-151
Leak Management System	SUTO LMS	152-154
Useful Sensors and Systems		
Power and Energy Meter	SUTO S110	155-158
Pressure Transmitter	SUTO S010 / S011	159-161
Electrical Current Transmitter	SUTO S030	162-164
Calibration and Certification		165-167
Accessories		168-172
Desiccants for Compressed Air Adsorption Dryers		
Silica Gel	AdsoMax SG B127 / SG W127	173
Activated Alumina	AdsoMax HQ-A4	174
Molecular Sieve	AdsoMax MS-4A / MS 512	175

Click me 



S401 / S421



Thermal Mass Flow Meter

Insertion / Inline



S421

S401



PROCESS MONITORING
High accuracy and reliable measurements



TOTALIZER INTEGRATED
Total consumption stored internally



S401 INSERTION METER
Installation under pressure



MOBILE APP
For remote configuration



INTEGRATED DISPLAY
For on site values



S421 IN-LINE METER
High accuracy and easy to install



Benefits

- ✓ S401 can be installed under pressure through a 1/2" ball valve
- ✓ S421 with measuring section for accurate and reliable readings
- ✓ No additional pressure or temperature compensation needed, thanks to thermal mass flow measurement
- ✓ Fast response time with a wide measuring range
- ✓ Thermal mass flow meter can be used in different process gases like: N₂, CO₂, O₂ and many other technical gases

1 Optional Color Display

On-site display for live value readings, total consumption counter and convenient sensor settings. Totalizer with 10 digits (1 999 999 999)

2 Various Outputs

S401 and S421 thermal mass flow meters are perfectly suited to be integrated into process controls or high-level monitoring systems. Various output options are offered for a seamless integration:

- Isolated 4... 20 mA output for actual flow readings
- Isolated Pulse output for totalizer
- Modbus/RTU to read all values digitally
- Modbus/TCP with PoE support to connect the meters to the local network and power them via Ethernet

3 Robust Materials

The industrial IP65 Polycarbonate-ABS housing offers the best protection in rough environments. The metal parts are made from high grade stainless steel, made to last forever.



4 Flexible and Easy Installation

- The insertion type flow meters supports any pipe size from 1" up to 12" or even bigger pipes. Thanks to the insertion through a 1/2" ball valve, the S401 can be installed under pressure and is perfectly suited for installations where shutdowns are not acceptable.
- The in-line type are offered with measuring sections from 1/2" up to 3" and can be easily integrated into existing piping systems.

5 Thermal Mass Flow Sensor

The build in sensor is using the thermal mass flow principle. This comes with main advantages:

- The sensor can cover a wide measuring range at high accuracy.
- The fast response times, no moving parts and minimal pressure loss are making them most suited sensors for volumetric flow and consumption measurement of compressed air and gases.
- There is no need to compensate the line pressure and temperature additionally, making them most efficient in terms of installations and costs.



Wireless Connection

The unique wireless connection on every flow meter is unlike its competition. Through the free S4G-FS App, live values can be read from the meters.

But not only during operation, the smartphone app is useful. Especially during installation and setup all settings can be performed using a smartphone, there is no need to carry a PC and an interface on site. This saves a lot of time and is the easiest way to get reliable sensor readings.

Every sensor is protected by default, to perform changes on the flow meter, first a QR code must be scanned.



Installation and Sensor Removal

S401

S401 can be installed under pressure through a 1/2" ball valve. The sensor tip must be in the pipes center.

- Tube diameters of DN25 and above
- 2 installation types: center installation and 100 mm insertion depth installation for bigger pipes (> DN250)
- Installation under pressure through 1/2" ball valve

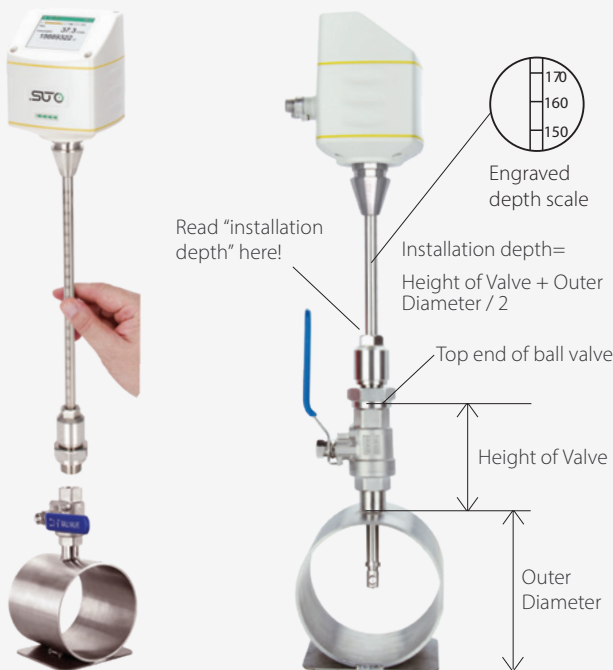

S421

The S421 sensor unit can be easily removed for calibration. (Closing cap separately available)

- Pipes sizes available: DN15, DN20, DN32, DN40, DN50, DN65, DN80
- Fits your needs: various process connections available (R-thread, EN 1092-1 flange or ANSI flange)
- Exchangeable sensor unit (easy sensor swap)
- Optional flow conditioner, no need for a straight inlet anymore





Connect several Flow Meters to Modbus Master

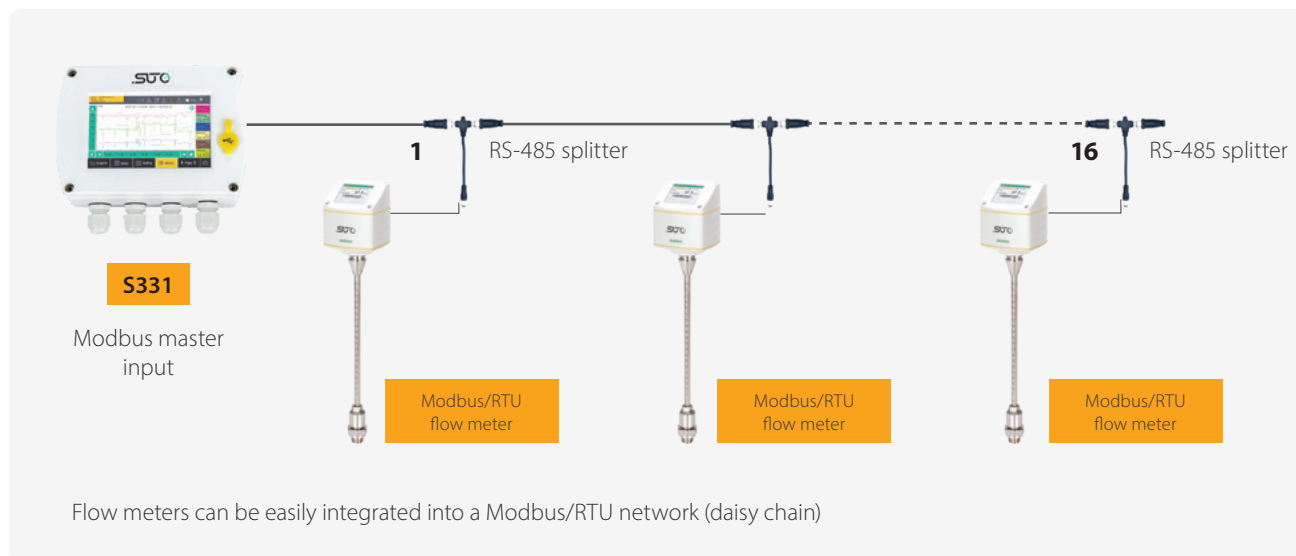

Volumetric flow ranges

Pipe Specifications			S401			S421
Inch	DN	DI (mm)	S401-S (m ³ /h)	S401-M (m ³ /h)	S401-H (m ³ /h)	Measuring range from to
½"	DN15		-	-		0.5 ... 90 m ³ /h
¾"	DN20		-	-		0.9 ... 170 m ³ /h
1"	DN25	27.3	0.5 ... 147.7	0.6 ... 294.7	0.6 ... 356.9	1.5 ... 290 m ³ /h
1¼"	DN32	36.0	0.9 ... 266.3	1.2 ... 531.5	1.2 ... 643.5	2 ... 500 m ³ /h
1½"	DN40	41.9	1.2 ... 366.7	1.5 ... 731.9	1.5 ... 886.2	3 ... 700 m ³ /h
2"	DN50	53.1	2.0 ... 600.1	2.5 ... 1197.6	3.0 ... 1450.0	4 ... 1000 m ³ /h
2½"	DN65	68.9	3.5 ... 1026.5	5.0 ... 2048.6	5.0 ... 2480.4	6 ... 1500 m ³ /h
3"	DN80	80.9	5.0 ... 1424.4	7.0 ... 2842.7	7.0 ... 3441.9	8 ... 2500 m ³ /h
4"	DN100	100.0	10 ... 2183.3	12 ... 4357.2	12.0 ... 5275.7	
5"	DN125	125.0	13 ... 3419.6	18 ... 6824.4	18.0 ... 8263.1	
6"	DN150	150.0	18 ... 4930.1	25 ... 9838.9	25.0 ... 11913.1	
8"	DN200	200.0	26 ... 8785.6	33 ... 17533.3	42.0 ... 21229.5	
10"	DN250	250.0	40 ... 13743.9	52 ... 27428.5	60.0 ... 33210.7	
12"	DN300	300.0	60 ... 19814.8	80 ... 39544.1	100.0 ... 47880.4	

Mobile Power

S401 / S421 powered by power bank with connection cable KA66A5530154.

Note: power bank must be sourced locally due to shipping restrictions [USB-C, 20 V, min. 100 mA]





S401 Dimensions

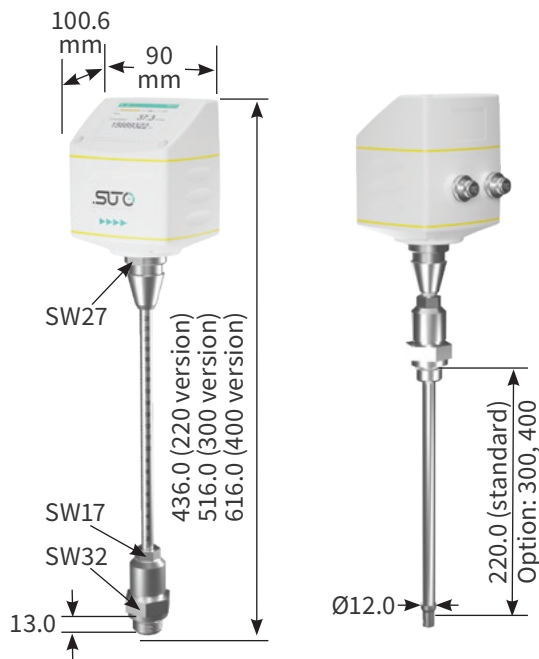

Optional Flow Conditioner

Optional flow conditioner eliminates the straight pipe inlet requirement

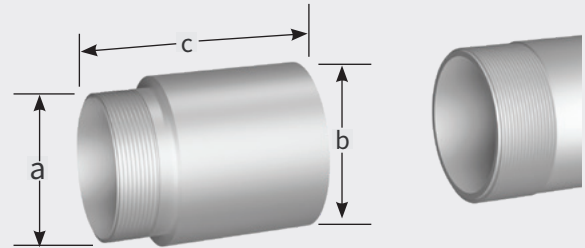

Order No.	DN	a	b in mm	c in mm
KA66000A1071	DN15	R 1/2"	24	64
KA66000A1072	DN20	R 3/4"	32	69
KA66000A1073	DN25	R 1"	37	75
KA66000A1074	DN32	R 1.25"	45	92
KA66000A1075	DN40	R 1.5"	54	92
KA66000A1076	DN50	R 2"	68	105
KA66000A1077	DN65	R 2.5"	80	128
KA66000A1078	DN80	R 3"	95	142

S421 Dimensions (Flange Type)

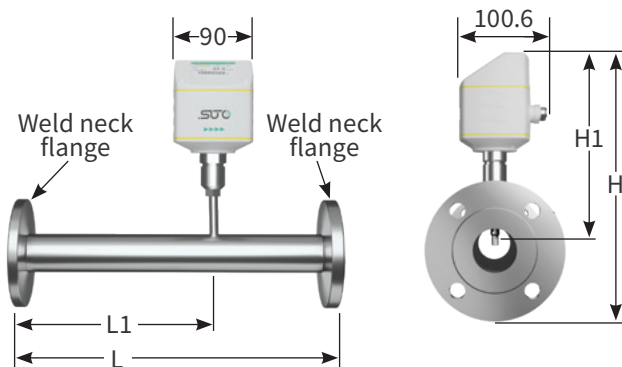

Pipe size inch / (DN)	L (mm)	L1 (mm)	H (mm)	H1 (mm)
½"(DN15)	300	210	234.2	186.7
¾"(DN20)	475	275	239.2	186.7
1"(DN25)	475	275	244.2	186.7
1¼"(DN32)	475	275	256.7	186.7
1½"(DN40)	475	275	261.7	186.7
2"(DN50)	475	275	269.2	186.7
2½"(DN65)	475	275	287.1	194.6

S421 Dimensions (Thread Type)

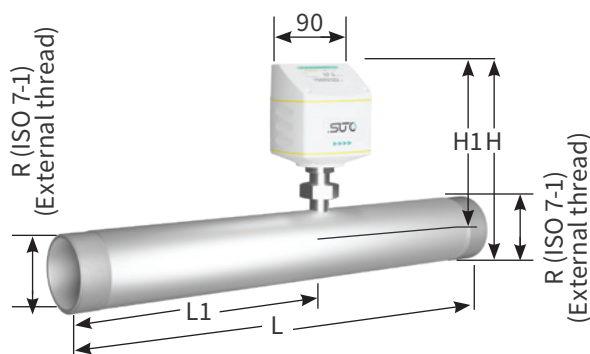

Pipe size inch / (DN)	L (mm)	L1 (mm)	H (mm)	H1 (mm)	R
½"(DN15)	300	210	197.4	186.7	R ½"
¾"(DN20)	475	275	200.2	186.7	R ¾"
1"(DN25)	475	275	203.6	186.7	R 1"
1¼"(DN32)	475	275	207.9	186.7	R 1¼"
1½"(DN40)	475	275	210.9	186.7	R 1½"
2"(DN50)	475	275	216.9	186.7	R 2"
2½"(DN65)	475	275	232.7	194.6	R 2½"
3"(DN80)	475	275	245.5	201.0	R 3"



Technical Data

Measurement

Flow

Accuracy	1.5 % of reading \pm 0.3 % FS (optional 1 % of reading)
Selectable units	m ³ /h, m ³ /min, l/min, l/s, cfm, kg/h, kg/min, kg/s
Repeatability	0.25 % of reading
Sensor	Thermal mass flow sensor
Sampling rate	10 samples / sec
Turndown ratio	1:100
Response time (t90)	0.1 sec

Consumption

Selectable units	m ³ , ft ³ , l
------------------	--------------------------------------

Reference conditions

Selectable conditions	20 °C 1000 mbar (ISO1217), 0 °C 1013 mbar (DIN1343) freely adjustable
-----------------------	---

Signal / Interface & Supply

Analog output

Signal	4 ... 20 mA (4-wire), isolated
Scaling	0 ... max flow, freely adjustable
Load	max. 250 Ohm
Update rate	Value updated ever 1 sec

Pulse output

Signal	Switch output, normally open, max. 30 VDC, 20 mA
Scaling	1 pulse per consumption unit (selectable)

Fieldbus

Protocol	Modbus/RTU, Modbus/TCP
Update rate	Value updated ever 1 sec

Supply

Voltage supply	15 ... 30 VDC
Current consumption	max. 200 mA

General data

Configuration

Wireless	S4C-FS App for mobile phones
PC Software	USB Service Kit + Software
Others	Display with 2 touch buttons

Display

Integrated	2.4" color graphic display with 2 touch buttons
------------	--

Material

Process connection	Stainless steel 1.4404 (SUS 316L)
Housing	PC + ABS
Sensor	Ceramic, glass coated
Metal parts	Stainless steel 1.4404 (SUS 316L)

Miscellaneous

Electrical connection	2 x M12 (5 pole); 1 x M12 (8-pole x-coded) for TCP
Protection class	IP65
Approvals	CE, RoHS, FCC
Process connection	S401: G1/2" (ISO 228/1) S421: Measuring section with R-thread or Flange

Weight

S401: 0.9 kg S421: 0.4 kg (without measuring section)

Operating conditions

Medium	Air, N ₂ , O ₂ , CO ₂ and other gases
Medium quality	ISO 8573: 4.4.3 or better
Medium temperature	-30 ... +140 °C
Medium humidity	< 90 % rH, no condensation
Operating pressure	max. 5.0 MPa (> 1.6 MPa need installation device)
Ambient temperature	-30 ... +70 °C, -10 ... +50 °C (with display)
Ambient humidity	< 99 % rH
Storage temperature	-30 ... +70 °C
Transport temperature	-30 ... +70 °C
Pipe sizes	S401: 1/2" ... 12" (bigger pipes on request) S421: 1/2" ... 3"



Ordering S401

Please use the following tables to assist in placing your order with our sales staff.

S401 Thermal Mass Flow Meter (Insertion type)

Article no.	Description
KA66S6954100	S401 Thermal Mass Flow Meter, 220 mm shaft
KA66S6954101	S401 Thermal Mass Flow Meter, 300 mm shaft
KA66S6954102	S401 Thermal Mass Flow Meter, 400 mm shaft
KA66S6954103	S401 Thermal Mass Flow Meter, 160 mm shaft

Flow Medium 1

KA66000A1007	Option, flow medium Air
KA66000A1008	Option, flow medium CO ₂
KA66000A1009	Option, flow medium O ₂ (cleaning for oil and grease-free)
KA66000A1010	Option, flow medium N ₂
KA66000A1011	Option, flow medium N ₂ O
KA66000A1012	Option, flow medium Argon
KA66000A1013	Option, flow medium Natural Gas
KA66000A1014	Option, flow medium H ₂ (For real gas calibration. Please consult manufacturer for this option in advance)
KA66000A1015	Other gas (specify gas or gas mix)
KA66000A1016	Option, flow medium He (real gas calibration)
KA66000A1017	Option, flow medium Propane C ₃ H ₈
KA66000A1041	Option, flow medium O ₂ , Ar, CO ₂ (real gas calibration)
KA66000A1042	Option, flow medium CH ₄ , NG, N ₂ O (real gas calibration, please consult with manufacturer for this option in advance)

Flow Medium 2 (same selection as above)

KA66000A1003 No second gas

Range

KA66000A1408	S401: Standard range version (92.7 m/s)
KA66000A1401	S401: Max range version (185 m/s)
KA66000A1402	S401: High speed range version (220 m/s)
KA66000A1403	S401/S421: Low range version (1/3 of standard range)
KA66000A1407	S401/S421: Vacuum / Atmospheric range (1/3 of standard range)

Calibration

KA66000A1409	S401/S421: Standard calibration
KA66000A1405	S401: Bi-directional calibration
KA66000A1404	S401/S421: High accuracy calibration (1 % ± 0.3 % F.S.)

Output

KA66000A1410	S401/S421: Isolated 4 ... 20 mA + pulse output
KA66000A1411	S401/S421: Modbus/RTU output
KA66000A1413	S401/S421: 4 ... 20 mA + pulse output (pin compatible to S400 / 420)
KA66000A1424	S401/S421: Modbus/TCP output with PoE support

Display

KA66000A1425	No display
KA66000A1420	S401/S421: Colorgraphic display, 2.4" with keypad

Accessories

KA66A6950008	S401: NPT½" thread adapter (former KA66000A1005)
KA66A6950009	S401: PT½" thread adapter (former KA66000A1006)
KA66A5530104	Sensor cable, 5 m with M12 connector, open wires, AWG 24 (0.2 mm ²)
KA66A5530105	Sensor cable, 10 m with M12 connector, open wires, AWG 24 (0.2 mm ²)
KA66A5530154	Cable to connect power bank, 1.8 m, USB-C connector for power bank, M12 connector

Ordering example S401:

Article no.	Description
KA66S6954100	S401 Thermal Mass Flow Meter, 220 mm shaft
KA66000A1007	Flow medium 1: Air
KA66000A1003	Flow medium 2: Without second gas
KA66000A1401	Max range version (185 m/s)
KA66000A1409	Standard calibration
KA66000A1410	Isolated 4 ... 20 mA + pulse output
KA66000A1420	Colorgraphic display, 2.4" with keypad



Ordering S421

Please use the following tables to assist in placing your order with our sales staff.

S421 Thermal Mass Flow Meter (Inline type)

Article no.	Description
KA66S6954120	S421 Thermal Mass Flow Meter (Inline), 1.6 MPa
KA66S6954121	S421 Thermal Mass Flow Meter (Inline), 4.0 MPa
Measuring section connection *	
KA66000A130X	R-thread (ISO 7-1)
KA66000A132X	Flange, EN 1092-1, PN40
KA66000A134X	Flange ANSI 16.5
Measuring section size *	
1	DN15, 1/2"
2	DN20, 3/4"
3	DN25, 1"
4	DN32, 1.25"
5	DN40, 1.5"
6	DN50, 2"
7	DN65, 2.5"
8	DN80, 3"
Flow Medium 1	
KA66000A1007	Option, flow medium Air
KA66000A1008	Option, flow medium CO ₂
KA66000A1009	Option, flow medium O ₂ (cleaning for oil and grease-free)
KA66000A1010	Option, flow medium N ₂
KA66000A1011	Option, flow medium N ₂ O
KA66000A1012	Option, flow medium Argon
KA66000A1013	Option, flow medium Natural Gas
KA66000A1014	Option, flow medium H ₂ (For real gas calibration. Please consult manufacturer for this option in advance)
KA66000A1015	Other gas (specify gas or gas mix)
KA66000A1016	Option, flow medium He (real gas calibration)
KA66000A1017	Option, flow medium Propane C ₃ H ₈
KA66000A1041	Option, flow medium O ₂ , Ar, CO ₂ (real gas calibration)
KA66000A1042	Option, flow medium CH ₄ , NG, N ₂ O (real gas calibration, please consult with manufacturer for this option in advance)
Flow Medium 2 (same selection as above)	
KA66000A1003	No second gas
Range	
KA66000A1426	S421: Standard range version
KA66000A1403	S401/S421: Low range version (1/3 of standard range)
KA66000A1407	S401/S421: Vacuum / Atmospheric range (1/3 of standard range)
Calibration	
KA66000A1409	S401/S421: Standard calibration
KA66000A1404	S401/S421: High accuracy calibration (1 % ± 0.3 % F.S.)
Output	
KA66000A1410	S401/S421: Isolated 4 ... 20 mA + pulse output
KA66000A1411	S401/S421: Modbus/RTU output
KA66000A1413	S401/S421: 4 ... 20 mA + pulse output (pin compatible to S400 / 420)
KA66000A1424	S401/S421: Modbus/TCP output with PoE support

Article no. Description

Display

KA66000A1420 S401/S421: Color graphic display, 2.4" with keypad

Flow conditioner (optional)

KA66000A107X R-thread flow conditioner (replace X with measuring section size from table in left column)

Accessories

KA66A5530104 Sensor cable, 5 m with M12 connector, open wires, AWG 24 (0.2 mm²)

KA66A5530105 Sensor cable, 10 m with M12 connector, open wires, AWG 24 (0.2 mm²)

KA66A5530154 Cable to connect power bank, 1.8 m, USB-C connector for power bank, M12 connector

Optional Flow Conditioner

Article no.	Dimensions	a	b in mm	c in mm
KA66000A1071	DN15	R 1/2"	24	64
KA66000A1072	DN20	R 3/4"	32	69
KA66000A1073	DN25	R 1"	37	75
KA66000A1074	DN32	R 1.25"	45	92
KA66000A1075	DN40	R 1.5"	54	92
KA66000A1076	DN50	R 2"	68	105
KA66000A1077	DN65	R 2.5"	80	128
KA66000A1078	DN80	R 3"	95	142

Ordering example S421:

Article no.	Description
KA66S6954120	S421 Thermal Mass Flow Meter (Inline), 1.6 MPa
KA66000A1306	R-thread (ISO 7-1), DN50 / 2"
KA66000A1008	Flow medium 1: CO ₂
KA66000A1010	Flow medium 2: N ₂
KA66000A1426	Standard range version
KA66000A1404	High accuracy calibration (1 % ± 0.3 % F.S.)
KA66000A1411	Modbus/RTU output
KA66000A1420	Color graphic display, 2.4" with keypad
KA66000A1076	R-thread flow conditioner, DN50 / 2"



www.kompauto.com



sales@kompauto.com



S415



Compact Thermal Mass Flow Meter

Eco-Inline



COMPACT DESIGN
Can be installed anywhere



SMARTPHONE ANDROID APP
For remote configuration



POINT-OF-USE MEASUREMENT
Monitor machines and air consumers



TOTAL FLOW
No bypass measurement



ACCURATE RESULTS
Integrated flow conditioner



INTEGRATED DISPLAY
For on site values



Benefits

- ✓ Compact flow meter for installation directly at the point-of use
- ✓ Various process connection sizes available: DN8, DN15, DN20, DN25 and DN32 (G-inner-thread)
- ✓ Economic flow and consumption metering at low investments
- ✓ Machine operation costs and consumption monitoring
- ✓ Integrated flow conditioner eliminates the need of straight inlet sections

Cost-efficient Eco Version – Flexible Installation

The S415 Thermal Mass Flow Meters offers compressed air flow and consumption measurement directly at the point of use with seamless integration.

These highly economical units will help you improve compressed air system efficiency, while helping reduce compressed air usage and operating costs.

The S415 come standard with wireless communication interface to help the user quickly and easily check the flow meter readings or adjust the settings via the SUTO flow meter app.

Point of Use Applications

The S415 is best suited to general process work where low cost and broad monitoring of the compressed air flow is required.

Easily monitor the compressed air flow and consumption of individual machines and processes to improve efficiency and reliability.

Various Output Signals

Output	Connector	Pin 1	Pin 2	Pin 3	Pin 4
Modbus/RTU	A	D-	-VB	+VB	D+
	B	D-	GND	NA	D+
Analog and Pulse	A	I-	-VB	+VB	I+
	B	I-	P	P	I+
M-Bus	A	M-bus	-VB	+VB	M-bus
	B	M-bus	NA	NA	M-bus
Wire colour		brown	white	blue	black

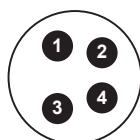

Pin assignment connector plug M8

- Every sensor includes 5m M8 cables with open ends
- Sensor with Modbus/RTU or M-Bus include 1 cable
- Sensors with Analog output include 2 cables

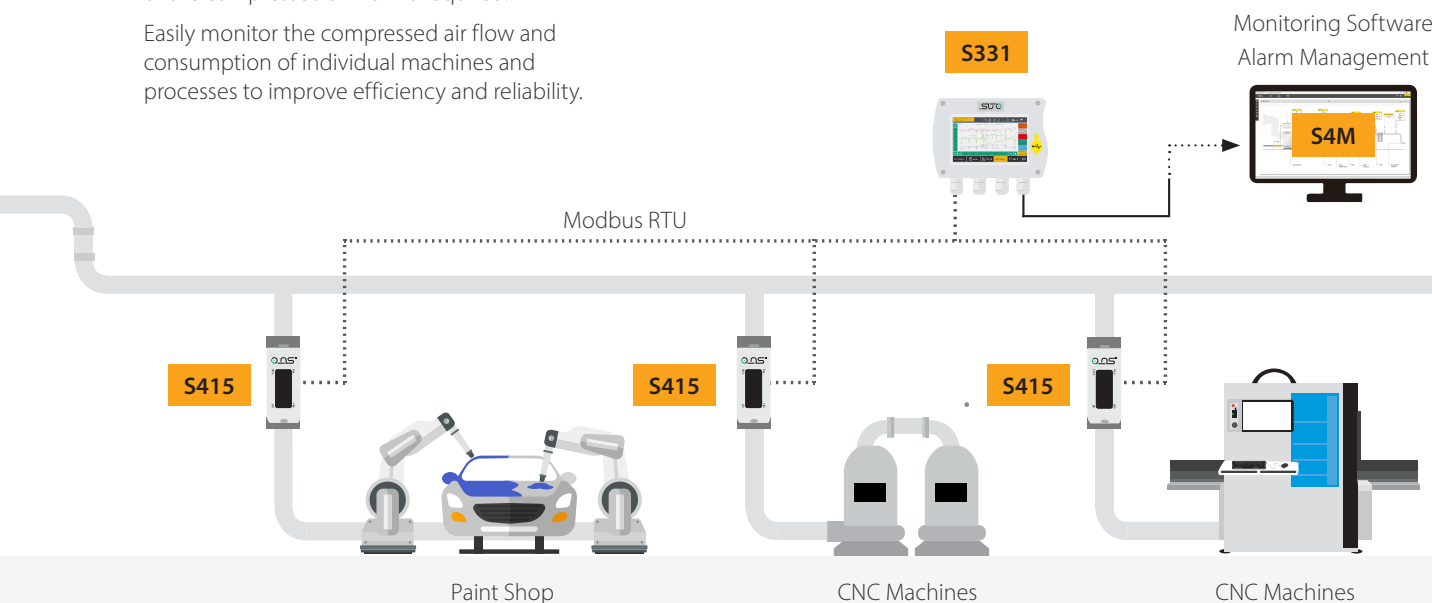



Wireless Connection

The free S4C-FS App offers a unique wireless connection to every SUTO flow meter for online readings and configuration.

Especially during installation and setup all settings can be performed using a smartphone, there is no need to carry a PC and an interface on site. This saves a lot of time and is the easy way to get reliable sensor readings.

Every sensor is protected by default. To perform changes on the flow meter, first a QR code must be scanned.

Flow Conditioner

Asymmetric velocity profiles, swirl, and other factors caused by bends in pipes can lead quickly to inaccurate readings. But sometimes there is not enough space to have straight inlet conditions for accurate readings.

The highly engineered flow conditioner solves this problem. Unlike a standard flow conditions disk, the 3D design of the flow conditioner allows measurements with no additional straight inlet piping at all. Thanks to the innovative mechanical design, the pressure loss is negligible small (<30 hPa), offering high accurate measurements in difficult pipe conditions.

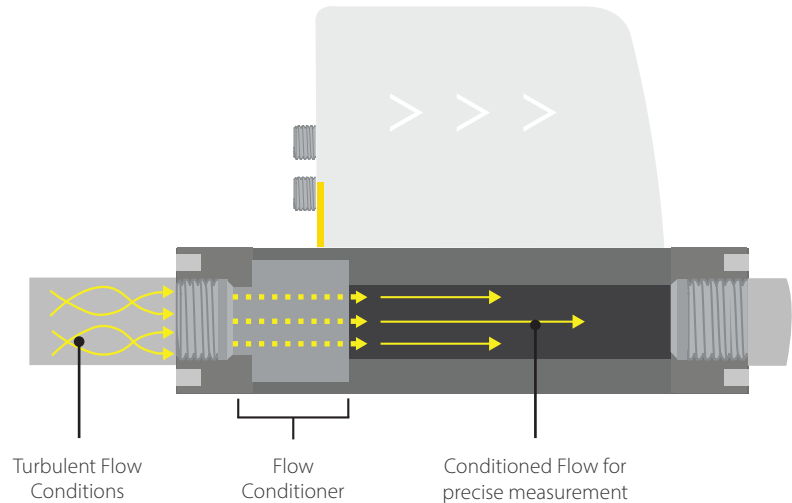

Connect several S415 to Modbus Master

The S415 with Modbus/RTU interface can be easily daisy-chained to a Modbus Master device such as S331 by using RS-485 splitter (KA66A5543310) and the M8 to M12 converter cable (KA66A5530161). Through this method you can add up to 16 flow meters to the master device

Remark: The S331 can maximum provide 10 W power to the connected devices. If more power is required a separate power supply is needed..

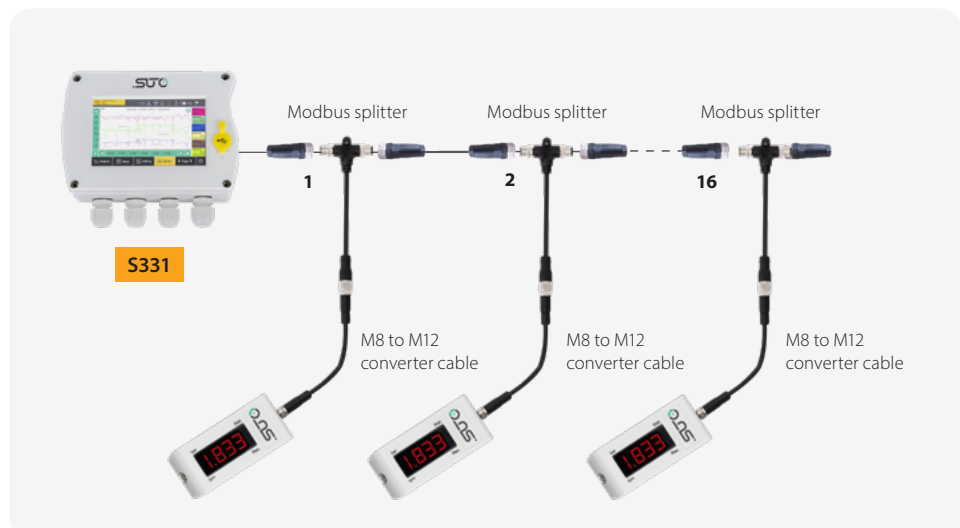



Display Direction

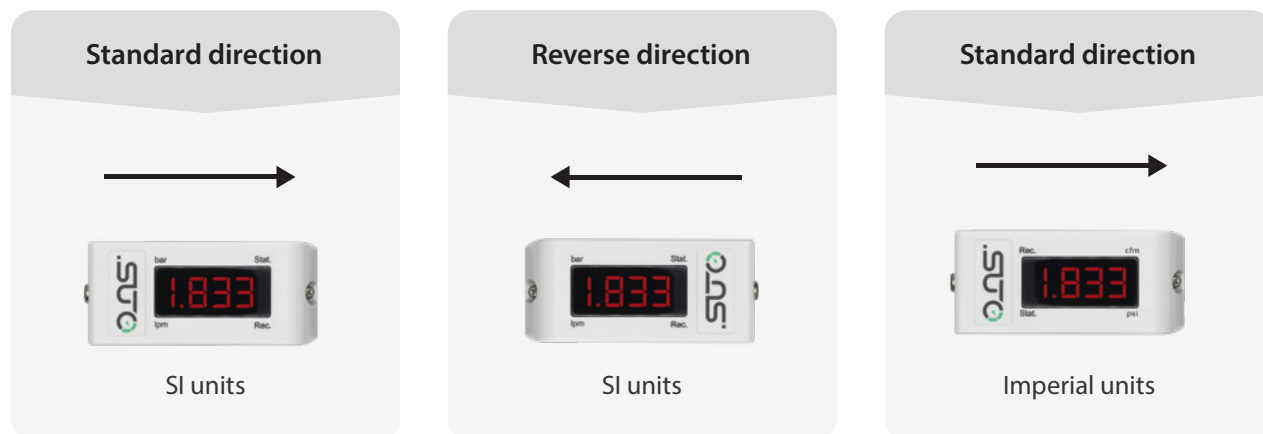

Measuring Range in Air (l/min)

Range	Standard Configuration				
Process connection	DN8	DN15	DN20	DN25	DN32
Standard range (S)	250	1000	2000	3500	6000
Low range (L)	50	200	400	700	1200

Stated measuring ranges for S415 under following conditions:

- Standard flow in air in l/min
- Reference pressure: 1000 mbar
- Reference Temperature: +20 °C

Measuring ranges in Nitrogen are different. Please contact us for details at sales@kompauto.com



Dimensions

Dimensions in mm	a	b	c	d	e
DN8/DN15	35.0	93.0	120.4	35.0	48.0
DN20/DN25	48.0	106.0	178.0	48.0	61.0
DN32	60.0	118.0	222.0	60.0	73.0

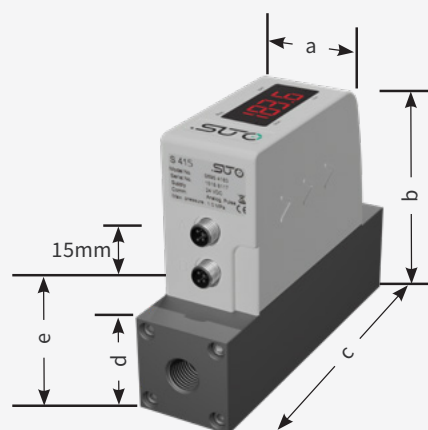



Technical Data

Measurement

Flow

Accuracy	3 % o.RDG \pm 0.3 % FS
Selectable units	l/min, cfm, kg/h, m ³ /h
Measuring range	see table on the previous page
Repeatability	1 % o.RDG
Sensor	Thermal mass flow sensor
Sampling rate	3/sec
Turndown ratio	50:1
Response time (t90)	2 sec

Consumption

Selectable units	m ³ , ft ³ , l, kg
------------------	--

Reference conditions

Selectable conditions	20 °C 1000 mbar (ISO1217) 0 °C 1013 mbar (DIN1343) freely adjustable
-----------------------	--

Signal / Interface & Supply

Analog output

Signal	4 ... 20 mA, isolated
Scaling	0 ... max flow
Load	250R
Update rate	3/sec

Pulse output

Signal	Max 30 V, 200 mA
Scaling	1 pulse per consumption unit

Fieldbus

Interface/Protocol	RS-485/Modbus/RTU M-Bus
--------------------	----------------------------

Supply

Voltage supply	15 ... 30 VDC
Current consumption	120 mA @ 24 VDC

General data

Configuration

Wireless	S4C-FS App for mobile phones
----------	------------------------------

Display

Integrated	4 digit LED
------------	-------------

Material

Process connection	Aluminum alloy
Housing	PC + ABS
Sensor	Glass coated resistive sensor
Metal parts	Aluminum alloy

Miscellaneous

Electrical connection	2 x M8 (4 pole)
Protection class	IP54
Approvals	CE, RoHS, FCC
Process connection	G-thread
Weight	0.45 ... 1.3 kg (depends on model)

Operating conditions

Medium	Air, N ₂
Medium quality	ISO 8573: 4.4.3 or better
Medium temperature	0 ... 50 °C
Medium humidity	< 90 % rH, no condensation
Operating pressure	0 ... 10 bar(g)
Ambient temperature	0 ... 50 °C
Ambient humidity	< 95 % rH
Storage temperature	-30 ... 70 °C
Transport temperature	-30 ... 70 °C
Pipe sizes	DN8, DN15, DN20, DN25, DN32



Ordering

Please use the following tables to assist in placing your order with our sales staff.

S415 Compact Thermal Mass Flow Meter (Inline)

Order No.	Description
KA66S695415X	S415 Compact Thermal Mass Flow Meter, G inner thread, 24 VDC, 5 m cable with M8 connector and open ends included (replace X in order no. with size code in table below)
Size	
0	DN8
1	DN15
2	DN20
3	DN25
4	DN32
Range	
KA66000A1464	Standard range version
KA66000A1453	Low range version
Output	
KA66000A1450	Analog 4 ... 20 mA, Pulse Output
KA66000A1451	Modbus/RTU output
KA66000A1452	M-Bus output
Gas type	
KA66000A1007	Air
KA66000A1010	N ₂
Units	
KA66000A1466	With SI Units
KA66000A1458	With imperial units
Display direction	
KA66000A1462	Standard display direction (left to right)
KA66000A1460	Reverse display direction
Example:	S415 DN8, Modbus/RTU, Air, imperial units and a mains power supply as accessory
Order Codes:	KA66S6954150 KA66000A1451 KA66000A1007 KA66000A1458 KA66A5540109

S415 Accessories

Order No.	Description
KA66A5540109	Mains power supply 100-240 VAC / 24 VDC, 0.5 A, 2 m cable with M8 connector
KA66A5530137	Connection cable to S551, 5 m
KA66A5530161	M8 to M12 converter cable for Modbus splitter
KA66A5530171	Cable to connect power bank, 1.8 m, USB-C connector for power bank, M8 connector
KA66A5543310	RS-485 / Modbus splitter

Mobile Power

S415 powered by power bank with connection cable KA66A5530171

Note: power bank must be sourced locally due to shipping restrictions [USB-C, 20 V, min. 100 mA]



www.kompauto.com



sales@kompauto.com



S418



Compact Thermal Mass Flow Meter

Pro-Inline



SMARTPHONE ANDROID APP
For remote configuration



POINT-OF-USE MEASUREMENT
Monitor machines and air consumers



COMPACT DESIGN
Can be installed anywhere



TOTAL FLOW
No bypass measurement



EASY PROCESS MONITORING
Effective and inexpensive recording



ACCURATE RESULTS
Integrated flow conditioner



Benefits

- ✓ Highly versatile flow and consumption meter for compressed air and technical gases
- ✓ Integrated pressure sensor optional
- ✓ Integrated data logger for measurement recordings as standard feature
- ✓ Various process connection sizes available: DN8, DN15, DN20, DN25 and DN32 (G-inner-thread)
- ✓ Accurate monitoring of gas supplies and consumers
- ✓ Integrated flow conditioner eliminates the need of straight inlet sections

Powerful Pro Version – Flexible Installation

The S418 Thermal Mass Flow Meters offers compressed air flow and gas measurement directly at the point of use.

It comes standard with wireless communication interface to help the user quickly and easily check the flow meter readings or adjust the settings via the SUTO flow meter app.

Improve your compressed air system efficiency, while helping reduce compressed air and gas usage and operating costs by monitoring:

- Flow and Consumption
- Pressure
- Temperature

Connection

Pin assignment connector plug M8

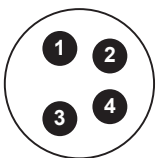

- Every sensor includes 5m M8 cables with open ends
- Sensor with Modbus/RTU or M-Bus include 1 cable
- Sensors with Analog output include 2 cables

Output	Connector	Pin 1	Pin 2	Pin 3	Pin 4
Modbus/RTU	A	D-	-VB	+VB	D+
	B	D-	GND	NA	D+
Analog and Pulse	A	I-	-VB	+VB	I+
	B	I-	P	P	I+
M-Bus	A	M-bus	-VB	+VB	M-bus
	B	M-bus	NA	NA	M-bus
Wire colour		brown	white	blue	black

Gas Monitoring Application

The S418 is ideal for remote locations or high accuracy compressed air flow and gas measurements with its built-in data logger and optional pressure sensing.

The compact flow meters provide accurate gas flow monitoring, helping to discover weak points in the process flow, thus ensuring continuity and profitability.

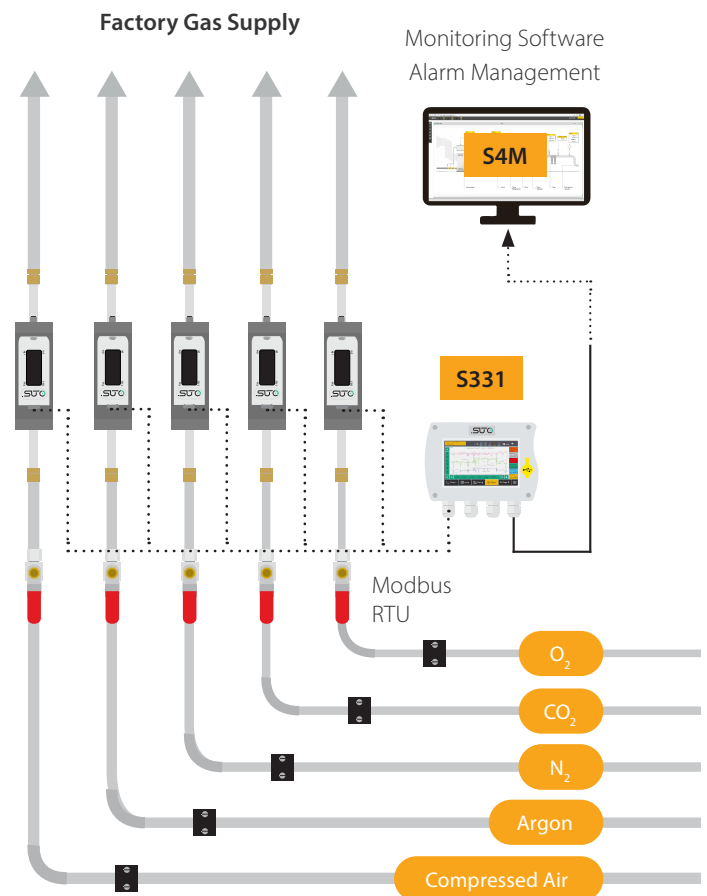



Wireless Connection

The free S4C-FS App offers a unique wireless connection to every SUTO flow meter for online readings and configuration.

Especially during installation and setup all settings can be performed using a smartphone, there is no need to carry a PC and an interface on site. This saves a lot of time and is the easy way to get reliable sensor readings.

Every sensor is protected by default. To perform changes on the flow meter, first a QR code must be scanned.



Flow Conditioner

Asymmetric velocity profiles, swirl, and other factors caused by bends in pipes can lead quickly to inaccurate readings. But sometimes there is not enough space to have straight inlet conditions for accurate readings.

The highly engineered flow conditioner solves this problem. Unlike a standard flow conditions disk, the 3D design of the flow conditioner allows measurements with no additional straight inlet piping at all. Thanks to the innovative mechanical design, the pressure loss is negligible small (<30 hPa), offering high accurate measurements in difficult pipe conditions.

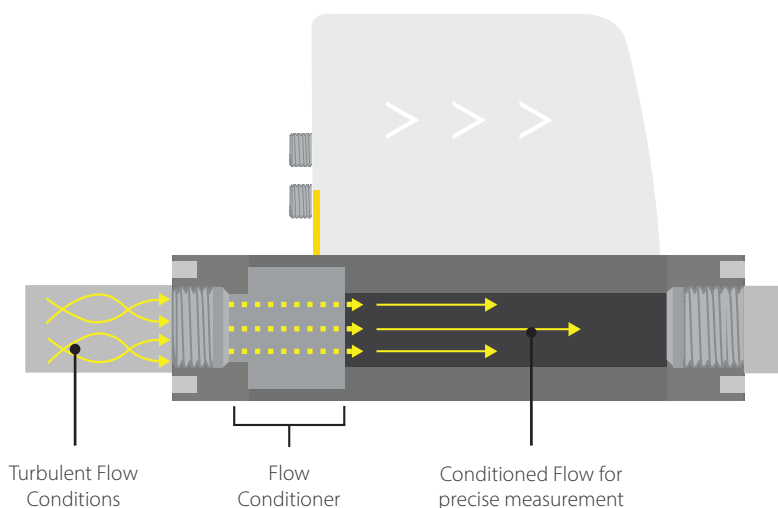

Connect several S418 to Modbus Master

The S418 with Modbus/RTU interface can be easily daisy-chained to a Modbus Master device such as S331 by using RS-485 splitter (KA66A5543310) and the M8 to M12 converter cable (KA66A5530161). Through this method you can add up to 16 flow meters to the master.

Remark: The S331 can maximum provide 10 W power to the connected devices. If more power is required a separate power supply is needed.

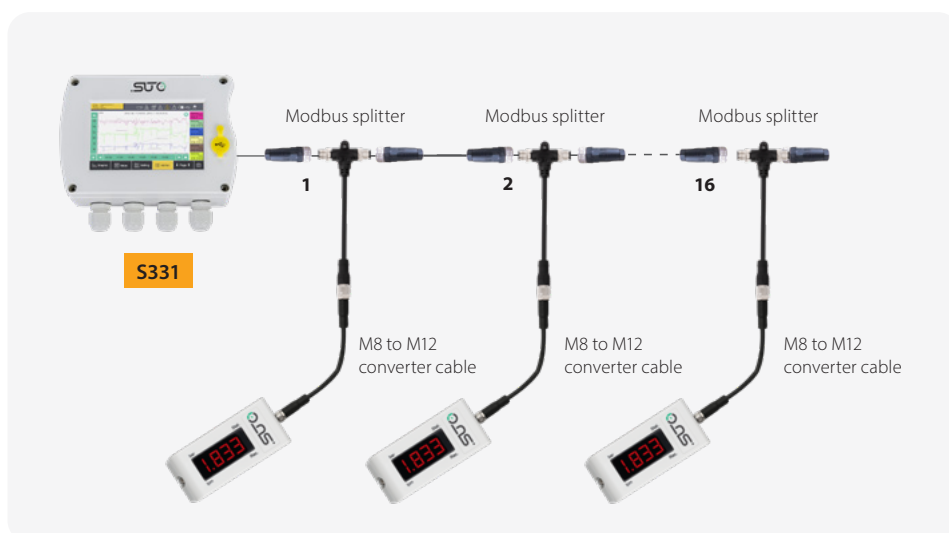

Display Direction

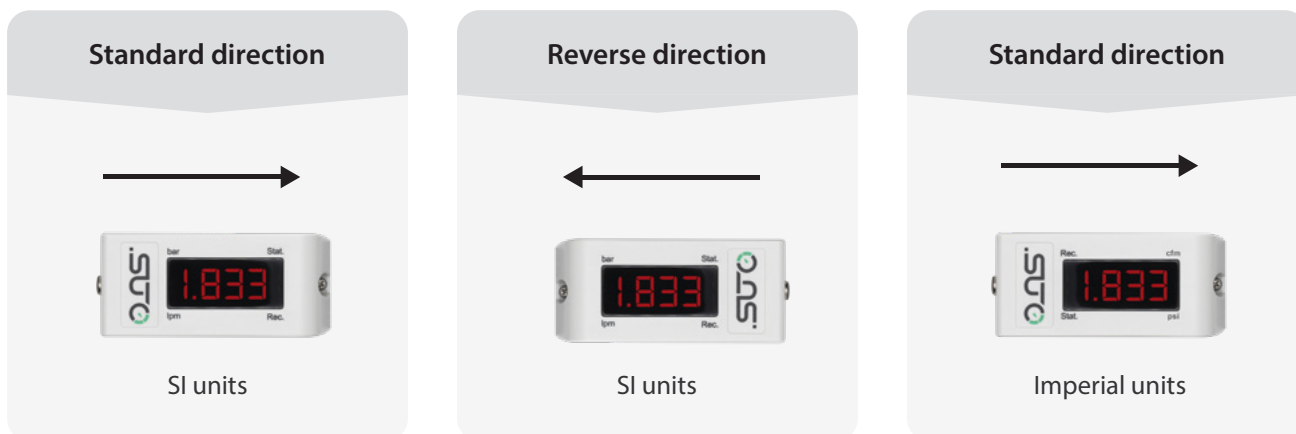

Measuring Range in Air (l/min)

Range	Standard Configuration				
Process connection	DN8	DN15	DN20	DN25	DN32
Standard range (S)	250	1000	2000	3500	6000
Low range (L)	50	200	400	700	1200

Stated measuring ranges for S418 under following conditions:

- Standard flow in air in l/min
- Reference pressure: 1000 mbar
- Reference Temperature: +20 °C

Measuring ranges in Nitrogen are different. Please contact us for details at sales@kompauto.com



Dimensions

Dimensions in mm	a	b	c	d	e
DN8/DN15	35.0	93.0	120.4	35.0	48.0
DN20/DN25	48.0	106.0	178.0	48.0	61.0
DN32	60.0	118.0	222.0	60.0	73.0

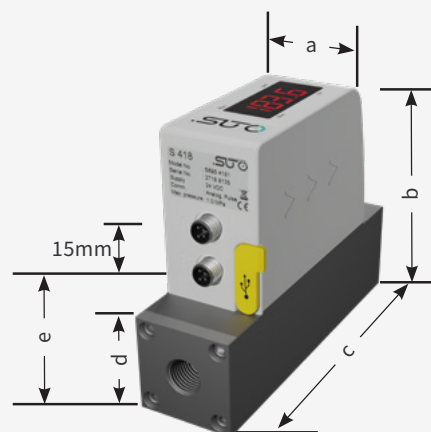



Technical Data

Measurement

Flow

Accuracy	1.5 % o.RDG \pm 0.3 % FS
Selectable units	l/min, cfm, kg/h, m ³ /h
Measuring range	see table on the previous page
Repeatability	0.5 % o.RDG
Sensor	Thermal mass flow sensor
Sampling rate	10/sec
Turndown ratio	100:1
Response time (t90)	0.5 sec

Consumption

Selectable units	m ³ , ft ³ , l, kg
------------------	--

Pressure

Accuracy	0.5 % FS
Selectable units	bar, psi
Measuring range	0 ... 10 bar(g)
Sensor	Piezoresistive sensor

Reference conditions

Selectable conditions	20 °C 1000 mbar (ISO1217), 0 °C 1013 mbar (DIN1343) freely adjustable
-----------------------	---

Signal / Interface & Supply

Analog output

Signal	4 ... 20 mA (4-wire), isolated
Scaling	0 ... max flow
Load	Max 250 Ω freely adjustable
Update rate	3/sec

Pulse output

Signal	Switch output, normally open, max 30 VDC, 200 mA
Scaling	1 pulse per consumption unit

Fieldbus

Protocol	Modbus/RTU
----------	------------

Supply

Voltage supply	15 ... 30 VDC
Current consumption	120 mA @ 24 VDC

Data interface

Connection	USB micro
------------	-----------

General data

Configuration

Wireless	S4C-FS App for mobile phones
PC Software	S4A PC software for download and data analyzes

Display

Integrated	4 digit LED
------------	-------------

Data Logger

Storage	8 Mio. values
---------	---------------

Material

Process connection	Aluminum alloy
Housing	PC + ABS
Sensor	Ceramic, glass coated
Metal parts	Aluminum alloy

Miscellaneous

Electrical connection	2 x M8 (4 pole)
Protection class	IP54
Approvals	CE, RoHS, FCC
Process connection	G-thread
Weight	0.45 ... 1.3 kg (depends on model)

Operating conditions

Medium	Air, N ₂ , O ₂ , CO ₂ and other gases
Medium quality	ISO 8573: 4.4.3 or better
Medium temperature	0 ... 50 °C
Medium humidity	< 90 % rH, no condensation
Operating pressure	0 ... 10 bar(g)
Ambient temperature	0 ... 50 °C
Ambient humidity	< 95 % rH
Storage temperature	-30 ... 70 °C
Transport temperature	-30 ... 70 °C
Pipe sizes	DN8, DN15, DN20, DN25, DN32



Ordering

Please use the following tables to assist in placing your order with our sales staff.

S418 Compact Thermal Mass Flow Meter (Pro-Inline)

Order No.	Description
KA66S695418X	S418 Compact Thermal Mass Flow Meter with integrated data logger, G inner thread, 24 VDC, 5 m cable with M8 connector and open ends included (replace X in order no. with size code in table below)

Size + Pressure sensor option

KA66S6954180	DN8
KA66S6954181	DN15
KA66S6954182	DN20
KA66S6954183	DN25
KA66S6954184	DN32
KA66S6954185	DN8, Pressure sensor 10 bar(g)
KA66S6954186	DN15, Pressure sensor 10 bar(g)
KA66S6954187	DN20, Pressure sensor 10 bar(g)
KA66S6954188	DN25, Pressure sensor 10 bar(g)
KA66S6954189	DN32, Pressure sensor 10 bar(g)

Range

KA66000A1465	Standard range version
KA66000A1453	Low range version

Output

KA66000A1455	S418: Analog 4 ... 20 mA, Pulse output
KA66000A1456	S418: Modbus/RTU output
KA66000A1457	S418: M-Bus output

Fluid Medium 1

KA66000A1007	Air
KA66000A1008	CO ₂
KA66000A1009	O ₂ (Oil- & grease-free cleaned)
KA66000A1010	N ₂
KA66000A1011	N ₂ O
KA66000A1012	Argon
KA66000A1013	Natural Gas
KA66000A1014	H ₂ (Real gas calibration)
KA66000A1015	Other Gas (Please specify)
KA66000A1016	He (Real gas calibration)
KA66000A1017	C ₃ H ₈

Fluid Medium 2 (same selections as above)

KA66000A1003	No second gas
--------------	---------------

Units

KA66000A1467	With SI units
KA66000A1459	With imperial units

Display direction

KA66000A1463	Standard display direction (left to right)
KA66000A1461	Reverse display direction

Example: S418 DN25, Modbus/RTU, CO₂, imperial units

Order Codes: KA66S6954183

KA66000A1456

KA66000A1008

KA66000A1459

S418 Accessories

Order No.	Description
KA66A5540109	Mains power supply 100-240 VAC / 24 VDC, 0.5 A, 2 m cable with M8 connector
KA66A5530137	Connection cable to S551, 5 m
KA66M5997020	S4A data analysis software, for data logger S418
KA66A5530161	M8 to M12 converter cable for Modbus splitter
KA66A5530171	Cable to connect power bank, 1.8 m, USB-C connector for power bank, M8 connector
KA66A5543310	RS-485 / Modbus splitter

Mobile Power

S418 powered by power bank with connection cable KA66A5530171

Note: power bank must be sourced locally due to shipping restrictions [USB-C, 20 V, min. 100 mA]



www.kompauto.com



sales@kompauto.com



S418-V



Compact Thermal Mass Flow Meter for Vacuum Applications

Pro-Inline



SMARTPHONE ANDROID APP

For remote configuration



POINT-OF-USE MEASUREMENT

Monitoring of vacuum pumps



COMPACT DESIGN

Can be installed anywhere



TOTAL FLOW

No bypass measurement



EASY PROCESS MONITORING

Effective and inexpensive recording



ACCURATE RESULTS

Integrated flow conditioner



Benefits

- ✔ Highly economical point-of-use flow and consumption measurements at the low pressure side of vacuum pumps
- ✔ Integrated data logger for measurement recordings as standard feature
- ✔ Various process connection sizes available: DN8, DN15, DN20 and DN25 (G-inner-thread)
- ✔ Absolute pressure sensor integrated for actual vacuum flow measurements
- ✔ Integrated flow conditioner eliminates the need of straight inlet sections
- ✔ Optional integrated pressure sensor

Optimize Your Vacuum System Efficiency

The S418-V Compact Thermal Mass Flow Meter offers a simple but effective monitoring solution for vacuum applications at the point-of use.

It comes standard with wireless communication interface to help the user quickly and easily check the flow meter readings or adjust the settings via the SUTO flow meter app.

Improve your vacuum system efficiency, while helping to reduce operating costs by monitoring:

- Flow and Consumption
- Pressure
- Temperature

Various Output Signals

Output	Connector	Pin 1	Pin 2	Pin 3	Pin 4
Modbus/RTU	A	D-	-VB	+VB	D+
	B	D-	GND	NA	D+
Analog and Pulse	A	I-	-VB	+VB	I+
	B	I-	P	P	I+
M-Bus	A	M-bus	-VB	+VB	M-bus
	B	M-bus	NA	NA	M-bus
Wire colour		brown	white	blue	black

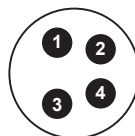

Pin assignment connector plug M8

- Every sensor includes 5m M8 cables with open ends
- Sensor with Modbus/RTU or M-Bus include 1 cable
- Sensors with Analog output include 2 cables

Vacuum Applications

S418-V is used for performance monitoring of vacuum pumps. Equipped with an absolute pressure sensor, it does not only show the vacuum pressure, but also shows the actual vacuum flow. These parameters are most the critical values in vacuum applications and help operators to ensure their process reliability.

Monitoring Software Alarm Management

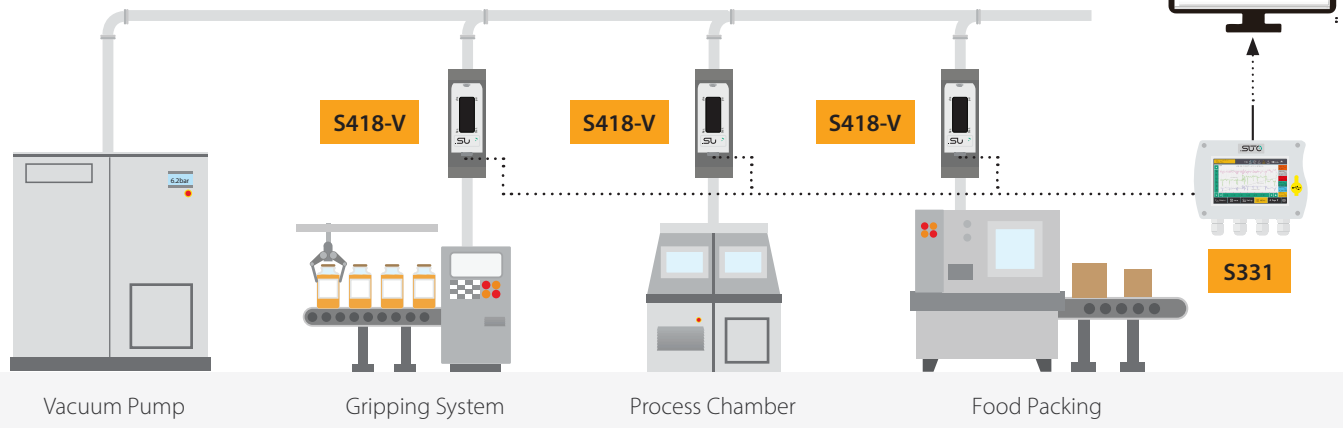



Wireless Connection

The free S4C-FS App offers a unique wireless connection to every SUTO flow meter for online readings and configuration.

Especially during installation and setup all settings can be performed using a smartphone, there is no need to carry a PC and an interface on site. This saves a lot of time and is the easy way to get reliable sensor readings.

Every sensor is protected by default. To perform changes on the flow meter, first a QR code must be scanned.

Flow Conditioner

Asymmetric velocity profiles, swirl, and other factors caused by bends in pipes can lead quickly to inaccurate readings. But sometimes there is not enough space to have straight inlet conditions for accurate readings.

The highly engineered flow conditioner solves this problem. Unlike a standard flow conditions disk, the 3D design of the flow conditioner allows measurements with no additional straight inlet piping at all. Thanks to the innovative mechanical design, the pressure loss is negligible small (<30 hPa), offering high accurate measurements in difficult pipe conditions.

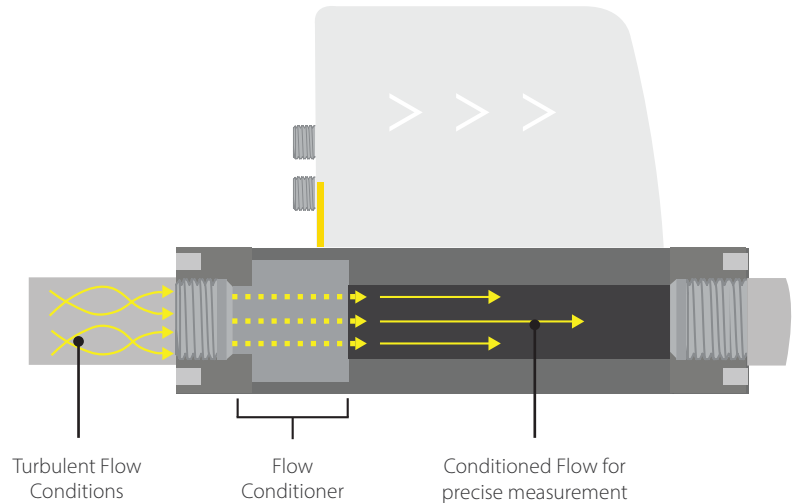

Connect several S418-V to Modbus Master

The S418-V with Modbus/RTU interface can be easily daisy-chained to a Modbus Master device such as S331 by using RS-485 splitter (KA66A5543310) and the M8 to M12 converter cable (KA66A5530161). Through this method you can add up to 16 flow meters to the master

Remark: The S331 can maximum provide 10 W power to the connected devices. If more power is required a separate power supply is needed..

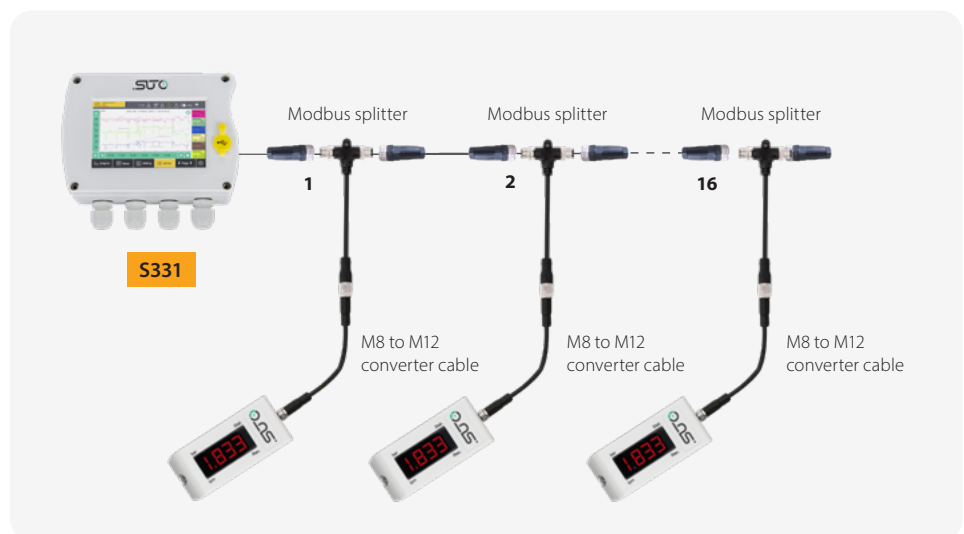



Display Direction



Measuring Range in Air (l/min)

Range	Standard Configuration				Absolute Pressure (mbar)
Process connection	DN8	DN15	DN20	DN25	
Vacuum flow in l/min	56	222	444	778	900
	63	250	500	875	800
	71	286	571	1000	700
	83	333	667	1167	600
	100	400	800	1400	500
	125	500	1000	1750	400
	167	557	1333	2333	300
	250	1000	2000	3500	200
	500	2000	4000	7000	100

Stated measuring ranges for S418-V under following conditions:

- Standard flow in air in l/min
- Reference pressure: 1000 mbar
- Reference Temperature: +20 °C



Dimensions

Dimensions in mm	a	b	c	d	e
DN8/DN15	35.0	93.0	120.4	35.0	48.0
DN20/DN25	48.0	106.0	178.0	48.0	61.0

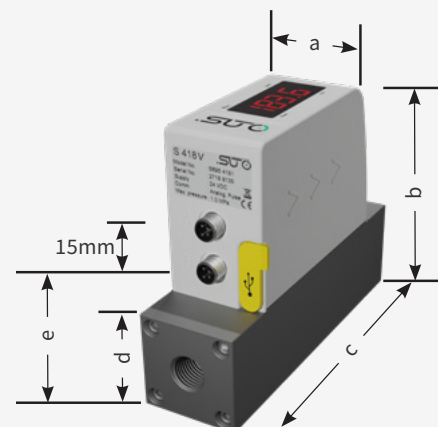



Technical Data

Measurement

Flow

Accuracy	1.5 % of reading \pm 0.3 % FS
Selectable units	m ³ /h, l/min, cfm, kg/h
Measuring range	see table on the previous page
Repeatability	0.5 % of reading
Sensor	Thermal mass flow sensor
Sampling rate	10 samples / sec
Turndown ratio	1:100
Response time (t90)	0.5 sec

Consumption

Selectable units	m ³ , ft ³ , l, kg
------------------	--

Pressure

Accuracy	0.5 % FS
Selectable units	bar, psi
Measuring range	0.01 ... 1.6 bar(a)
Sensor	Piezo resistive sensor

Reference conditions

Selectable conditions	20 °C 1000 mbar (ISO1217)
-----------------------	---------------------------

Signal / Interface & Supply

Analog output

Signal	4 ... 20 mA (4-wire), isolated
Scaling	0 ... max flow, freely adjustable
Load	max. 250 Ohm
Update rate	3/sec

Pulse output

Signal	Switch output, normally open, max. 30 VDC, 200 mA
Scaling	1 pulse per consumption unit

Fieldbus

Protocol	Modbus/RTU
----------	------------

Supply

Voltage supply	15 ... 30 VDC
Current consumption	120 mA @ 24 VDC

Data interface

Connection	USB micro
------------	-----------

General data

Configuration

Wireless	S4C-FS App for mobile phones
PC Software	S4A PC software for data analyzes

Display

Integrated	4 digit LED
------------	-------------

Data Logger

Storage	8 Mio. values
---------	---------------

Material

Process connection	Aluminum alloy
Housing	PC + ABS
Sensor	Ceramic, glass coated
Metal parts	Aluminum alloy

Miscellaneous

Electrical connection	2 x M8 (4 pole)
Protection class	IP54
Approvals	CE, RoHS, FCC
Process connection	G-thread
Weight	0.45 ... 1.1 kg (depends on model)

Operating conditions

Medium	Air, N ₂ , O ₂ , CO ₂ and other gases
Medium quality	ISO 8573: 4.4.3 or better
Medium temperature	0 ... 50 °C
Medium humidity	< 90 % rH, no condensation
Operating pressure	Max. 10 bar(g)
Ambient temperature	0 ... 50 °C
Ambient humidity	< 95 % rH
Storage temperature	-30 ... 70 °C
Transport temperature	-30 ... 70 °C
Pipe sizes	DN8, DN15, DN20, DN25

Vacuum Scales

bar(a)	inch Hg(g)	kPa(g)	bar(g)	mbar(a)
1.00	0.00	0	0.00	1000
0.90	-2.95	-10	-0.10	900
0.80	-5.91	-20	-0.20	800
0.70	-8.86	-30	-0.30	700
0.60	-11.81	-40	-0.40	600
0.50	-14.77	-50	-0.50	500
0.40	-17.72	-60	-0.60	400
0.30	-20.67	-70	-0.70	300
0.20	-23.63	-80	-0.80	200
0.10	-26.58	-90	-0.90	100
0.01	-29.24	-99	-0.99	10



Ordering

Please use the following tables to assist in placing your order with our sales staff.

S418-V Compact Thermal Mass Flow Meter for Vacuum Applications (Inline)

Order No.	Description
KA66S695419X	S418-V, Vacuum Flow Meter with integrated absolute pressure sensor, G inner thread, 24 VDC, 5 m cable with M8 connector and open ends included (replace X in order no. with size code in table below)

Size

KA66S6954190	DN8
KA66S6954191	DN15
KA66S6954192	DN20
KA66S6954193	DN25

Output

KA66000A1455	S418: Analog 4 ... 20 mA, Pulse output
KA66000A1456	S418: Modbus/RTU output
KA66000A1457	S418: M-Bus output

Units

KA66000A1459	With imperial units
--------------	---------------------

Display direction

KA66000A1463	Standard display direction (left to right)
KA66000A1461	Reverse display direction

Example: S418-V DN25, Modbus/RTU

Order Codes: KA66S6954193

KA66000A1456

S418-V Accessories

Order No.	Description
KA66A5540109	Mains power supply 100-240 VAC / 24 VDC, 0.5 A, 2 m cable with M8 connector
KA66A5530137	Connection cable to S551, 5 m
KA66M5997020	S4A data analysis software, for data logger S418-V
KA66A5543310	RS-485 / Modbus splitter
KA66A5530161	M8 to M12 converter cable for Modbus splitter
KA66A5530171	Cable to connect power bank, 1.8 m, USB-C connector for power bank, M8 connector

Mobile Power

S418-V powered by power bank with connection cable
KA66A5530171

Note: power bank must be sourced locally due to shipping restrictions [USB-C, 20 V, min. 100 mA]





S451 / S453



Thermal Mass Flow Meter for Heavy Duty and Ex Applications

Insertion / In-line



S453

S451



INDUSTRIAL DESIGN
For outdoor applications



WIRELESS INTERFACE
User friendly sensor settings



NO MECHANICAL WEAR PARTS
Long term stability



EXPLOSION PROOF
Use in Ex-area applications



EASY TO CLEAN WETTED PARTS
Stainless steel or nickel plated metal



ACCURATE MEASUREMENT
Digital control loop and data processing



Benefits

- ✓ Accurate thermal mass flow measurements and directly measure mass flow, standard flow, consumption, pressure and temperature with the integrated pressure sensor
- ✓ Rugged metal housing designed for harsh outdoor environments
- ✓ Easy access to measurement data via the integrated data logger using the free S4C-FS smartphone app
- ✓ All components in contact with the medium are made of stainless steel or nickel-plated metal
- ✓ Mechanical design with no moving parts for clog-free operation
- ✓ Budget-friendly maintenance through consistent, rugged and reliable measurements

1 Robust Materials

- The IP67 housing allows applications in harsh industrial environment as well as outdoor applications.
- All parts which come into contact with the measurement medium are made of stainless steel or nickel-plated metal. This makes the sensors robust and guarantees a reliable measurement.

2 Color Display

- The display shows all relevant measurement values on site. This allows the user to verify readings easy and quickly during installation and use.
- The pressure-tight encapsulation protects the display from external influences and ensures that it is always clearly visible.
- 3 optical buttons allow configuration at sites where mobile phones are not allowed

3 Flexible and easy Installation

- The S451 and S453 can be used in a wide range of pipe sizes. Insertion type sensor for bigger pipe diameters and the in-line type for smaller pipes.
- Smartphone app for Android and iOS enables convenient and wireless configuration, online readings and logger data download.

4 Outputs and Data Logger

- Modbus/RTU & 2 x 4 ... 0 mA + Puls/Alarm output
- Modbus/TCP over Ethernet/APL & 2 x 4 ... 20 mA + Puls/Alarm output
- Integrated data logger to record and store measurement data





Integrated Data Logger

Experience operational excellence with our advanced thermal mass flowmeter integrated with a data logger. Seamlessly monitor real-time flow rates, temperatures and pressures for informed decision making. This logger is designed to efficiently collect and store measurement data to provide unparalleled insight into your processes and compressed air system.

Data can be easily downloaded wirelessly to your smartphone using the free S4C-FS app.



Installation

S451

Insertion type sensor for installations under pressure through ball valve



S453

In-line type with measuring section.
Process connection through flanges or R-thread



Rotation

Achieve effortless customization during installation by effortlessly rotating the sensor head 180°. This simple adjustment ensures optimum visibility of the display exactly where it is needed, requiring only the removal of 4 screws from the main body.

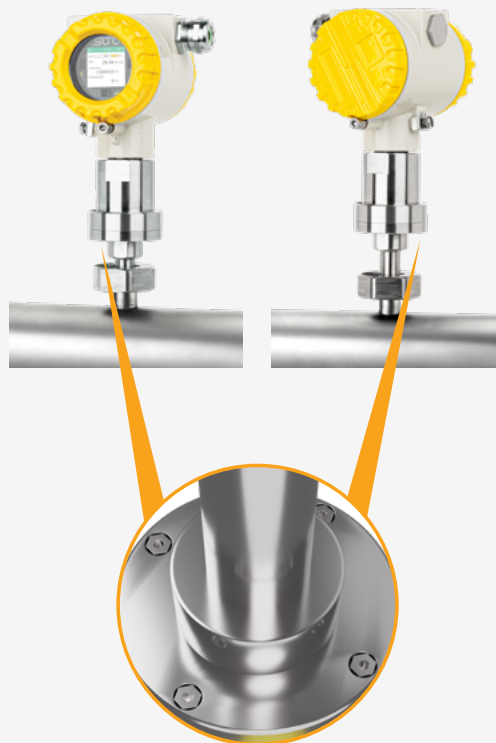



Industrial Communication

Enhance your connectivity with the advanced functionality of industrial communication via Modbus/RTU, while harnessing the power of Modbus/TCP over Ethernet/APL networks for seamless data exchange across your plant.

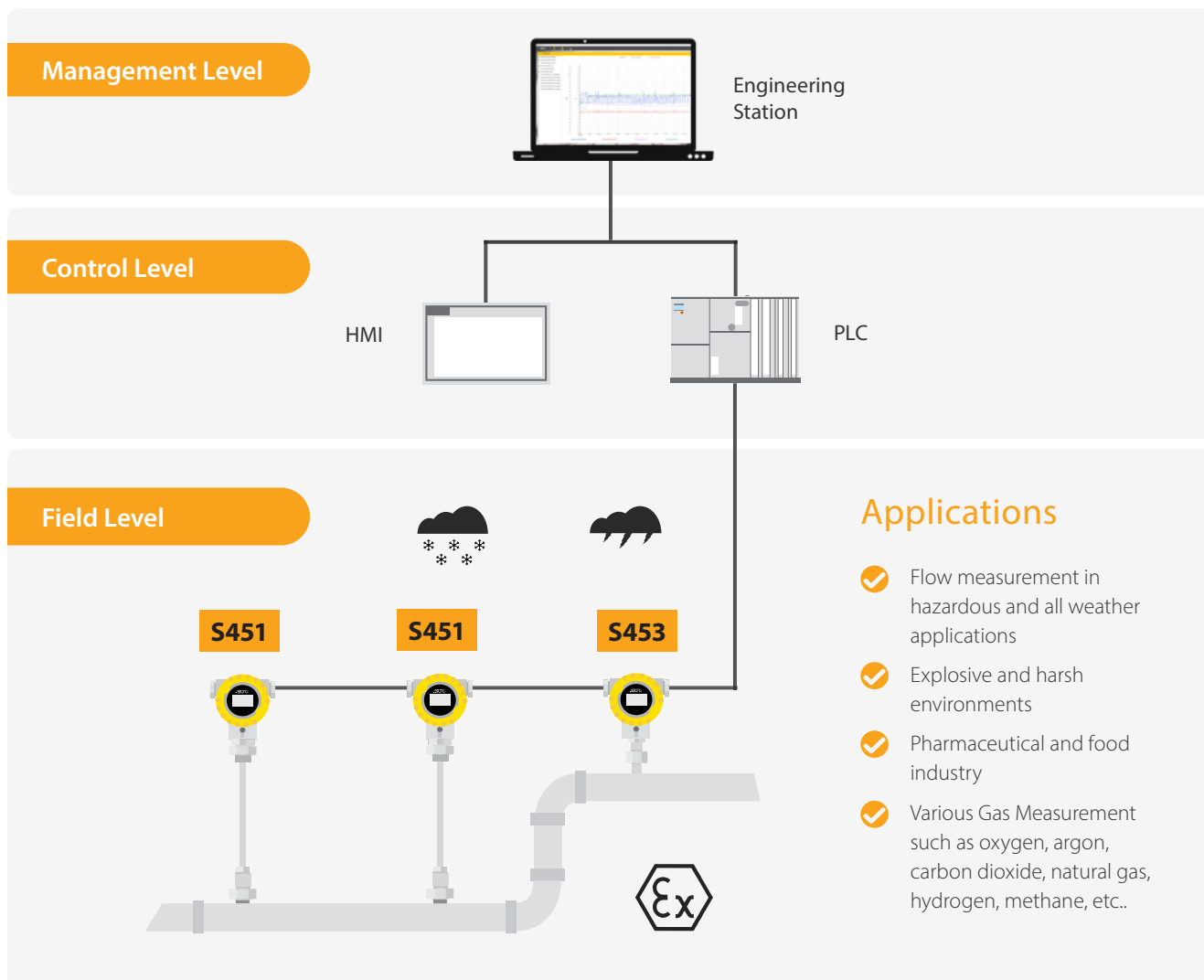

Applications

- ✓ Flow measurement in hazardous and all weather applications
- ✓ Explosive and harsh environments
- ✓ Pharmaceutical and food industry
- ✓ Various Gas Measurement such as oxygen, argon, carbon dioxide, natural gas, hydrogen, methane, etc..

Volumetric Flow Ranges

Tube		S451 Volumetric Flow Ranges		
Inch	DN	Low (m ³ /h)	Standard (m ³ /h)	Max (m ³ /h)
1"	DN25	0.6 ... 148	1.2 ... 295	1.82 ... 357
1½"	DN40	1.5 ... 367	2.9 ... 732	4.36 ... 886
2"	DN50	2.4 ... 600	4.8 ... 1,198	7.26 ... 1,450
2½"	DN65	4.1 ... 1,027	8.2 ... 2,049	12.1 ... 2,480
3"	DN80	5.7 ... 1,424	11.4 ... 2,841	16.9 ... 3,442
4"	DN100	8.7 ... 2,183	17.4 ... 4,357	24.2 ... 5,275
5"	DN125	20 ... 3,419	38 ... 6,824	45.9 ... 8,263
6"	DN150	20 ... 4,930	39 ... 9,839	70.18 ... 11,913
8"	DN200	35 ... 8,786	70 ... 17,533	106.48 ... 21,229
10"	DN250	55 ... 13,744	110 ... 27,429	165.77 ... 33,210
12"	DN300	79 ... 19,815	158 ... 39,544	239.58 ... 47,880

Tube		S453 Volumetric Flow Ranges		
Inch	DN	Low (m ³ /h)	Standard (m ³ /h)	Max (m ³ /h)
1"	DN25	0.6 ... 148	1.2 ... 295	1.82 ... 357
1½"	DN40	1.5 ... 367	2.9 ... 732	4.36 ... 886
2"	DN50	2.4 ... 600	4.8 ... 1,198	7.26 ... 1,450
2½"	DN65	4.1 ... 1,027	8.2 ... 2,049	N/A
3"	DN80	5.7 ... 1,424	11.4 ... 2,841	N/A

Stated measuring ranges under following conditions:

- Standard flow in air
- Reference pressure: 1000 hPa, reference temperature: +20 °C
- At other conditions and other gases the flow range is different. Please use flow range calculator on SUTO website for calculation.
- Flow measurement in pipes larger than DN300 are also supported, by using the 100 mm insertion depth setting.



S451 Dimensions

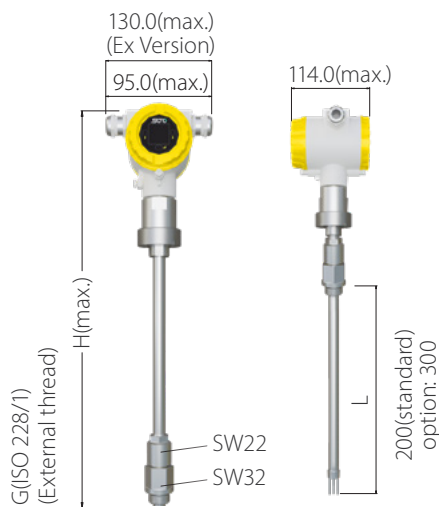

Shaft option (mm)	H (mm)	Diameter (mm)	SW
200	471	15	G 3/4"
300	571	15	G 3/4"

S453 Dimensions (Thread Type)

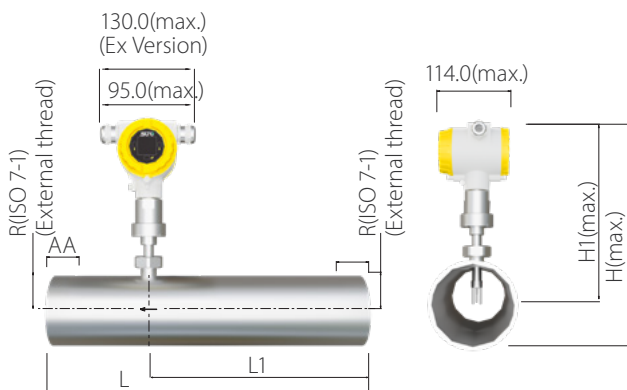

Pipe inch / (DN)	L (mm)	L1 (mm)	H (mm)	H1 (mm)	R
1" (DN25)	475	275	299	282	R 1"
1¼" (DN32)	475	275	303	282	R 1¼"
1½" (DN40)	475	275	306	282	R 1½"
2" (DN50)	475	275	312	282	R 2"
2½" (DN65)	475	275	320	282	R 2½"
3" (DN80)	475	275	326.5	282	R 3"

S453 Dimensions (Flange Type)

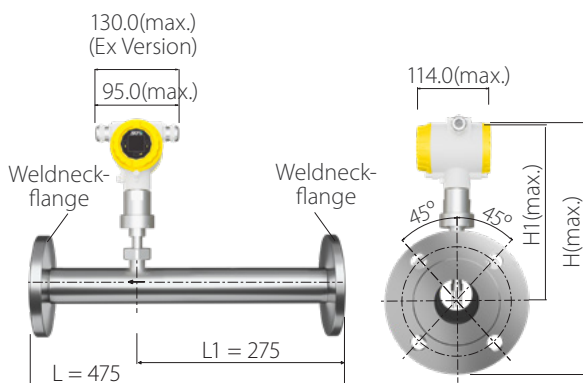

Pipe inch / (DN)	L (mm)	L1 (mm)	H (mm)	H1 (mm)
1" (DN25)	475	275	339.5	282
1¼" (DN32)	475	275	352	282
1½" (DN40)	475	275	357	282
2" (DN50)	475	275	364.5	282
2½" (DN65)	475	275	374.5	282
3" (DN80)	475	275	382	282



Technical Data

Measurement

Flow

Accuracy	±(1.5 % of reading + 0.3 % full scale)
Selectable units	m ³ /h, m ³ /min, l/min, l/s, cfm, kg/h, kg/min, kg/s
Repeatability	0.25 % o.RDG
Sensor	Thermal mass flow sensor
Sampling rate	3 samples / sec
Turn-down ratio	200:1
Response time (t90)	0.5 sec

Consumption

Selectable units	m ³ , ft ³ , l, kg
------------------	--

Reference conditions

Selectable conditions	20 °C 1000 mbar (ISO1217), 0 °C 1013 mbar (DIN1343) freely adjustable
-----------------------	---

Signal / Interface & Supply

Analog output

Signal	2 x 4 ... 20 mA (4-wire), isolated
Scaling	0 ... max flow, freely adjustable
Load	Max. 400 Ohm
Update rate	Value updated ever 1 sec

Pulse/Alarm output

Signal	Switch output, normally open, max. 30 VDC, 200 mA
Scaling	1 pulse per consumption unit (selectable)
Alarm	Channel and threshold freely setable

Fieldbus

Protocol	Modbus/RTU, Modbus/TCP
----------	------------------------

Supply

Voltage supply	16 ... 30 VDC
Current consumption	200 mA

General data

Configuration

Wireless	S4C-FS App for Android and iOS
Others	3 touch button at display

Display

Integrated	Color graphics display
------------	------------------------

Material

Process connection	Stainless steel 1.4404 (SUS 316L)
Housing	Al alloy
Sensor	Stainless steel 1.4404 (SUS316L), 4J50 nickel plated, glass
Metal parts	Stainless steel 1.4404 (SUS 316L)

Miscellaneous

Electrical connection	Screw terminals
Protection class	IP67, Ex option: IP65
Approvals	CE, RoHS, FCC, Ex-Options
Process connection	S451: G3/4" (ISO 228/1) S453: Measuring section with R-thread or Flange

Weight	S451 300mm:	2.15kg
	S451 200mm:	2.08kg
	S453 with section:	1.86kg

Operating conditions

Medium	Air, N ₂ , O ₂ , CO ₂ and other non corrosive gases
Medium temperature	S451: -40 ... +100 °C S453: -40 ... +100 °C
Medium humidity	< 90 %, no condensation
Operating pressure	0 ... 1.6 MPa applicable for Ex-Option 0 ... 5.0 MPa applicable for Non-Ex-Option* *For pressure above 1.5 MPa use the installation device A530 1106 or A530 1113 to install S451.
Ambient temperature	-40 ... +65 °C
Storage temperature	-30 ... +70 °C
Transport temperature	-30 ... 70 °C
Pipe sizes	S451: ≥ DN25 S453: DN25 ... DN80



Ordering

Please use the following tables to assist in placing your order with our sales staff.

S451 Thermal Mass Flow Meter (Insertion type)

Order No.	Description
KA66S6954510	S451 Thermal mass flow meter (Insertion Type), incl. Display, Data Logger, Flow Medium 1: Air, 200 mm shaft
KA66S6954511	S451 Thermal mass flow meter (Insertion Type), incl. Display, Data Logger, Flow Medium 1: Air, 300 mm shaft

Pressure Measurement (integrated)

KA66000A1558	Integrated pressure sensor, 0 ... 1.6 MPa(g) [16 bar (g)]
KA66000A1559	Integrated pressure sensor, 0 ... 5.0 MPa(g) [50 bar (g)]

Flow Medium 2

KA66000A1003	No Second Gas
KA66000A1008	CO ₂
KA66000A1009	O ₂ (Oil- & grease-free cleaned)
KA66000A1010	N ₂
KA66000A1011	N ₂ O
KA66000A1012	Argon
KA66000A1013	Natural Gas
KA66000A1014	H ₂ (real gas calibration)
KA66000A1015	Other gas (please specify)
KA66000A1016	He (real gas calibration)
KA66000A1017	C ₃ H ₈
KA66000A1041	O ₂ , Ar, CO ₂ (real gas calibration)
KA66000A1042	CH ₄ , NG, N ₂ O (real gas calibration, please consult with manufacturer for this option in advance)

Range

KA66000A1555	Low Range (30 sm/s)
KA66000A1554	Standard Range (120 sm/s)
KA66000A1550	Max Range (240 sm/s)

Calibration

KA66000A1553	Standard Calibration
KA66000A1551	High accuracy calibration (1% o. rdg + 0.3% FS)
KA66000A1552	Bi-directional calibration

Output

KA66000A1560	2 x 4 ... 20 mA, Pulse/Alarm, Modbus/RTU
KA66000A1561	2 x 4 ... 20 mA, Pulse/Alarm, Modbus/TCP over Ethernet APL

Ex-Approval

KA66000A1557	No Ex-Approval
KA66000A1556	ATEX / IECEx / GB3836

Accessories

Order No.	Description
KA66R2000005	Oil- & grease-free cleaned option for flow sensors (for Oxygen it is already included in A 1009)
KA66A5301106	High pressure installation device S451, 200 mm (to be used if pressure above 1.5 MPa)
KA66A5301113	High pressure installation device S451, 300 mm (to be used if pressure > 1.5 MPa)

Ordering Example

KA66S6954510	S451 Thermal mass flow meter (Insertion Type), incl. Display, Data Logger, Flow Medium 1: Air, 200 mm shaft
KA66000A1003	No Second Gas
KA66000A1554	Standard Range (120 sm/s)
KA66000A1553	Standard Calibration
KA66000A1560	2 x 4 ... 20 mA, Pulse/Alarm, Modbus/RTU
KA66000A1557	No Ex-Approval



Ordering

Please use the following tables to assist in placing your order with our sales staff.

S453 Thermal Mass Flow Meter (In-line type)

Order No.	Description
KA66S6954530	S453 Thermal mass flow meter (In-Line Type), incl. Display, Data Logger, Flow Medium 1: Air

Measuring Section Connection

KA66000A152X	R-thread (ISO 7-1)
KA66000A153X	Flange, EN 1092-1, PN40
KA66000A154X	Flange ANSI 16.5

Measuring Section Size

3	DN25 (1")
4	DN32 (1.25")
5	DN40 (1.5")
6	DN50 (2")
7	DN65 (2.5")
8	DN80 (3")

Pressure Measurement (integrated)

KA66000A1558	Integrated pressure sensor, 0 ... 1.6 MPa(g) [16 bar(g)]
KA66000A1559	Integrated pressure sensor, 0 ... 5.0 MPa(g) [50 bar(g)]

Flow Medium 2

KA66000A1003	No Second Gas
KA66000A1008	CO ₂
KA66000A1009	O ₂ (Oil- & grease-free cleaned)
KA66000A1010	N ₂
KA66000A1011	N ₂ O
KA66000A1012	Argon
KA66000A1013	Natural Gas
KA66000A1014	H ₂ (real gas calibration)
KA66000A1015	Other gas (please specify)
KA66000A1016	He (real gas calibration)
KA66000A1017	C ₃ H ₈
KA66000A1041	O ₂ , Ar, CO ₂ (real gas calibration)
KA66000A1042	CH ₄ , NG, N ₂ O (real gas calibration, please consult with manufacturer for this option in advance)

Range

KA66000A1555	Low Range (30 sm/s)
KA66000A1554	Standard Range (120 sm/s)
KA66000A1550	Max Range (240 sm/s)

Calibration

KA66000A1553	Standard Calibration
KA66000A1551	High accuracy calibration (1% o. rdg +- 0.3% FS)

Output

KA66000A1560	2 x 4 ... 20 mA, Pulse/Alarm, Modbus/RTU
KA66000A1561	2 x 4 ... 20 mA, Pulse/Alarm, Modbus/TCP over Ethernet APL

Ex-Approval

KA66000A1557	No Ex-Approval
KA66000A1556	ATEX / IECEx / GB3836

Accessories

Order No.	Description
KA66R2000005	Oil- & grease-free cleaned option for flow sensors (for Oxygen it is already included in KA66000A1009)

Ordering Example

KA66S6954530	S453 Thermal mass flow meter (In-Line Type), incl. Display, Data Logger, Flow Medium 1: Air
KA66000A1526	R-thread (ISO 7-1), DN50 (2")
KA66000A1558	Integrated pressure sensor, 0 ... 16 bar(g)]
KA66000A1003	No Second Gas
KA66000A1554	Standard Range (120 sm/s)
KA66000A1553	Standard Calibration
KA66000A1560	2 x 4 ... 20 mA, Pulse/Alarm, Modbus/RTU
KA66000A1556	ATEX / IECEx / GB3836



www.kompauto.com



sales@kompauto.com



S430



Pitot Tube Flow Meter for Wet Compressed Air

Insertion

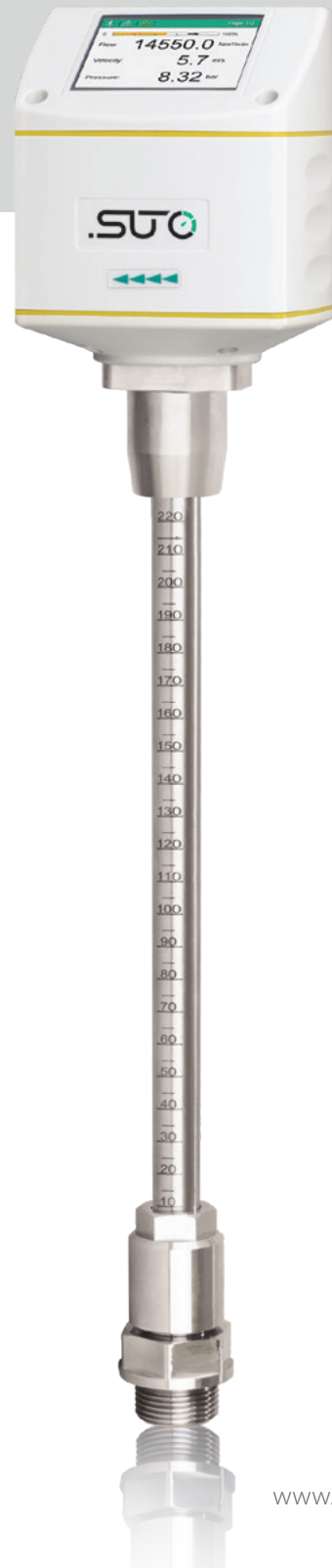

PROCESS MONITORING
High accuracy and reliable measurements



WET AIR MEASUREMENT
Directly at the compressor outlet



COMPRESSOR EFFICIENCY
Constant monitoring of the compressor performance



MOBILE APP
For remote configuration and monitoring



EASY INSTALLATION
Under pressure through a ball valve



NO MECHANICAL WEAR PARTS
Stable results in high temperature applications



Benefits

- ✓ Accurate flow and consumption measurement in wet air or high mass flow and velocity applications based on the pitot tube principle
- ✓ Consistent and temperature stable compressed air flow monitoring at the outlet of the compressor
- ✓ Various output signals with connection to SUTO displays and/or third-party displays and PLCs
- ✓ Easy installation under pressure through ball valve
- ✓ High temperature applications up to 230 °C

1 Optional Color Display

On-site display for live value readings, total consumption counter and convenient sensor settings. Totalizer with 10 digits (1 999 999 999).

2 Various Outputs

The S430 pitot tube flow meter is perfectly suited to be integrated into process controls or high-level monitoring systems. Various output options are offered for a seamless integration:

- Isolated 4... 20 mA output for actual flow readings
- Isolated Pulse output for totalizer
- Modbus/RTU to read all values digitally
- Modbus/TCP
- M-BUs

3 Robust Materials

- IP65 casing provides robust protection in rough industrial environment
- All parts which come into contact with the measurement medium are made of stainless steel 316L. This makes the sensors robust and guarantees a reliable measurement.

4 Flexible and Easy Installation

- Tube diameters of 1.25" to 10" through center installation, bigger diameters through non-center installation
- Thanks to the insertion through a 3/4" ball valve, the S430 can be installed and under pressure and is perfectly suited for installations where shutdowns are not acceptable.



Configuration through smartphone app



S430

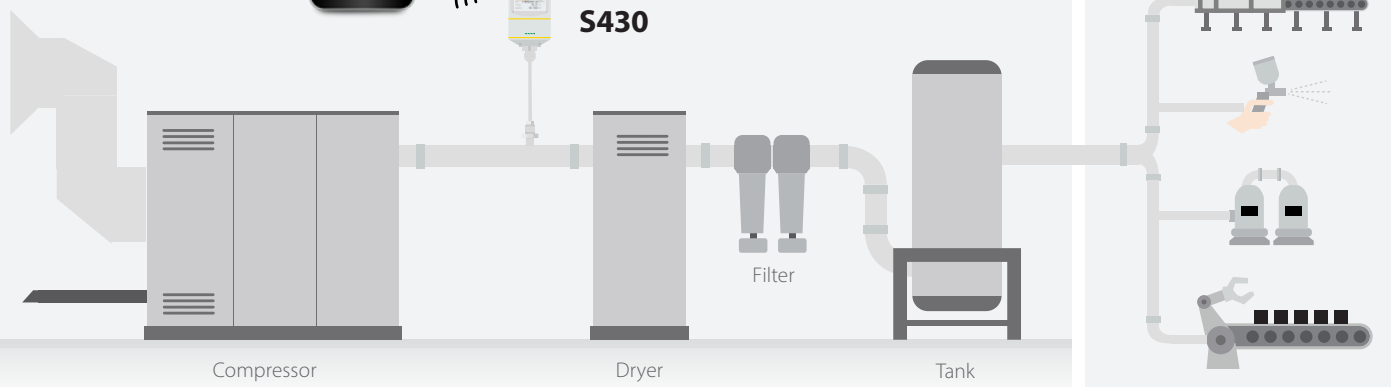



S430 Installation and Sensor Removal

Installation through a ball valve

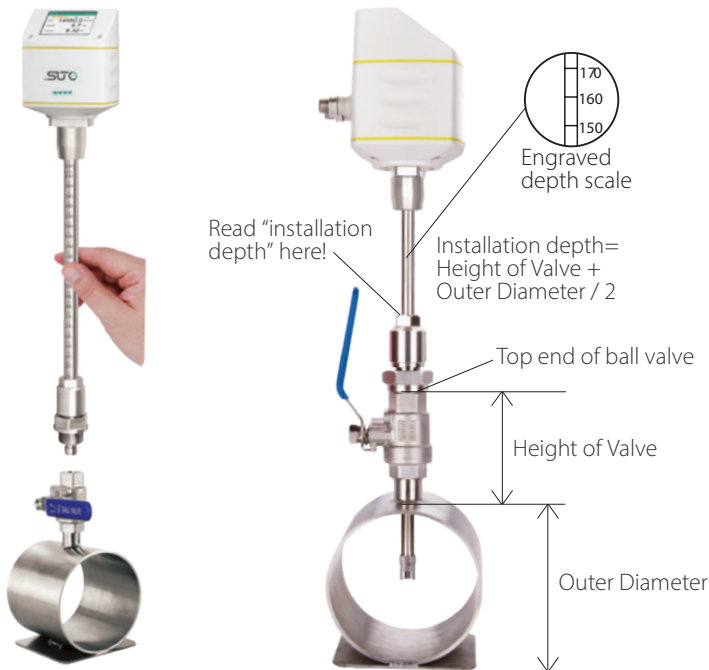

S430 Dimensions

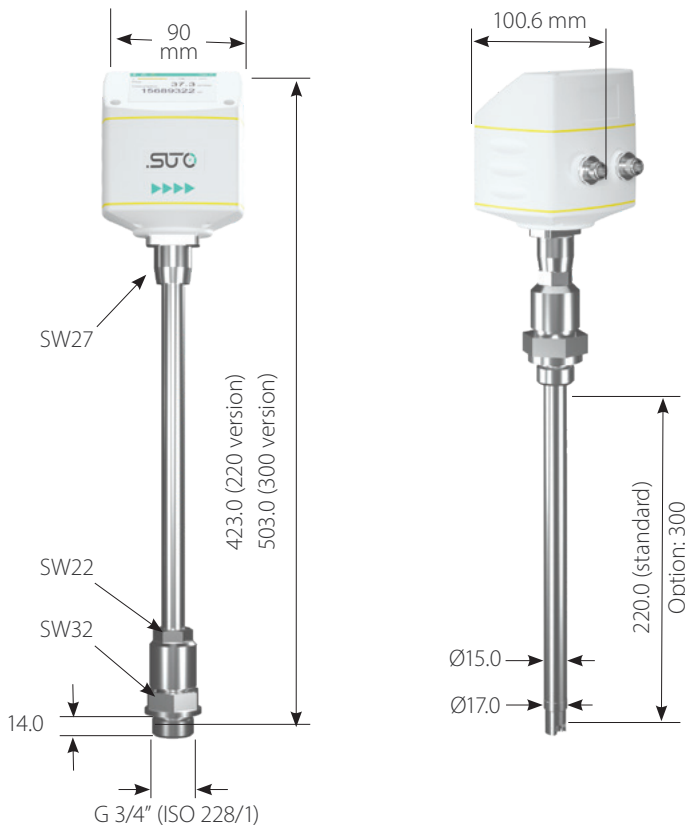

Mobile App

Mobile Phone app for configuration and online readings. The app enable users to completely get rid of the inconvenience caused by cables, bulky PCs and hard-to-reach places.



Based on the pitot tube principle

The S430 is based on the pitot tube principle to measure flow. Properly installed (refer to instruction manual for details) the sensor can measure in wet and dirty gases as occurring, for example, at the discharge of a compressor.

Optional Color Display



Colour graphic display for online values and sensor settings



Connect several Flow Meters to Modbus Master

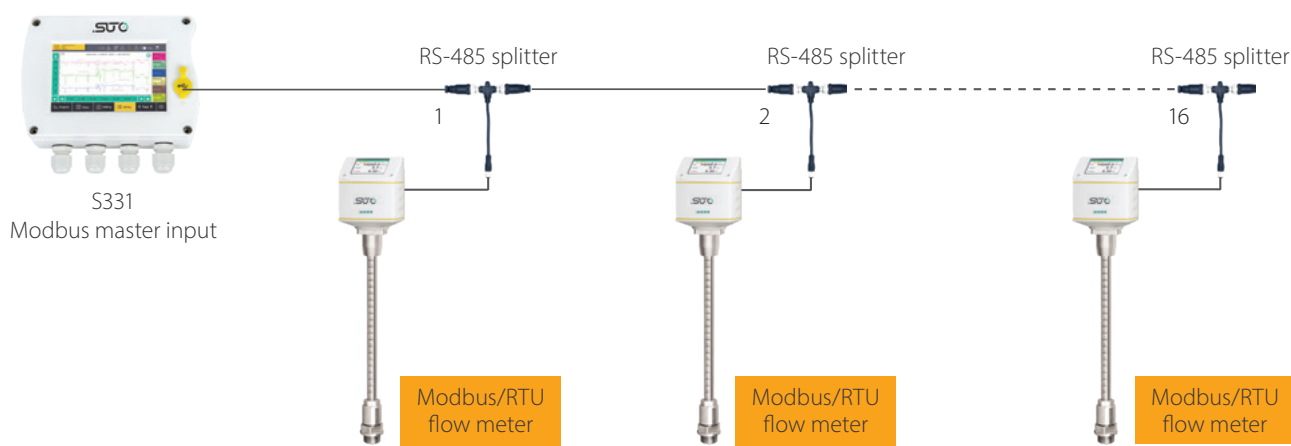

Flow meters can be easily integrated into a Modbus/RTU network (daisy chain)

Volumetric Flow Ranges

Tube		Volumetric Flow					
Inch	mm	m ³ /h		m ³ /min		cfm	
		Min	Max	Min	Max	Min	Max
1¼"	36	49	507	0.8	8.5	29	298
1½"	41.9	73	757	1.2	12.6	43	446
2"	53.1	124	1298	2.1	21.6	73	764
2½"	68.9	221	2311	3.7	38.5	130	1360
3"	80.9	313	3270	5.2	54.5	184	1925
4"	100	488	5094	8.1	84.9	287	2998
5"	125	767	8006	12.8	133	451	4712
6"	150	1107	11547	18.5	192	652	6796
8"	200	1983	20689	33.1	345	1167	12177
10"	250	3099	32338	51.7	539	1824	19034
12"	300	4462	46567	74.4	776	2626	27408

Stated measuring ranges under following conditions:

- Standard flow in air
- Reference pressure: 1000 hPa
- Reference Temperature: +20 °C

Flow range is calculated for Air at 6 bar(g), 50 °C and 90 % humidity.

Mobile Power

S430 powered by power bank with connection cable KA66A5530154.
Note: power bank must be sourced locally due to shipping restrictions [USB-C, 20 V, min. 100 mA]





Technical Data

Measurement

Flow

Accuracy	1.5 % o.r. ± 0.3 % FS Volumetric Flow: m ³ /h, m ³ /min, L/min, l/s, cfm Mass Flow: kg/h, kg/min, kg/s, t/h, lb/h
----------	---

Selectable units	Actual Velocity: m/s, ft/min
------------------	------------------------------

Measuring range	see table on the previous page
-----------------	--------------------------------

Repeatability	0.5 % o.r.
---------------	------------

Sensor	Differential pressure sensor
--------	------------------------------

Sampling rate	3/sec
---------------	-------

Turndown ratio	10:1
----------------	------

Response time (t ₉₀)	2 sec
----------------------------------	-------

Consumption

Selectable units	m ³ , ft ³ , t, lb, l, kg
------------------	---

Reference conditions

Selectable conditions	20 °C 1000 mbar (ISO1217) 0 °C 1013 mbar (DIN1343) freely adjustable
-----------------------	--

Signal / Interface & Supply

Analog output

Signal	4 ... 20 mA, isolated
--------	-----------------------

Scaling	0 ... max flow
---------	----------------

Load	250R
------	------

Update rate	1/sec
-------------	-------

Pulse output

Signal	Max 30 V, 200 mA
--------	------------------

Scaling	1 pulse per consumption unit
---------	------------------------------

Fieldbus

Protocol	Modbus/RTU, Modbus/TCP
----------	------------------------

Update rate

Supply

Voltage supply	24 VDC 48 VDC (PoE)
----------------	------------------------

Current consumption	150 mA 100 mA (PoE)
---------------------	------------------------

General data

Configuration

Wireless	S4C-FS App for mobile phones
----------	------------------------------

Others	Display with 3 touch buttons (Option)
--------	---------------------------------------

Display

Integrated	2.4" color graphic display with 3 touch buttons (option)
------------	---

Material

Process connection	Stainless steel 1.4404 (SUS 316L)
--------------------	-----------------------------------

Housing	PC + ABS
---------	----------

Sensor	Stainless steel 1.4404 (SUS 316L)
--------	-----------------------------------

Metal parts	Stainless steel 1.4404 (SUS 316L)
-------------	-----------------------------------

Miscellaneous

Electrical connection	2 x M12 (5 pole) 1 x M12 (8-pole x-coded) for TCP
-----------------------	--

Protection class	IP65
------------------	------

Approvals	CE, RoHS, FCC
-----------	---------------

Process connection	G 3/4" (ISO 228/1)
--------------------	--------------------

Weight	1.12 kg
--------	---------

Operating conditions

Medium	Wet/dry air, other gases
--------	--------------------------

Medium quality	non corrosive
----------------	---------------

Medium temperature	-40 ... +230 °C
--------------------	-----------------

Medium humidity	no requirements
-----------------	-----------------

Operating pressure	0 ... 1.6 MPa -30 ... +70 °C housing 0 ... +50 °C display (Optional)
--------------------	--

Ambient temperature	-10 ... +40 °C PoE (Optional)
---------------------	-------------------------------

Ambient humidity	< 95 % rH
------------------	-----------

Storage temperature	-30 ... 70 °C
---------------------	---------------

Transport temperature	-30 ... 70 °C
-----------------------	---------------

Pipe sizes	\geq DN32
------------	-------------



Ordering

Please use the following tables to assist in placing your order with our sales staff.

S430 Pitot Tube Flow Sensor (Insertion Type)

Order No. Description

KA66S6954300	S430, Pitot Tube Flow Meter, insertion type, 220 mm shaft
KA66S6954302	S430, Pitot Tube Flow Meter, insertion type, 300 mm shaft

Flow Medium

KA66000A1007	Option, flow medium Air
KA66000A1008	Option, flow medium CO ₂
KA66000A1009	Option, flow medium O ₂ (cleaning for oil and grease-free)
KA66000A1010	Option, flow medium N ₂
KA66000A1011	Option, flow medium N ₂ O
KA66000A1012	Option, flow medium Argon
KA66000A1013	Option, flow medium Natural Gas
KA66000A1014	Option, flow medium H ₂ (For real gas calibration. Please consult manufacturer for this option in advance)
KA66000A1015	Other gas (specify gas or gas mix)
KA66000A1016	Option, flow medium He (real gas calibration)

Range / Calibration

KA66000A1066	S430: Bi-directional standard range
KA66000A1067	S430: High speed: Max flow increased by 30 %

Output

KA66000A1061	S430: Modbus/RTU
KA66000A1062	S430: Analog, Pulse
KA66000A1063	S430: M-Bus
KA66000A1064	S430: Modbus/TCP + PoE support (incl. 5 m M12 cable with RJ45 plug)

Display

KA66000A1060	S430: With Display
--------------	--------------------

Accessories

KA66A6950010	S430: NPT 3/4" thread adapter (former A1069)
KA66A6950011	S430: PT 3/4" thread adapter (former A1068)
KA66A5530104	Sensor cable, 5 m with M12 connector, open wires, AWG 24 (0.2 mm ²)
KA66A5530105	Sensor cable, 10 m with M12 connector, open wires, AWG 24 (0.2 mm ²)
KA66A5530154	Cable to connect power bank, 1.8 m, USB-C connector for power bank, M12 connector

Example: S430, 300 mm shaft, Air, bi-directional calibration, Modbus/RTU, display

Order Code: KA66S6954302
 KA66000A1007
 KA66000A1066
 KA66000A1061
 KA66000A1060



www.kompauto.com



sales@kompauto.com



S409



Thermal Mass Flow Direction Switch

Insertion



NO MECHANICAL WEAR PARTS
Robust Design



FLOW DIRECTION
Reliable indication



EASY INSTALLATION
Under pressure



RELAY OUTPUT
1 relay for each direction



Benefits

- ✓ Accurate and fast detection of the flow direction
- ✓ Detects smallest changes < 0.1 m/s referred to 20 °C and 1000 hpa
- ✓ No mechanical wear parts for long term stable measurements
- ✓ Easy installation under pressure without stopping the operation

1 Robust Materials

IP65 casing provides robust protection in rough industrial environments to ensure reliable measurement results.

2 Flexible Installation

Through a 1/2"G-type ball valve the switch can be inserted into the pipe under pressure without shutting down the system.

3 Thermal Mass Flow Sensor

The thermal mass flow sensor element comes with main advantages:

- Very robust and completely of stainless steel
- Fast response times and wide measuring range at high accuracy
- Minimal pressure loss



4 Connection

Pin assignment connector

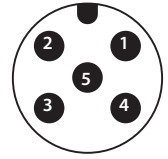

Pin arrangement of flow switch

	Pin1	Pin2	Pin3	Pin4	Pin5
A	SDI	-VB	+VB	DIR1	DIR1
B	SDI	-VB	+VB	DIR2	DIR2

Relay output at switch

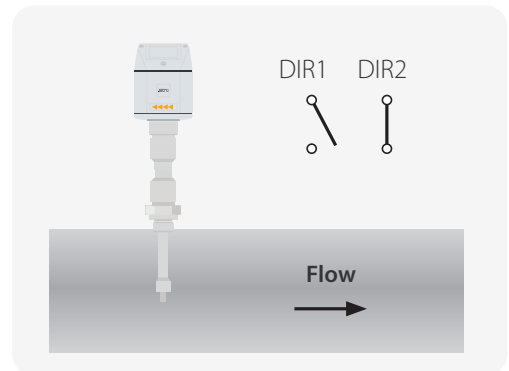
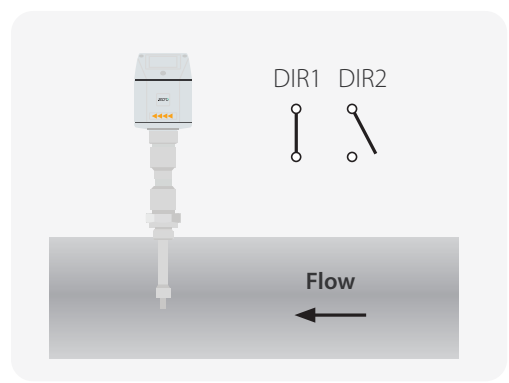

Operation Principle

The thermal mass flow direction switch S409 allows the detection of direction of the flow. It can be used in compressed air and non-corrosive gases.

The flow and direction information is output through 2 normally open relay switches. The signals can be transferred to the SUTO flow sensor to activate and deactivate the flow measurement depending on the flow direction, as well as triggering which consumption counter is used.



Connection of S330 to S450 via flow switch

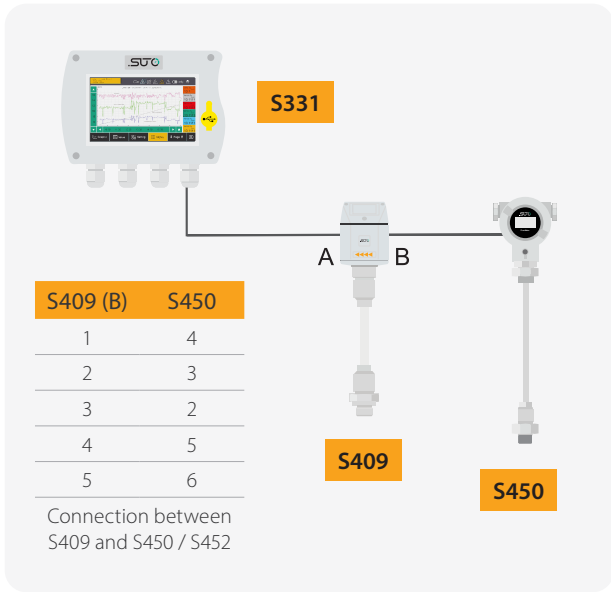

Connection of S330 to S401 with flow switch

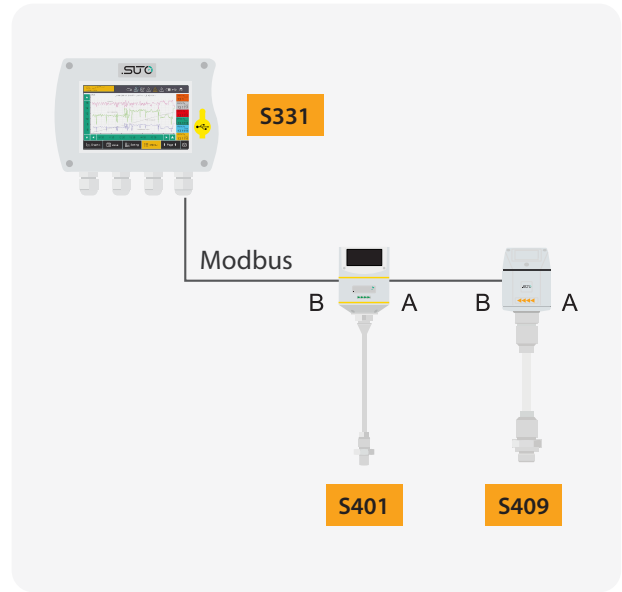

Attention: Flow sensors S450 / S401 need to have the bi-directional calibration option to operate in both directions

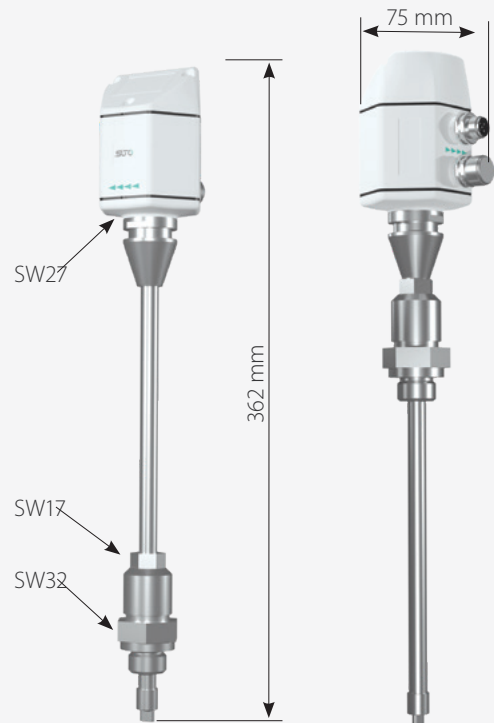



Technical Data

Measurement

Flow Direction Detection

Accuracy	0.05 m/s
Measuring range	0.02 ... 25 m/s @ 7barg, 20 °C
Sensor	2 x Pt 1000

Signal / Interface & Supply

Switch output

Relay	2 x isolated direction switches
Rating	60 VDC, 1 A

Supply

Voltage supply	24 VDC
Current consumption	160 mA

General data

Material

Process connection	G½" (ISO 228-1)
Housing	PC + ABS
Sensor	Ceramic sensor, glass coated
Metal parts	Stainless steel 1.4404 (SUS 316L)

Miscellaneous

Electrical connection	2 x M12 5-pole
Protection class	IP65
Approvals	CE
Process connection	½" G (ISO 228-1)
Weight	500 g

Operating conditions

Medium	air, gases
Medium quality	ISO 8573: 4.4.3 or better
Medium temperature	-20 ... +80 °C
Medium humidity	< 100 % (no condensation)
Operating pressure	0 ... 1.6 MPa
Ambient temperature	-20 ... +70 °C
Ambient humidity	< 99 % (no condensation)
Storage temperature	-40 ... +70 °C
Transport temperature	-40 ... +70 °C
Pipe sizes	½ to 12 (bigger diameters on request)

Ordering

Please use the following table to assist in placing your order with our sales staff.

S409 Thermal Mass Flow Direction Switch (Insertion)

Order No. Description

KA66S6950409	S409 Thermal Mass Flow Direction Switch, insertion type
KA66A5530104	Sensor cable 5 m, with M12 connector, open wires, AWG 24 (0.2 mm ²)
KA66A5530105	Sensor cable 10 m, with M12 connector, open wires, AWG 24 (0.2 mm ²)



www.kompauto.com



sales@kompauto.com



S435



Vortex Flow Meter for Steam

Wafer type



INTERGRATED TEMPERATURE SENSOR

Automatic density adjustment

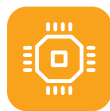

EASY PROCESS MONITORING

Effective and inexpensive measurements



ACCURATE RESULTS

Very fast response time



TOTAL FLOW

High accuracy and reliable measurements



LOCAL DISPLAY

For easy configuration and live values

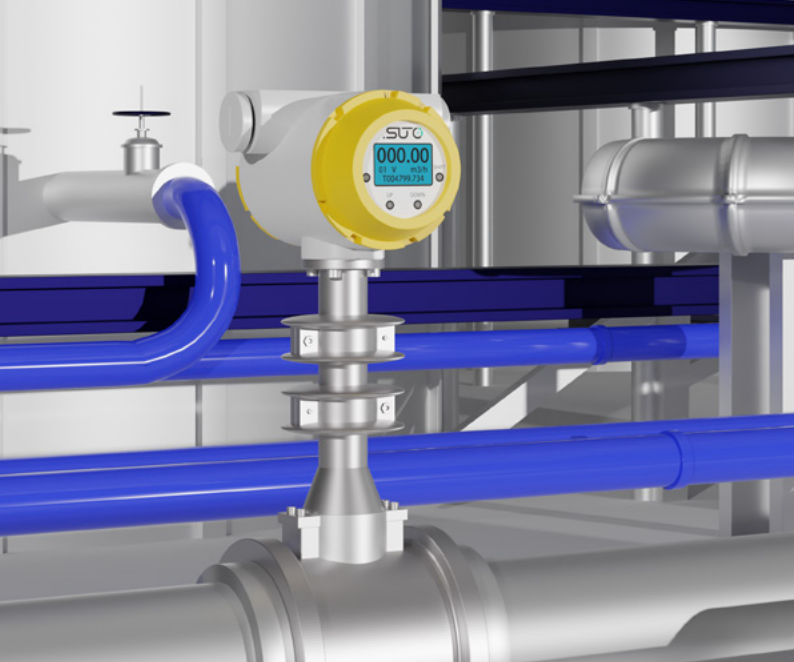

Benefits

- ✓ Accurate saturated steam measurement by instant flow and consumption monitoring
- ✓ Integrated temperature sensor and small pressure loss
- ✓ High protection level due to robust industrial design and no moving parts
- ✓ Analog and Modbus output for data logging and analysis
- ✓ Wafer type makes it easy for installation

Accurate Steam Monitoring

Vortex flow meters are the ideal choice for steam measurements due to their robust design, without any moving parts and high temperature/pressure resistance.

S435 provides mass flow and consumption measurements in saturated steam with automatic density compensation. This always guarantees accurate results. Parameter settings can be done through the user interface (keys and display) at the flow meter directly. Connection to an SCADA system is through the Modbus/RTU interface or the analog output available.

Please ensure that the steam parameters such as temperature, pressure and nominal flow are within the specification of S435.

Installation

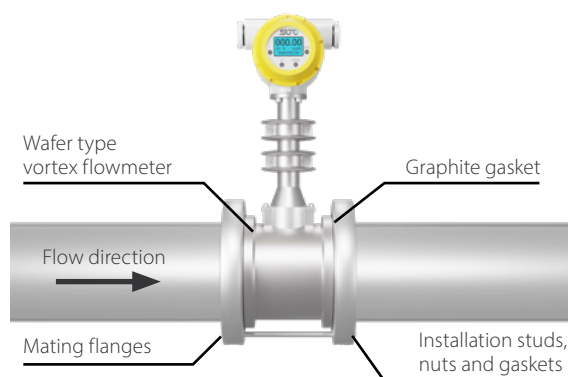

Use double bolts and nuts. We provide gaskets and bolts.

Dimensions

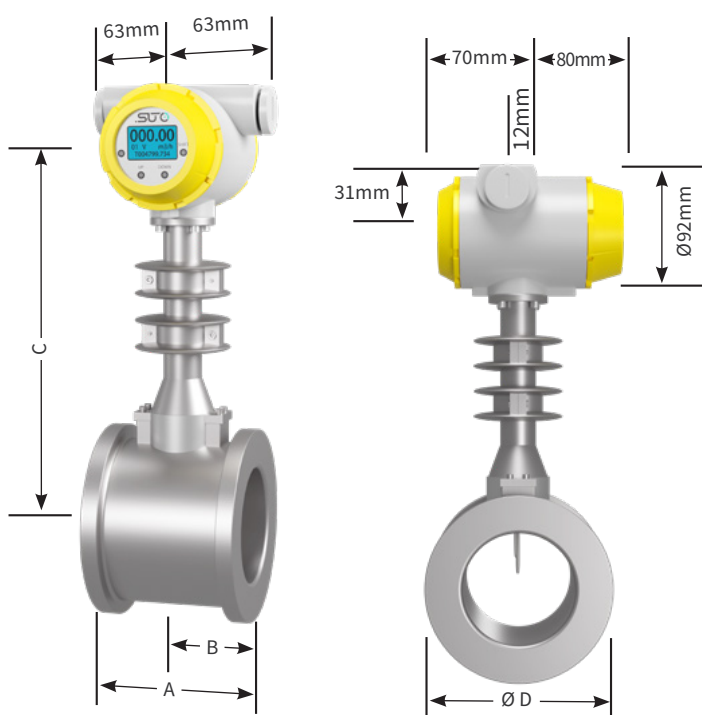

Vortex Flow Meter dimension rated pressure 1.6 Mpa unit: mm

DN	A	B	C	D
40	100	50	256	75
50	110	55	256	87
65	110	55	262	109
80	110	55	267	120
100	120	60	271	149
125	133	73	291	175
150	160	90	304	203
200	185	115	331	259
250	210	140	357	312
300	240	165	383	363



Technical Data

Measurement

Flow

Accuracy	1.5 % of reading
Selectable units	m ³ /h, m ³ /min, kg/h, t/h
Measuring range	see table below
Repeatability	0.5 % o.RDG
Sensor	Vortex
Turndown ratio	1:10

Consumption

Selectable units	m ³ , kg, t
------------------	------------------------

Signal / Interface & Supply

Analog output

Signal	4 ... 20 mA (4-wire), isolated
Scaling	0 ... max flow, freely adjustable
Update rate	Value updated ever 1 sec

Frequency output

Measuring range	0~5000 Hz
-----------------	-----------

Fieldbus

Protocol	Modbus/RTU
Update rate	Value updated ever 1 sec

Supply

Voltage supply	24VDC
----------------	-------

General data

Display

Integrated	LCD display
------------	-------------

Material

Process connection	Carbon steel /304/316/316L(Flange/Wafer)
Housing	SUS 304
Sensor	SUS 316
Metal parts	SUS 304

Miscellaneous

Electrical connection	1/2"-14NPT
Protection class	IP65
Process connection	wafer
Weight	depends on pipe size - please enquire if needed

Operating conditions

Medium	Saturated steam
Medium temperature	-40 ... +250 °C
Operating pressure	0 ... 1.6 MPa (applicable for option 2.5MPa or 4.0MPa)
Ambient temperature	-10 ... +60 °C
Ambient humidity	< 99 % rH
Storage temperature	-10 ... +60 °C
Transport temperature	-10 ... +60 °C
Pipe sizes	DN25 ... DN300

Measuring ranges

Saturated Steam Mass Flowrate (Unit: t/h)

DN (mm)	0.20 Mpa		0.50 Mpa		0.60 Mpa		0.70 Mpa		1.00 Mpa		1.50Mpa	
DN40	(28.8 ~ 329.8 kg/h)		(39.9 ~ 633.0 kg/h)		(42.9 ~ 732.5 kg/h)		0.05	0.83	0.05	1.13	0.06	1.61
DN50	0.04	0.52	0.06	0.99	0.07	1.14	0.07	1.29	0.08	1.76	0.1	2.52
DN65	0.08	0.87	0.11	1.67	0.11	1.93	0.12	2.18	0.14	2.97	0.17	4.26
DN80	0.12	1.32	0.16	2.53	0.17	2.93	0.18	3.3	0.21	4.5	0.25	6.45
DN100	0.18	2.06	0.25	3.96	0.27	4.58	0.28	5.16	0.33	7	0.4	10.08
DN125	0.28	3.22	0.39	6.18	0.42	7.15	0.44	8.06	0.52	11	0.62	15.76
DN150	0.4	4.64	0.56	8.9	0.6	10.3	0.64	11.61	0.75	15.83	0.9	22.69
DN200	0.72	8.25	1	15.83	1.07	18.31	1.14	20.64	1.33	28.14	1.59	40.34
DN250	1.12	12.88	1.56	24.73	1.68	28.61	1.78	32.25	2.1	44	2.49	63.03
DN300	1.62	18.55	2.24	35.61	2.41	41.2	2.56	46.45	3	63.3	3.58	90.76



Ordering

Please use the following table to assist in placing your order with our sales staff.

S435 Vortex Flow Meter for Steam (Inline)

Order No.	Description
KA66S6954359	S435 Vortex Flow Meter DN40, wafer type
KA66S6954350	S435 Vortex Flow Meter DN50, wafer type
KA66S6954351	S435 Vortex Flow Meter DN65, wafer type
KA66S6954352	S435 Vortex Flow Meter DN80, wafer type
KA66S6954353	S435 Vortex Flow Meter DN100, wafer type
KA66S6954354	S435 Vortex Flow Meter DN125, wafer type
KA66S6954355	S435 Vortex Flow Meter DN150, wafer type
KA66S6954356	S435 Vortex Flow Meter DN200, wafer type
KA66S6954357	S435 Vortex Flow Meter DN250, wafer type
KA66S6954358	S435 Vortex Flow Meter DN300, wafer type
KA66A6950001	Blind pipe for uninstillation - DN40&DN50
KA66A6950002	Blind pipe for uninstillation - DN65
KA66A6950003	Blind pipe for uninstillation - DN80
KA66A6950004	Blind pipe for uninstillation - DN100
KA66A6950005	Blind pipe for uninstillation - DN125
KA66A6950006	Blind pipe for uninstillation - DN150
KA66A6950007	Blind pipe for uninstillation - DN200

Notes:

All Flow meters: Wafer connection (Companion flange, bolt and gasket included), temperature compensation, local display, medium temperature <250 °C, 4-20 mA signal output, 1/2-14 NPT electric connection, IP65, accuracy +1.5 %, 24 VCD, Modbus/RTU, Pulse, for saturated steam only



www.kompauto.com



sales@kompauto.com



S461



Ultrasonic Flow Meter for Liquid

Clamp-on

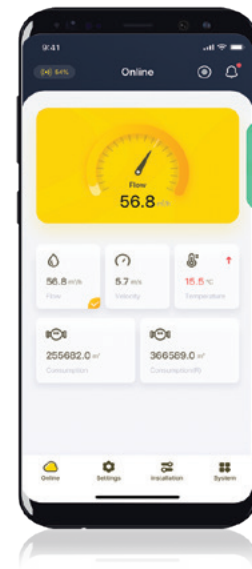

NON-INVASIVE MEASUREMENT
Through clamp-on sensors



SMARTPHONE APP
Easy configuration



ENERGY METER
Monitors of heat exchangers



COMPACT DESIGN
Can be installed anywhere



LOCAL DISPLAY
For instant values



DATA LOGGER
8 million samples



EASY INSTALLATION
Various installation options



Benefits

- ✔ Measures the actual flow and total consumption of various liquids
- ✔ The configuration through the dedicated smartphone app is easy and most user friendly
- ✔ Connectable to any monitoring system, through various signal interfaces: Modbus/RTU (standard), 4 ... 20 mA / Pulse / Alarm-Relay (option), Modbus/TCP (option)
- ✔ Flow and consumption can be measured in both directions, forward and reverse (Bi-directional measurement)
- ✔ Robust industrial design with versatile installation options for the display unit: Wall installation, DIN rail and pipe installation
- ✔ Measurement log files can be downloaded through the free S4A software. Soon a wireless readout will be available through mobile App

Accurate Liquid Measurement

The SUTO ultrasonic clamp-on flow meter S461 has all it takes to measure reliable, easy and accurate flow and consumption of liquids. Based on the transit time technology this flow meter comes with unique features and outstanding performance.

The transducers are simply clamped onto the outside of the pipe and never come in contact with the fluid. The main unit is either installed onto the pipe as well, at the wall or onto a DIN rail.

The configuration and setup is made through the wireless smartphone app S4C-US which can be downloaded for free from the SUTO website, Google Play Store and the Apple App Store. The app allows the user to set up the device as well as reading live values, logger configuration and logger data read out.

By adding 2 clamp-on temperature sensors the Energy Meter Version monitors the efficiency of heat exchangers.

The S461 comes also as portable version in a transport case.

Transit Time Principle

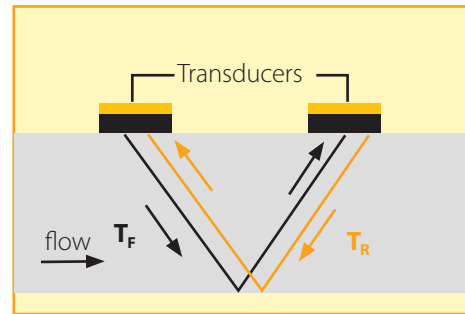

T_F : time in flow direction
 T_R : time in reverse flow direction

A number of pulses are transmitted from one transducer to the other and vice-versa. Sound waves travel faster with the direction of flow and slower against the direction of flow.

Mobile App

Instant view of daily, weekly and monthly consumption through mobile app.

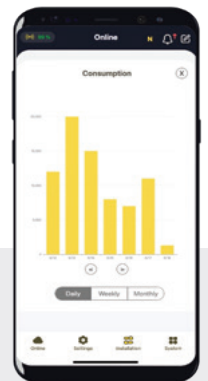

S461 and transducers mounted on pipe





Heat Recovery Principle

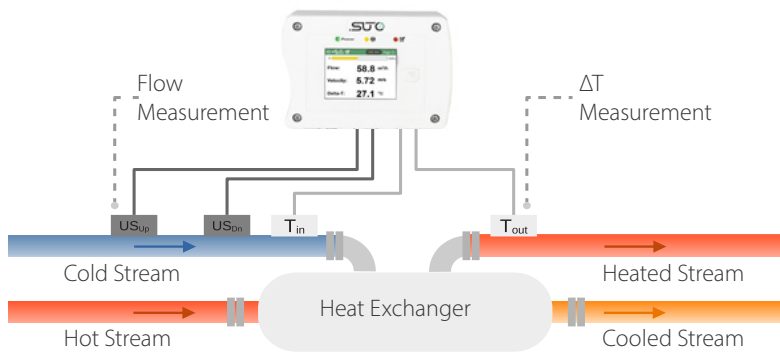

Principle heat recovery measurement with S461 Energy Meter

Heat exchangers transfer heat (energy) from a higher temperature medium (hot stream) to a colder one (heated stream). S461 measures the flow rate and the temperature difference between cold stream and heated stream. Based on these measurements the recovered energy will be calculated.

Convenient Storage

Transport casing holding up to 2 transducer pairs, T-Sensors, belt and metal stretchers, power bank, cables, charger and documentation



Accessories



Temperature sensor with metal stretcher

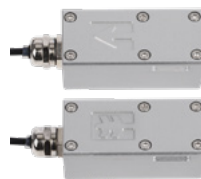

UTH-S transducer for higher temperature applications



Belt stretcher for temporary installation



Transducer mounting fixture simplify the flow transducer installation

Applications

- Cooling / Heating / Process Water
- Purified Water Measurement
- Fuel, Oils, Petroleum Products
- Water Treatment
- Food / Beverage
- HVAC / Energy System Audits
- Sanitary flow metering
- Hydraulic System Test
- Pharmaceutical Industry

Mobile Power

S461 powered by power bank with connection cable KA66A5530154

Note: power bank must be sourced locally due to shipping restrictions [USB-C, 20 V, min. 100 mA]





Technical Data

Measurement

Flow

Accuracy	1.0 % o. RDG \pm 0.01 m/s
Selectable units	Metric: m/s, m ³ /h, m ³ /min, l/min, m ³ Imperial: ft/min, cfm, cfs, USG/min, IG/min, bbl/min
Measuring range	0 ... 12 m/s
Repeatability	0.5 % o.RDG
Transducer	Ultrasonic transducer
Sampling rate	5 samples / sec
Response time (t90)	0.1 sec

Consumption

Selectable units	Metric: m ³ , l Imperial: cf, IG, UG, bbl
------------------	---

Temperature

Accuracy	0.5 °C
Selectable units	Metric: °C. Imperial: °F
Measuring range	-40 ... +130 °C
Sensor	Pt1000

Energy Flow

Selectable units	Metric: GJ/h, kJ/h, kcal/h Imperial: MBtu/h, Btu/h
------------------	---

Energy

Selectable units	Metric: GJ, kJ, kcal, kWh, MWh Imperial: Mbtu, Btu
------------------	---

Signal / Interface & Supply

Analog output (Option)

Signal	4 ... 20 mA (4-wire), isolated
Scaling	0 ... max flow, freely adjustable
Load	max. 250 Ohm
Update rate	100 ms

Pulse output (Option)

Signal	Switch output, normally open, nominal value: 24 VDC/0.5 A
Scaling	1 pulse per consumption unit (selectable)

Fieldbus

Protocol	Modbus/RTU (Standard) Modbus/TCP and PoE (Option)
----------	--

Supply

Voltage supply	20 ... 28 VDC
Current consumption	150 mA @ 24 VDC

General data

Configuration

Wireless	S4C-US App for mobile phones
----------	------------------------------

Display

Size/Resolution	2.4" color (640 x 480) graphic display, 1 touch button
-----------------	--

Data Logger

Storage	8 Mio. values
---------	---------------

Material

Main Casing	PC + ABS
Transducer	UT-S: Industrial synthetic plastics UTH-S: Aluminum

Miscellaneous

Electrical connection	2 x M12 D code (4 pole): transducer 2 x M12 (5 pole): Signals/Supply. (8-pole x-coded) for TCP 2 x M8 (4 pole): Pt1000 (Energy Meter Version)
-----------------------	--

Protection class	Main casing: IP65. Transducer: IP68
------------------	-------------------------------------

Approvals	CE, RoHS, FCC
-----------	---------------

Dimensions	Main unit: 124 x 102 x 70 mm UT-S Transducer: 64 x 30 x 27 mm UTH-S Transducer: 68 x 34 x 34 mm
------------	---

Weight	1.2 kg
--------	--------

Operating conditions

Fluids	All acoustically conductive liquids with less than 10 % gaseous
--------	---

Medium temperature	-40 ... +130 °C
--------------------	-----------------

Ambient temperature	Main unit: 0 ... +50 °C UT-S Transducer: 0 ... +80 °C UTH-S Transducer: -40 ... +130 °C
---------------------	---

Ambient humidity	< 99 % rH
------------------	-----------

Storage temperature	-30 ... 70 °C
---------------------	---------------

Transport temperature	-30 ... 70 °C
-----------------------	---------------

Pipe sizes	DN40 ... DN1200
------------	-----------------

Flow Ranges

DN	DO	Max flow		
		l/min	m ³ /h	cfm
40	48	905	54	32
50	60	1,414	85	50
65	76	2,389	143	84
80	88	3,619	217	128
100	114	5,655	339	200
125	139	8,835	530	312
150	165	12,723	763	449
200	219	22,618	1,357	799
250	273	35,341	2,121	1,248
300	323	50,891	3,054	1,797
500	508	141,365	8,482	4,992
1000	1016	565,458	33,929	19,970
1200	1219	814,260	48,858	28,756

Remarks: DN: nominal inner diameter
DO: outer diameter (depends on standard and material)



Ordering

Please use the following tables to assist in placing your order with our sales staff.

S461 Ultrasonic Flow Meter for Liquids (Clamp-On)

Order No.	Description
KA66D6954610	S461 Ultrasonic Flow Meter for Liquids main unit, USB, data logger and display
KA66D6954611	S461 Ultrasonic Flow & Energy Meter for Liquids main unit, USB, data logger, display and 2 additional M8 temperature inputs

Main Unit Mounting Plate

KA66000A4603	Pipe/Wall mounting plate (for pipe mounting please order metal stretcher separately)
KA66000A4604	35 mm DIN rail mounting plate
KA66000A4602	No mounting

Output Options

	Modbus/RTU
KA66000A4606	Modbus/RTU + 4 ... 20 mA, Pulse / Alarm
KA66000A4607	Modbus/RTU + Modbus/TCP

S461 Ultrasonic transducers for flow meter

KA66S6954610	UT-S, Ultrasonic transducer pair, DN40 ... DN1200, 5 m cable, M12 connector, 0 ... +80 °C, IP68 (includes coupling agent)
KA66S6954611	UTH-S, Ultrasonic transducer pair, DN40 ... DN1200, 5 m cable, M12 connector, -40 ... +130 °C, IP68 (includes coupling agent)

S461 Temperature Sensors for Energy Meter

	No further sensor
KA66S6934610	Temperature sensor pair, 5 m cable, M8 connector -40 ... +130 °C, IP42, for S461 energy meter only

Sensor Installation

	Metal stretcher for transducer and main unit installation on pipes
KA66A6954601	DN40 ... DN65 (2 pieces)
KA66A6954602	DN80 ... DN100 (2 pieces)
KA66A6954603	DN125 ... DN150 (2 pieces)
KA66A6954604	DN200 ... DN300 (2 pieces)
KA66A6954605	DN350 ... DN500 (2 pieces)
KA66A6954608	Belt stretcher for temporary sensor installations (portable unit), DN40 ... DN500 (2 pieces)

Example 1: S461 ultrasonic flow & energy meter, main unit wall mounting, output Modbus/RTU and 4 ... 20mA, ultrasonic transducer -40 ... 130 °C, transducer installation DN 200: KA66D6954611, KA66000A4603, KA66000A4606, KA66S6954611, KA66S6934610, KA66A6954604

Example 2: S461 portable ultrasonic flow meter, ultrasonic transducer 0 ... 80 °C, transport casing, cable to powerbank: KA66D6954610, KA66S6954610, KA66A5544625, KA66A5530154

Useful Accessories

Order No.	Description
KA66A5530104	Sensor cable, 5 m, M12 connector, open wires, AWG 24 (0.2 mm ²)
KA66A5530105	Sensor cable, 10 m, M12 connector, open wires, AWG 24 (0.2 mm ²)
KA66A5540107	Mains unit 100 ... 240 VAC/24 VDC, 0.5 A for SUTO sensors, 1,5 m cable, M12 connector
KA66A5544625	Transport casing S461 dimensions: 560 x 450 x 160 mm (portable unit)
KA66A5530159	S461 flow transducer extension cable pair, 5 m, M12, 4-pole male/female
KA66A5530163	S461 temperature sensor extension cable pair, 5 m, M8, 4-pole male/female
KA66A6954610	Coupling agent for sensor installation, 65 g
KA66A6954617	Transducer mounting fixture for (UT-S) ultrasonic flow transducer pair
KA66A6954618	Transducer mounting fixture for (UTH-S) high-temperature ultrasonic flow transducer pair
KA66A5530154	Cable to connect power bank, 1.8 m, USB-C connector for power bank, M12 connector

Calibration & Services

Order No.	Description
KA66R2004610	Calibration S461 together with transducer pair
KA66R2004613	Calibration temperature sensor S461



www.kompauto.com



sales@kompauto.com



S462



Compact Ultrasonic Flow Meter for Liquids

Clamp-on



CLAMP ON
No contact to medium



TRANSIT TIME CORRELATION TECHNIQUE



PORTABLE
Connectable to S551



LOCAL DISPLAY
For easy configuration and live values



STATIONARY
Connectable to S330 / S331 series



COMPACT DESIGN
Can be installed anywhere



Benefits

- ✔ Clamp on type, very easy installation
- ✔ No moving parts
- ✔ Can be installed on stainless steel pipe, carbon steel pipe, copper pipe or plastic pipe such as (PVC, PVDF, PPR, PPH, HDPE, etc.)
- ✔ Clean fluid measurements: water, sea water, others on request
- ✔ Available pipe sizes: DN20, DN25, DN32, DN40

Time-efficient Liquid Measurement

The S462 ultrasonic clamp on flow meter for liquids uses the proven transit-time correlation technique. The unit is simply clamped onto the pipe and will never come in contact with the fluid.

Available in pipe sizes from DN20 ... DN40 the S462 impresses with ease of installation and accurate flow readings. It comes with Modbus/RTU interface and 4 ... 20 mA output, which makes it easy connectable to any facility monitoring system.

Of course S462 clamp on ultrasonic flow meter also works with the SUTO displays and data loggers S330/331 and S551.

Dimensions (Mounting Bracket)

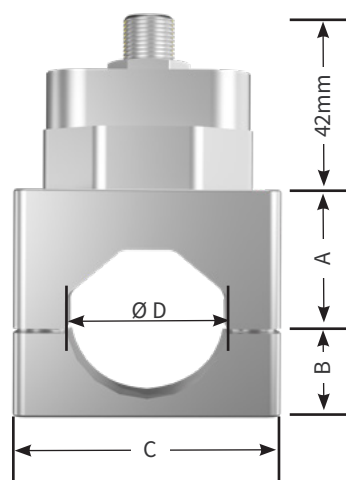

Dimensions (Main Unit)



Model size	A (mm)	B (mm)	C (mm)	D (mm)	
				min	max
DN20	26.5	15	58	25	28
DN25	30	18	58	32	35
DN32	33	22.5	68	38	45
DN40	38	27	78	48	54

Easy Installation



Placing the couplant pads before installation to the downside part of the main unit

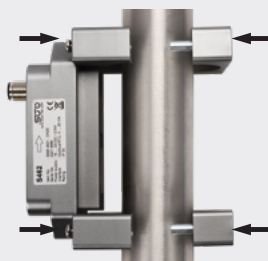

Easy clamp-on installation through mounting brackets



Vertical installation on a water pipe



Technical Data

Measurement

Flow

Accuracy	1.5 % o.RDG + 0.2 % FS (0.5 ... 5.0 m/s)
Selectable units	m ³ /h, l/min, GAL
Measuring range	see table below
Repeatability	0.80 % o.RDG
Sensor	Piezo ultrasonic transducer
Sampling rate	3 samples / sec
Turndown ratio	10:1
Response time (t90)	<2 sec

Consumption

Selectable units	m ³ , liter, GAL
------------------	-----------------------------

Reference conditions

Selectable conditions	20 °C 1000 mbar (ISO1217), 0 °C 1013 mbar (DIN1343) freely adjustable
-----------------------	---

Signal / Interface & Supply

Analog output

Signal	4 ... 20 mA
Scaling	0 ... max flow / adjustable
Load	<600R
Update rate	3/sec

Fieldbus

Protocol	Modbus/RTU
----------	------------

Supply

Voltage supply	20 ... 28 VDC
Current consumption	100 mA @ 24 VDC

General data

Configuration

Settings	via integrated keyboard
----------	-------------------------

Display

Integrated	OLED, 128 x 64 pixel (31 x 16 mm)
------------	-----------------------------------

Data Logger

Totalizer	Daily, monthly, yearly consumption
-----------	------------------------------------

Material

Housing	Aluminum alloy
Sensor	PEI
Display cover	PMMA
Key pad	F150

Miscellaneous

Dimensions	see dimension drawing
Electrical connection	1 x M12 (5 pole)
Protection class	IP65
Approvals	CE, RoHS, FCC
Weight	0.47 ... 0.60 kg (depends on model)

Operating conditions

Medium	Water, sea water, others on request
Medium quality	No solid particles, no air bubbles
Pipe material	Carbon steel, stainless steel, copper, PVC, PP, PU
Medium temperature	0 ... 50 °C
Ambient temperature	0 ... 50 °C
Ambient humidity	< 95 % rH
Storage temperature	-30 ... +70 °C
Transport temperature	-30 ... 70 °C
Pipe sizes	DN20, DN25, DN32, DN40

Model Depending Technical Data

	Model	DN20	DN25	DN32	DN40
Pipe size	Pipe OD (mm)	25 ... 28	32 ... 35	38 ... 45	48 ... 54
	Pipe ID (mm)	20	25	32	40
	NPS	3/4"	1"	1¼"	1½"
Flow Range	Min flow (l/min)	0.94	1.47	2.41	3.77
	Max flow (l/min)	94.2	147.2	241.2	377.0

Ordering

Please use the following tables to assist in placing your order with our sales staff.

S462 Compact Ultrasonic Flow Meter for Liquids (Clamp-On)

Order No.	Description
-----------	-------------

KA66S6954621	S462 Clamp On Ultrasonic Flow Meter, DN20 , including 2m cable and 4 couplant pads
KA66S6954622	S462 Clamp On Ultrasonic Flow Meter, DN25 , including 2m cable and 4 couplant pads
KA66S6954623	S462 Clamp On Ultrasonic Flow Meter, DN32 , including 2m cable and 4 couplant pads
KA66S6954624	S462 Clamp On Ultrasonic Flow Meter, DN40 , including 2m cable and 4 couplant pads

Accessories

Order No.	Description
-----------	-------------

KA66A6954620	Couplant pad, 4 pieces, 0 ... +80 °C
KA66A5540129	Transport casing S462 , can hold 4 units, battery pack, 2 m cable, 5 m cable, cal cert, IM, dimensions: 465 x 365 x 185 mm
KA66A5540107	Plug-in power supply, 100 ... 240 VAC / 24 VDC, 0.5 A , 2 m cable M12 connector. Recommended for portable unit
KA66A5530156	Cable to connect external power bank, 1.8 m, USB-C connector for power bank, M12 connector 90 degree for S462
KA66R2004620	Calibration S462
KA66000A4615	Sensor cable length extension (please inquire)
KA66A5543310	RS-485 splitter T, with 3 x M12 connectors to connect RS-485 devices to a bus



Portable set in transport casing. Can hold up to 4 units with battery pack, cables, charger and documentation



S462 powered by external power bank with connection cable KA66A5530156

Note: Power bank must be sourced locally due to shipping restrictions [USB-C, 20 V, min. 80 mA]



www.kompauto.com



sales@kompauto.com



S211 / S215 / S220



Dew Point Transmitters



S211

-60 ... +20 °C Td

FOR ADSORPTION DRYERS

S215

-20 ... +50 °C Td

FOR FRIDGE DRYERS

S220

-100 ... +20 °C Td

FOR HIGH-TECH APPLICATIONS



SIGNAL OUTPUT
4 ... 20 mA
Modbus/RTU



DISPLAY OPTION
For on-site values



COMPACT DESIGN
Makes it easy to fit into the application



PRESSURE SENSOR
integrated as option



AIR QUALITY
Monitors humidity



PRECISE MEASUREMENT
± 2 °C Td
Accuracy



Benefits

- ✓ Compact size makes them ideal for dryer installations
- ✓ Optional display for on-site values. Display can be rotated by 340 ° to fit your needs
- ✓ User friendly signal outputs to connect to process controls or monitoring systems
- ✓ IP65 casing provides robust protection
- ✓ Low maintenance costs due to stable and reliable measurements which increase calibration intervals
- ✓ Measured values available in several units: °C Td • g/m³ • mg/m³ • ppmv • g/kg (@ reference pressure) • % rH and more, please ask our support for other measurement units

1 Reliable Measurement

SUTO can rely on a 20+ years experience in developing dew point sensors used in compressed air systems and pressurized gases. During that period of time, the engineers have continued to develop new measurement methods and even developed own sensor elements for our innovative dew point meters.

2 Various Output Signal

The Dew Point Meters are perfectly suited to be integrated into process controls or high-level monitoring systems. Various output options are offered for a seamless integration:

- 4 ... 20 mA 2-wire + SDI
- 4 ... 20 mA 3-wire + SDI
- 4 ... 20 mA 3-wire + Modbus/ RTU

3 Robust Materials

The main body is made from high class aluminum alloy with a soft finish. The process connection is a 1.4301 (SUS 304) stainless steel connection, made to last forever.

Top cover made from aluminum at the same quality as the main body. The optional display cover is made from robust Polycarbonate with ABS reinforcement to withstand the rough environment.

4 Display Option

The OLED display directly mounted on the device provides on-site real time values. The display can be easily rotated by 340 ° to fit your application.



5 S220 with unique QCM Sensor

Our QCM sensor is the result of years of high-tech research and development. The sensor was especially designed for low dew point applications where other sensor types fail.

The combination of QCM and the well known Polymer sensor makes the S220 the worlds first model to measure accurate over the whole range, from -100 °C Td up to +20 °C Td by switching automatically between the two sensor elements as needed.



Measurement Ranges and Applications

Model	S211	S215	S220
Dew point	-60 ... +20 °C Td	-20 ... +50 °C Td	-100 ... +20 °C Td
Temperature	-30 ... +70 °C	-30 ... +70 °C	-30 ... +70 °C
Pressure	0 ... 1.6 MPa	0 ... 1.6 MPa	0 ... 1.6 MPa
Application	In desiccant dryers	In fridge dryers	In high tech requirements and conditions

Modbus Sensor Network with S331

The Modbus/RTU bus allows to connect several devices to a single bus line via Daisy-Chain. For example up to 16 devices to a S331. The S331 is a very powerful yet cost effective new data logger and display solution.

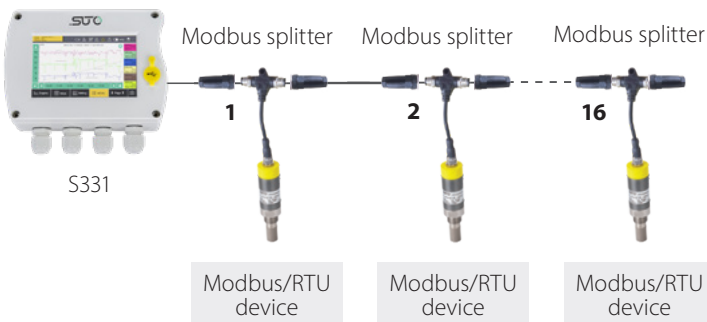

Dimensions

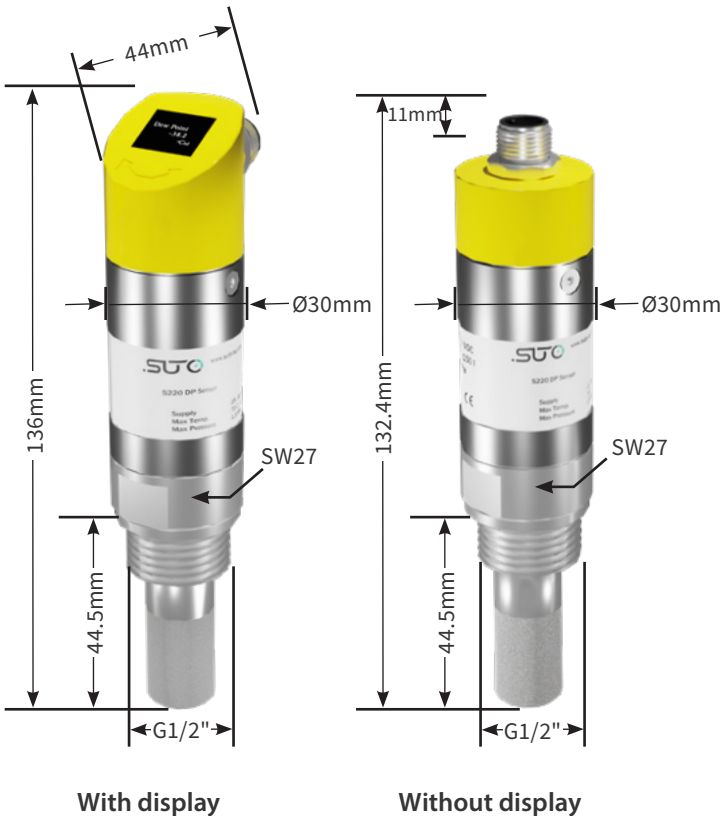

Exchange Service

No Downtime anymore!

The exchange calibration service eliminates down time and enables users to have a seamless record of their dew point measurements.

The user receives in advance a calibrated instrument with calibration certificate and the same instrument settings. The onsite instrument is then switched against the calibrated one and returned to the supplier.

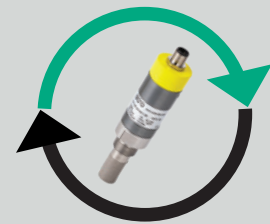

SUTO | Exchange Service

S220 with unique triple sensor solution

With the S220, SUTO is combining three sensors into a single measurement unit, making it unique and the most advanced sensor available on the market, with a full range of -100 ... +20 °C Td.

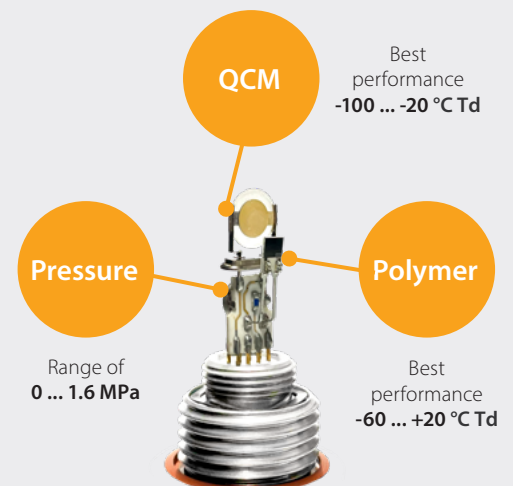



Technical Data

Specifications

Model	S211	S215	S220
Measurement Range	Dew point -60 ... +20 °C Td Temperature -30 ... +70 °C Pressure 0 ... 1.6 MPa	Dew point -20 ... +50 °C Td Temperature -30 ... +70 °C Pressure 0 ... 1.6 MPa	Dew point -100 ... +20 °C Td Temperature -30 ... +70 °C Pressure 0 ... 1.6 MPa
Dew point sensor	Polymer	Polymer	Polymer + QCM
Operating Pressure	-0.1 ... 1.6 MPa -0.1 ... 35.0 MPa optional	-0.1 ... 1.6 MPa -0.1 ... 35.0 MPa optional	-0.1 ... 1.6 MPa
Response time (t90)@4 l/min	0 °C Td -60 °C Td ≤ 280 sec -60 °C Td 0 °C Td ≤ 65 sec	0 °C Td -20 °C Td ≤ 50 sec -20 °C Td 0 °C Td ≤ 35 sec	0 °C Td -80 °C Td ≤ 420 sec -80 °C Td 0 °C Td ≤ 90 sec
Accuracy	Dew point +/- 1 °C Td (0 ... 20 °C Td) +/- 2 °C Td (-70 ... 0 / +20 ... +50 °C Td) +/- 3 °C Td (-100 ... -70 °C Td) Temperature +/- 0.3 °C Pressure 0.5 % FS		
Process connection	G 1/2" (ISO 228/1), stainless steel 1.4301 (SUS 304)		
Operating conditions	Medium Temp.: -30 ... +70 °C / Ambient Temp.: 0 ... +50 °C / Ambient Humidity: 0 ... 100 % rH		
Materials	Casing: Aluminum alloy / Process thread: Stainless steel 1.4301 (SUS 304) / Display cover: PC + ABS		
Classification / Approval	IP65 / CE		
Sensor protection	Sinter filter (stainless steel)		
Transport & Storage	Transport Temperature: -30 ... + 70 °C / Storage Temperature: -20 ... + 50 °C		
Weight	180 g		
Measured gases (Medium)	Air, Argon, O ₂ , N ₂ , CO ₂ *		
Output Signal	4 ... 20 mA 2-wire + SDI, 4 ... 20 mA 3-wire + SDI, 4 ... 20 mA 3-wire + Modbus/RTU		
Sensor types	Temperature sensor: Pt100 / Pressure sensor: Piezo resistive type		
Display option	0.66" OLED display, indicates the measured value and unit		
Supply Voltage	15 ... 30 VDC		

* CO₂ medium:

If the S211 is used in CO₂ the range is limited to -40 °C Td

The S211 and S220 must be set to CO₂ ex works or by using the S4C-DP Service Software + Service Kit (please state at the order if S211 and S220 will be used in CO₂)

Accessories



Measuring chamber for easy installation through quick coupling



By-pass measuring chamber with 6 mm hose connections as in- and outlet



High pressure measuring chamber for applications up to 35.0 MPa



M12 Sensor cable with open ends 5 m or 10 m



Ordering

Please use the following tables to assist in placing your order with our sales staff.

	2-wire Analog & SDI output	3-wire Analog & SDI output	3-wire Analog & Modbus/RTU* ³ output	3-wire Analog & Modbus/RTU* ³ output With Pressure Sensor
Transmitter Model and Range	Article No.	Article No.	Article No.	Article No.
S215 Dew Point Transmitter -20 ... +50 °C Td	KA66S6991215	KA66S6992215	KA66S6993215	KA66S6994215
S211 Dew Point Transmitter -60 ... +20 °C Td	KA66S6991211	KA66S6992211	KA66S6993211	KA66S6994211
S220 Dew Point Transmitter -100 ... +20 °C Td	KA66S6991220	KA66S6992220	KA66S6993220	KA66S6994220
Options				
Operating Pressure 0 ... 1.6 MPa (Standard)	KA66000A1380	-KA66000A1380	KA66000A1380	KA66000A1380
Operating Pressure 0 ... 35.0 MPa	KA66000A1381* ¹	KA66000A1381* ¹	KA66000A1381* ¹	N/A* ²
Without Display (Standard)	KA66000A1389	KA66000A1389	KA66000A1389	KA66000A1389
With OLED Display	N/A* ²	KA66000A1387	KA66000A1388	KA66000A1388

*¹ KA66000A1381: The high pressure option is only available for the models S215 and S211. The S220 can not be used in pressure applications > 1.6 MPa

*² N/A: This option is not available for these models

*³ Standard Modbus/RTU Settings are Slave Address: last two digits of serial number / Com. Settings: 19200 baud, 8/N/1

Order Example

Code: S211 Dew point Transmitter, -60 ... +20 °C Td,
KA66S6993211 3-wire Analog & Modbus/RTU output, Operating
KA66000A1388 Pressure 0 ... 1.6 MPa, with OLED Display

Output Unit

The dew point Transmitter is available with different measurement units for dew point, humidity, temperature and pressure. Standard is: **Dew point = °C Td / Temperature = °C / Pressure = bar**
If you would like to have a different unit as output, please specify it at the order or use the optional Service Kit with the Service Software to change the output unit. For example pressure in PSI or humidity in ppmv.

Accessories

Article No.	Description
KA66A6993491	Measuring chamber with quick connector, up to 1.6 MPa, 2 l/min purge @ 0.8 MPa
KA66A6993493	Measuring chamber by-pass, up to 1.6 MPa, 6 mm hose connection as in- and outlet
KA66A6993590	High pressure measuring chamber, up to 35.0 MPa, G 1/4" inner thread process connection
KA66A5530104	Sensor cable, 5 m with M12 connector, open wires, AWG 24 (0.2 mm ²)
KA66A5530105	Sensor cable, 10 m with M12 connector, open wires, AWG 24 (0.2 mm ²)

Calibration

Article No.	Description
KA66R6993396	Re-calibration dew point transmitter, incl. certificate of calibration

Similar to illustration and pictures / MODBUS® Bluetooth® word mark and logos
Registered trademark of the Modbus Organization, Hopkinton, USA



www.kompauto.com



sales@kompauto.com



S230 / S231



Dew Point Transmitters for Ex Applications

S230	-100 ... +20 °C Td
S231	-50 ... +50 °C Td



IECE X AND GB EX APPROVAL



PRECISE MEASUREMENT
Unique QCM sensor technology



LOW DEW POINT
Measures down to -100 °C Td



DUAL SENSOR SYSTEM
High precision over the whole range



Benefits

- ✓ Dew Point Transmitter made for Ex-Applications (IECEx, GB3836 Ex)
- ✓ Robust enclosure for the use rough industrial environments
- ✓ Dual sensor technology for the highest accuracy over the full range of -100 ... +20 °C Td
- ✓ G1/2" Stainless steel process connection
- ✓ 4 ... 20 mA analog and Modbus/RTU digital outputs for highest flexibility

Reliable dew point monitoring

The SUTO S230 / S231 dew point sensors provide reliable, long term stable dew point monitoring in industrial or hazardous applications. SUTO's unique dual sensor technology optimizes sensor sensitivity and accuracy by automatically selecting the ideal sensor type for the situation.

The S230 / S231 comes ready to use and simple to install with your choice of 4-20mA or Modbus/RTU (RS485) outputs. If required, parameters can quickly and easily be configured through the SUTO service software.

Cable connection



Screw terminals with signal labels inside the connection chamber

Accessories



Measuring chamber with inlet / outlet valve and compression fitting for gas supply

Dimensions

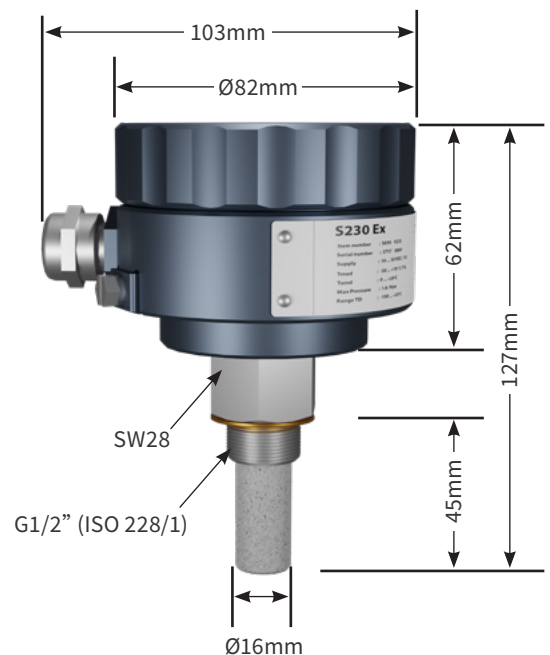



Technical Data

Measurement

Dew Point

Accuracy	± 1 °C Td (0 ... 20 °C Td) ± 2 °C Td (-60 ... 0 °C Td) ± 3 °C (-100 ... -60 °C Td)
Selectable units	°C, °F, bar(g), MPa(g), psi(g), % rH, g/m ³ , mg/m ³ , G/m ³ atm., mg/m ³ atm., ppm(v), g/kg, °C Td atm.
Measuring range (model depending)	S230: -100 ... +20 °C Td S231: -50 ... +20 °C Td
Sensor	Polymer + QCM
Response time t90 (@ 4l/min)	-20 °C Td -> -60 °C Td = < 240 sec -60 °C Td -> -20 °C Td = < 30 sec

Temperature

Accuracy	0.3 °C
Measuring range	-30 ... +70 °C
Sensor	NTC

Reference conditions

Selectable conditions	Pressure Dew Point, Atmospheric Dew Point
-----------------------	--

Signal / Interface & Supply

Analog output

Signal	4 ... 20 mA (isolated) Modbus/RTU
Scaling	S230: 4 mA = -100 °C Td; 20 mA = +20 °C Td S231: 4 mA = -50 °C Td; 20 mA = +20 °C Td
Load	250R
Update rate	3/sec

Fieldbus

Protocol	Modbus/RTU
Update rate	1/sec

Supply

Voltage supply	15 ... 30 VDC
Current consumption	40 mA @ 24 VDC

General data

Configuration

PC Software	S4C-DP Application
-------------	--------------------

Material

Process connection	Stainless steel 1.4301 (SUS 304)
Housing	Aluminium alloy
Sensor	Stainless steel 1.4301 (SUS 304)
Metal parts	Sinter Filter (stainless steel)

Miscellaneous

Electrical connection	Screw terminals
Protection class	IP65
Approvals	Ex db[ib] IIC T4 Gb, CE
Process connection	G 1/2" thread (ISO 228/1)
Weight	728 g

Operating conditions

Medium	Air, Argon, O ₂ , N ₂ , CO ₂ *
Medium quality	ISO 8573-1: 4.6.3 or better
Medium temperature	0 ... +50 °C
Medium humidity	≤ 20 °C Td
Operating pressure (model depending)	-0.1 ... 1.6 MPa (S230) -0.1 ... 35 MPa (S231)
Ambient temperature	0 ... +50 °C
Ambient humidity	0 ... 100 % rH
Storage temperature	-20 ... +50 °C
Transport temperature	-30 ... +70 °C

Stated accuracy under following conditions:

- Ambient temperature 23 °C ±3 °C
- Process temperature 23 °C ±3 °C
- Ambient humidity < 95 %, no condensation
- Airflow > 2 l/min at sensor tip



Ordering

Please use the following tables to assist in placing your order with our sales staff.

S230 Dew Point Transmitter (-100 ... +20 °C Td)

Article No.	Description
KA66S6990230	S230 Dew Point Transmitter, -100 ... +20 °C Td, G 1/2" thread, 1.6 MPa, 1 x 4 ... 20 mA, RS-485 (Modbus)
KA66000A1481	Ex option IECEx (to be ordered for hazardous environment)
KA66000A1482	Ex option GB3836 (to be ordered for hazardous environment)
KA66000A1483	No Ex option

S231 Dew Point Transmitter (-50 ... +20 °C Td)

Article No.	Description
KA66S6990231	S231 Dew Point Transmitter, -50 ... +20 °C Td, G 1/2" thread, 35 MPa, 1 x 4 ... 20 mA, RS-485 (Modbus)
KA66000A1481	Ex option IECEx (to be ordered for hazardous environment)
KA66000A1482	Ex option GB3836 (to be ordered for hazardous environment)
KA66000A1483	No Ex option

Accessories

Article No.	Description
KA66A5542301	Measuring chamber with inlet / outlet valve and compression fittings for gas supply, 1.6 MPa
KA66A5542302	Measuring chamber with insertion type sampling tubes (for applications where purge losses are not acceptable), 1.6 MPa
KA66A6993491	Measuring chamber with quick connector, up to 1.5 MPa, 2 l/min purge @ 0.8 MPa
KA66A6993493	Measuring chamber by-pass, up to 1.5 MPa, 6 mm hose connection as in- and outlet



www.kompauto.com



sales@kompauto.com



S305



Dew Point Monitor

Opt. 1

-50 ... +20 °C Td

Opt. 2

-20 ... +50 °C Td



PLUG & PLAY

Simply connect your compressed air



DEW POINT MEASUREMENT

-50 ... +50 °C Td depending on the model



PRECISE MEASUREMENT

± 2 °C Td accuracy



ALARM INDICATION

With internal relays or alarm units



Benefits

- ✓ Plug & Play solution, no need for complicated setup and installation
- ✓ 6 mm hose connection with quick coupling for most convenient installation
- ✓ Two ranges available:
-20 ... +50 °C Td for fridge driers
-50 ... +20 °C Td for desiccant driers
- ✓ Wall mountable housing with a big display and optional alarm unit
- ✓ 4 ... 20 mA output to connect it to a PLC or BMS system
- ✓ Easy alarms set up for pre- and main alarm



Refrigeration dryers are the most commonly used dryer type in compressed air system around the world. If the required drying is not achieved, the impact of wet air can be serious: Rust in the pipes, failures of machines, and a negative impact on product quality.

SUTO offers with the S305 a measuring device for dew point monitoring that kicks in alarm indications when drying values are not within the desired range.

2 Models

-50 ... +20 °C Td and -20 ... +50 °C Td

1 Dew Point Sensor

Reliable polymer dew point sensor with integrated measuring chamber for accurate readings and fast response time

2 Robobust Casing

The entire measuring unit is integrated together with the display in a rugged housing (IP65)

3 Power Supply

100 ... 240 VAC or 24 VDC

4 Output

4 ... 20 mA output to PLC or SCADA system

5 Connection

The connection to the compressed air network is via a 6-mm quick connect and corresponding connecting hose.





Dimensions



Pre- and Main-Alarm programmable

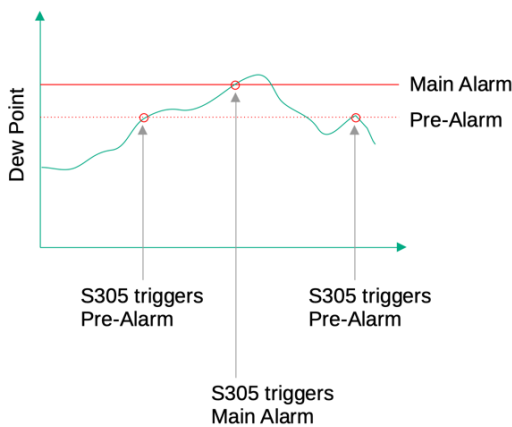

Two alarm levels can be programmed (pre and main alarm), serving an optical indications or separate relay outputs.

Exchange Service

No Downtime anymore!

The exchange calibration service eliminates down time and enables users to have a seamless record of their dew point measurements.

The user receives in advance a calibrated sensor unit with calibration certificate and the same sensor settings. The onsite sensor is then switched against the calibrated one and returned to the supplier.

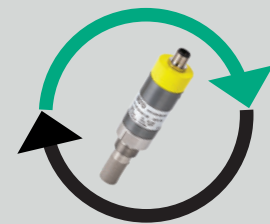

.STO | Exchange Service

Installation

S305 is designed to be Plug & Play. There is no need for complicated setup or configuration. Simply connect your compressed air and start measuring.

Optional Alarm Unit

Wall mounted housing with a big display for dew point, temperature and humidity. The optional alarm unit can be wall mounted or mounted directly on the housing. The 360° visible LED and the alarm buzzer indicate alarms reliably.





Technical Data

Measurement

Dew Point

Accuracy	±2 °C Td
Selectable units	°C, °F
Measuring range (model depending)	-50 ... +20 °C Td -20 ... +50 °C Td
Sensor	Polymer
Response time t90 (@ 4l/min)	-50 °C Td -> -20 °C Td = 20 sec 0 °C Td -> -40 °C Td = 120 sec

Temperature

Accuracy	0.3 °C
Measuring range	-30 ... +70 °C
Sensor	NTC

Reference conditions

Selectable conditions	Pressure Dew Point
-----------------------	--------------------

Signal / Interface & Supply

Analog output

Signal	4 ... 20 mA 3-Wire
Scaling	-50 ... +20 °C Td or -20 ... +50 °C Td
Load	250R
Update rate	3 / sec

Supply

Voltage supply (model depending)	100 ... 240 VAC ; 50/60 Hz 24 VDC
Current consumption (model depending)	40 mA @ 220 VAC 120 mA @ 24 VDC

General data

Configuration

PC Software	S4C-Display Software
Others	Instrument comes pre-configured Plug & Play

Display

Integrated	LCD Display, indicates values and alarms
------------	--

Material

Process connection	Stainless steel 1.4301 (SUS 304)
Housing	ABS, Aluminium alloy
Sensor	Polymer
Metal parts	Sinter Filter (stainless steel)

Miscellaneous

Electrical connection	Screw terminals
Protection class	IP65
Approvals	CE
Process connection	6 mm quick connector
Weight	520 g

Operating conditions

Medium	Non-corrosive gases
Medium quality	ISO 8573-1: 4.6.3 or better
Medium temperature	-30 ... +70 °C
Medium humidity	≤ 20 °C Td or ≤ 50 °C Td (model depending)
Operating pressure	0.3 ... 1.5 MPa
Ambient temperature	-10 ... +40 °C
Ambient humidity	0 ... 100 % rH
Storage temperature	0 ... +40 °C
Transport temperature	-30 ... +70 °C

Stated accuracy under following conditions:

- Ambient temp 23 °C ±3 °C, Process temp 23 °C ±3 °C
- Ambient humidity < 95 %, no condensation
- Airflow > 2 l/min at sensor tip

Ordering

Please use the following tables to assist in placing your order with our sales staff.

S305 Dew Point Monitor (-50 ... +20 °C Td / -20 ... +50 °C Td)

Article No.	Description
KA66D6993050	S305, Dew Point Monitor, -20 ... +50 °C Td, 6 mm quick connector, 15 bar, 1 x 4 ... 20 mA, 100 ... 240 VAC, 2 relay outputs
KA66D6993051	S305, Dew Point Monitor, -20 ... +50 °C Td, 6 mm quick connector, 15 bar, 1 x 4 ... 20 mA, 24 VDC, 2 relay outputs
KA66D6993052	S305, Dew Point Monitor, -50 ... +20 °C Td, 6 mm quick connector, 15 bar, 1 x 4 ... 20 mA, 100 ... 240 VAC, 2 relay outputs
KA66D6993053	S305, Dew Point Monitor, -50 ... +20 °C Td, 6 mm quick connector, 15 bar, 1 x 4 ... 20 mA, 24 VDC, 2 relay outputs

Accessories

Article No.	Description
KA66A5540024	Alarm unit, 100 ... 240 VAC, red light and buzzer alarm, wall mountable (unit is using the relay outputs of S305 to trigger the alarm)
KA66A5540025	Alarm unit, 100 ... 240 VAC, red light and buzzer alarm, mounted at S305 casing (unit is using the relay outputs of S305 to trigger the alarm)
KA66A5530106	Power cable with mains plug, 1.8 m



www.kompauto.com



sales@kompauto.com



S520



Portable Dew Point Meter



Opt. A

-100... +20 °C Td

Opt. B

-50... +50 °C Td



SMART DEVICE

Dew point prediction



TOUCH SCREEN

Intuitive user interface



PRESSURE SENSOR

Enables various humidity units

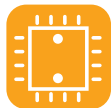

DATA LOGGER

Integrated mass storage



LOW DEW POINT

Measures down to -100 °C Td



CAMERA INTEGRATED

Pictures for better reports



PORTABLE UNIT

Handheld unit within a rugged case



DEW POINT AUDITS

Indication of class on display



Benefits

- ✓ Easy to use portable meter to measure dew point, temperature and pressure on site
- ✓ Sensor selection according to your needs (-100 ... +20 °C Td with pressure sensor / -50 ... +50 °C Td version)
- ✓ ISO 8573 class measurements with powerful ISO 8573-1 PDF reporting function
- ✓ Wireless printer for on-site reporting to easily perform audits
- ✓ Unique Measuring chamber with parking function supports fast response times
- ✓ Optional smart features: End value prediction, camera and measurement snapshot

1 Dew Point Value Prediction

The S520 offers a unique dew point end value prediction algorithm as a built-in technology.

Based on the dew point measurement curve our algorithm is able to predict the end value before actually reaching the end value.

This feature enables the user to predict the dew point end value in a minimum amount of time. It helps on-site engineers to save time and to perform faster dew point audits.

Smart Features

Dew point end value prediction is a part of the smart features. With the smart features option, users also get a 5 Megapixel camera and the snapshot function for quick measurement logging.

2 Measurement Snapshot

Take a quick measurement snapshot of the current measurement, add the customer information and easily create a printed report.

All can be done on the device via touchscreen input.

3 Measurement Chamber

The unique measuring chamber with integrated parking function enables users time efficient dew point measurements.

When the instrument is not used, the measuring chamber can be set to parking position. In this state, the sensor is exposed to a desiccant, which keeps the sensor well protected and dry.

When starting the next measurement, the sensor is pre-dried and has therefore an ultra-fast response time, perfect for air audits.

4 Unique SUTO Triple-Sensor

S520 is equipped with the SUTO QCM, the Polymer and an integrated Pressure sensor.

Our QCM sensor is the result of years of high-tech research and development. The sensor was especially designed for low dew point applications where other sensor types fail.

The combination of QCM and the well known Polymer sensor makes the S520 measure accurate over the whole range, from -100 °C Td up to +20 °C Td by switching automatically between the two sensor elements as needed. At the same time the line pressure is measured.





Application: Compressed Air Quality Monitoring On Site

The S520 Portable Dew Point Meter enables more accurate and frequent quality monitoring to operators. Throughout any given day, plant personnel can check the dew point throughout their system, using the S520's detailed metrics and portability to gather useful information from even the least accessible corners of their system.

With the S520, operators can make sure that their compressed air treatment system (air dryers, filters, and drains) is functioning at its absolute peak. If the S520 reveals heightened moisture levels at any point during the routine check, personnel can quickly locate and resolve the issue, reducing instances of clogged filters and dryer problems.

Optional Printer

Wireless printer used to print the measurement results on site. Perfect solution for quick audits.



Exchange Service

No Downtime anymore!

The exchange calibration service eliminates down time and enables users to have a seamless record of their dew point measurements.

The user receives in advance a calibrated instrument with calibration certificate and the same instrument settings. The onsite instrument is then switched against the calibrated one and returned to the supplier.

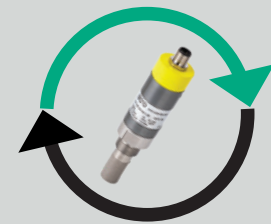

PDF Report Function according to ISO 8573-1

Create powerful PDF Reports on-site according to the ISO 8573-1 standard.

The reports are following the recommendations stated in the ISO 8573-1, additionally customer related data as well as service provider details can be entered on-screen, making it even easier to perform audits and to create meaningful reports.

PDF reports can be created from any recordings on the device and are copied on the fly to a connected USB drive.

The declared Pressure dew point in °C is stated as the measured dew point under actual conditions as well as referring to reference conditions at 20 °C/7 bar(g), as it is required by ISO 8573-1 standard. This is only possible, thanks to the integrated pressure sensor on the S520.

Air Purity Report
S520 Portable Dew Point Meter

Measurement device
Model: S520
Manufacturer: SUTO ITEC
Last calibration: 22. June.2022
Serial number: 1234 5678

Location information
Customer: Customer GmbH
Tester name: Max Mustermann
Measurement Location: Prod. Line 1
Measurement Point: Machine 1

Service provider
Company: SUTO ITEC GmbH
Phone: 0049 7634 504 88 00
Email: info@suto-itec.com

Target classes ISO 8573-1 (selected by user)
Humidity: 3

Measurement information
Measurement started: 14:56:00 22. August 2021
Measurement stopped: 15:26:00 22. August 2021
Measurement duration: 00:30:00

Measurement results
System / Measurement conditions
Medium Temperature [°C]: 31.0
Medium Pressure [bar]: 5.62
Gas Type: Air

Declared Pressure dew point in °C (referring to actual and reference conditions 20 °C; 7 bar(g)) ¹⁾			
Reference conditions	Limit value	Measured value	Evaluation
actual conditions	N.S. ²⁾	-24.6	N.S. ²⁾
20°C / 7 bar(g)	≤ -20.0	-22.7	passed

Measurement equipment
Pressure dew point: Polymer + QCM sensor Accuracy: ± 2 °C Range: -100... +20 °C Td

Approval
Signature Tester: _____ Signature Customer: _____ Place / Date: _____

Notes / Comments:

¹⁾ For further details, please check the calibration certificate.
²⁾ According to ISO 8573-1 the declared pressure dew point at 20°C and 7 bar(g) must be used for an ISO 8573-1 classification, all the pressure dew point at actual conditions shall be stated in the test report.



Technical Data

Measurement

Dew point

Accuracy	± 1 °C Td (0 ... 20°C Td) ± 2 °C Td (-70 ... 0 / +20 ... +50°C Td) ± 3 °C Td (-100 ... -70°C Td)
----------	--

Selectable units	%rH, °C Td, g/m ³ , mg/m ³ , g/m ³ atm., ,mg/m ³ atm. , ppmv, g/kg, °C Td atm.
------------------	---

Measuring range	Sensor A: -100 ... +20°C Td Sensor B: -50 ... +50°C Td
-----------------	---

Repeatability	0.5 °C
---------------	--------

Sensor	Sensor A: QCM + Polymer Sensor B: Polymer
--------	--

Pressure

Accuracy	0.5 % FS
----------	----------

Measuring range	0 ... 1.5 MPa (g)
-----------------	-------------------

Sensor	Piezo resistive sensor
--------	------------------------

Temperature

Accuracy	± 0.3 °C
----------	----------

Measuring range	-30 ... +50°C
-----------------	---------------

Sensor	PT 100
--------	--------

Interface & Supply

Supply

Power supply	USB charger: 5 V, 3 A Connector: USB-C
--------------	---

Operating time	8h
----------------	----

Data interface

Connection	USB
------------	-----

* At least 0.3 MPa(g) is needed for the measuring chamber supplied with the instrument. For low-pressure measurements below 0.3 MPa (g) choose the optional bypass measuring chamber KA66A6993501.

General data

Display

Integrated	3.5" color LCD touch screen
------------	-----------------------------

Data Logger

Storage	Integrated mass storage, 100 Million values
---------	---

Material

Housing	PC + ABS
---------	----------

Metal parts	Aluminium
-------------	-----------

Miscellaneous

Protection class	IP30
------------------	------

Approvals	CE
-----------	----

Weight	2.7 kg complete set in transport case
--------	---------------------------------------

Operating conditions

Medium	Air, N ₂ , O ₂ , Argon, CO ₂
--------	---

Note: The CO₂ measurements with the KA66000A1371 sensor are limited to -40 °C Td.

Medium temperature	-30 ... +50°C
--------------------	---------------

Medium humidity	0 ... 90 %, no condensation
-----------------	-----------------------------

Operating pressure	-0.1 ... 1.6 MPa (g)*
--------------------	-----------------------

Ambient temperature	0 ... +40°C
---------------------	-------------

Ambient humidity	0 ... 80% rH
------------------	--------------

Storage temperature	-20 ... +50 °C
---------------------	----------------



Ordering

Please use the following tables to assist in placing your order with our sales staff.

S520 Portable Dew Point Meter

Article No.	Description
	S520 Handheld Dew Point Meter with data logger
	<u>Including:</u>
KA66P6000520	<ul style="list-style-type: none"> Measuring chamber with parking function 1.5 m PTFE hose 6 mm with quick coupling, USB-OTG memory stick USB charger with USB-C cable Certificate of calibration Transport casing
Measuring range (Sensor unit)	
KA66000A1370	-100 ... +20 °C Td Standard range sensor unit, with integrated pressure sensor -0.1 ... 1.5 MPa
KA66000A1371	-50 ... +50 °C Td Economic range sensor unit, without integrated pressure sensor
Wireless printer	
KA66000A1374	Without printer
KA66000A1372	With wireless printer for measurement printouts on site
Smart feature	
KA66000A1375	Without smart features
KA66A5530106	With smart features (Measurement snapshot, Dew point end value prediction, Camera)

S520 Accessories

Article No.	Description
KA66A6993501	By-pass measuring chamber with parking function, 0 ... 1.0 MPa, 6 mm hose quick connector as in- and outlet
KA66A5540021	Paper rolls for wireless printer

Example: S520 Handheld Dew Point Meter with data logger, measuring chamber, incl. transport casing, -100 ... +20 °C Td Standard range sensor unit with pressure measurement, wireless printer, smart features

Article numbers:

KA66P6000520
 KA66000A1370
 KA66000A1372
 KA66A5530106

Scope of delivery

S520



Unique measuring/parking chamber for fast sensor response



The included transport case protects the instrument. At the same time it holds all accessories.



Memory stick



PTFE hose with quick connect



USB charger with USB-C cable



www.kompauto.com



sales@kompauto.com



S330/S331



Display and Data Logger



- S330** Display
- S331** Display & Data Logger

IIoT
IIOT SUPPORT
 Connection to S4M software

TOUCH SCREEN
 5" large color LCD

WEB SERVER
 Access from world wide

VERSATILE CONNECTION
 Up to 16 sensors inputs

TIGHT PROTECTION
 IP65

DATA LOGGER
 100 million values



Benefits

- ✓ Central unit of a compressed air monitoring system, collecting, recording and visualizing all measurement data
- ✓ High-resolution 5" color touch screen for easy operation and on-site data visualization
- ✓ Connect up to 16 Modbus/RTU sensors, 2 analog sensors and 2 SDI sensors to a single data logger
- ✓ Modbus/RTU and Modbus/TCP output always included for a seamless integration into existing monitoring and building management systems
- ✓ Alarm monitoring for all measurement channels with on-screen indication and 2 relay outputs

Plug and Play Data Logging – Process Visualization and Analysis

The S330/S331 Display and Data Logger provides an universal solution for displaying and recording all relevant parameter of a compressed air system, which includes flow, dew point, pressure, temperature, power consumption, compressor status, and so on.

The devices offer a powerful yet cost efficient data logger and display solution for optimal and reliable management and monitoring of your compressed air system.

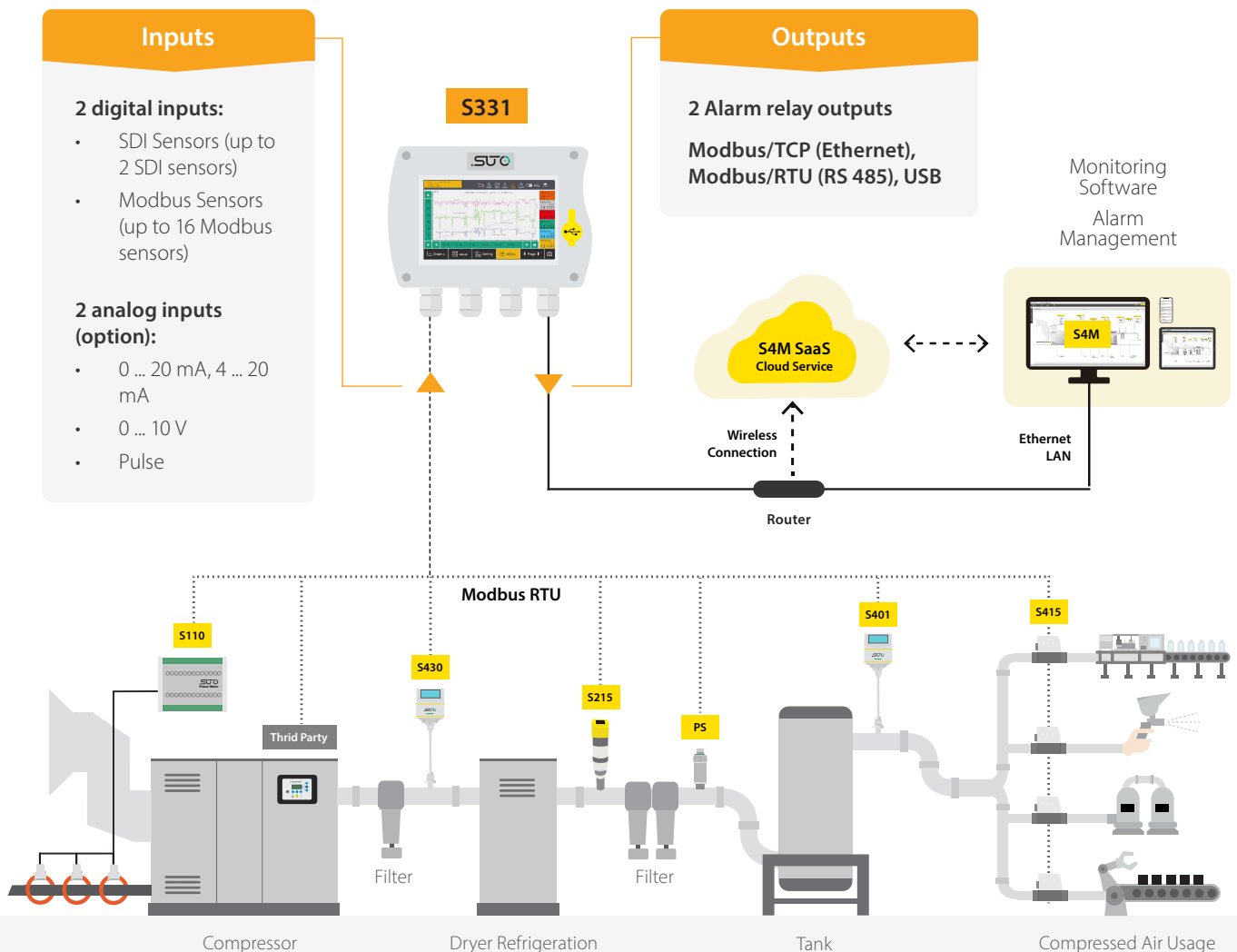



Applications

The S331 Display and Data Logger is used to gather and collect measurement data of various field devices. It acts as the central unit where all measurement data is safely stored and visualized. The digital communication outputs are not making it a display and data logger, but also a gateway to connect to IIoT services, as well as to connect it to modern software solutions



Available Installation Options



2 different wall mountable casings to fit customers needs.

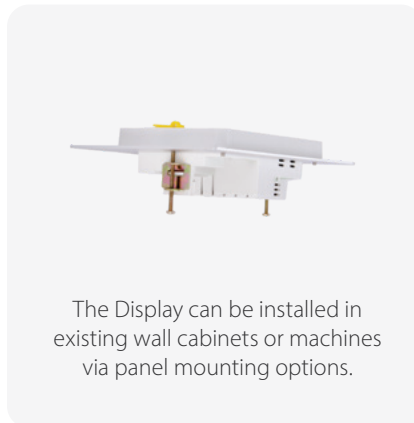

The Display can be installed in existing wall cabinets or machines via panel mounting options.

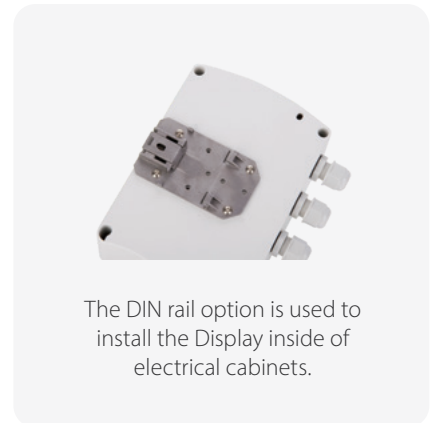

The DIN rail option is used to install the Display inside of electrical cabinets.

1 SUTO Modbus/RTU Sensor Input

The S330 / S331 includes digital inputs for SUTO SDI sensors and Modbus/RTU sensors. To connect the Modbus/RTU sensors properly on an RS 485 bus system, it's recommended to daisy-chain the sensors to one of the inputs. For this purpose, SUTO offers a RS 485 splitter to simplify the connection.

Through this method, users can add up to 16 sensors to the master input, making it most versatile and allowing to monitor whole plants with a single data logger. (Additional power supplies for field devices might be necessary)

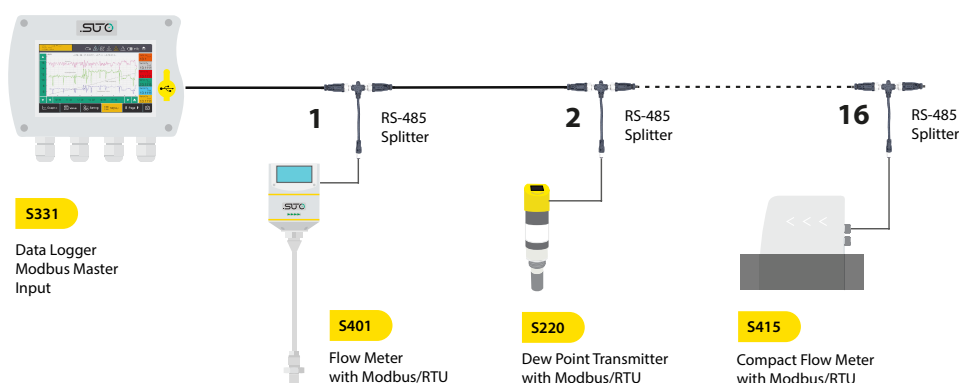



2 Analog Sensor Input

The S330 / S331 can be equipped with an analog input option, allowing to connect 0/4... 20 mA, 0...10 V and pulse signals from field sensors. If more analog sensors need to be connected, a Analog-Modbus/RTU converter module can be easily connected, allowing to connect additionally 8 analog sensors.

This makes the S330 / S331 most versatile and offers the possibility to connect existing field hardware and sensors seamlessly into the monitoring system.

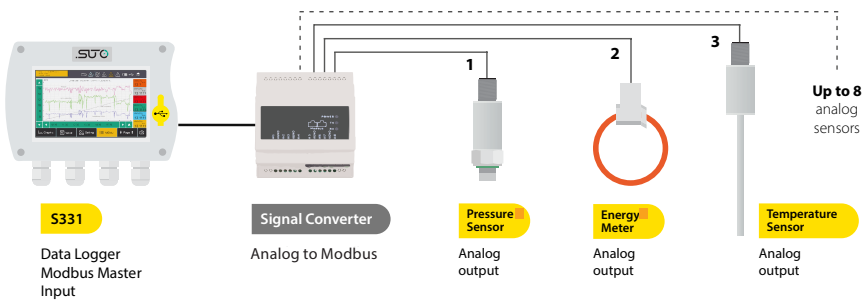

3 Third-Party Sensor and Field Device Support

By relying on the industry standard protocol Modbus/RTU, the S330 / S331 does support third-party sensors to be easily integrated into the monitoring system. Field devices can be easily set up using the configuration software, allowing to add third-party sensor within seconds.

Of course, all connected sensor data can be logged to the internal memory, used for virtual channel calculations and real-time values are forwarded to connected software and monitoring solutions.

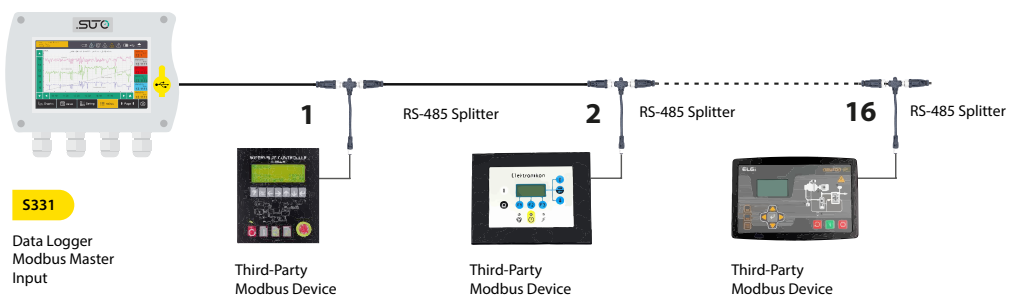

Data Analysis

Through the free SUTO S4A software recordings are downloaded to the PC via USB, LAN or wirelessly using the LTE/4G Modem. The basic analysis can be done in S4M.

For more sophisticated compressor analysis, the SUTO CAA software (incl. in S551) offers many advanced features such as:

- Performance statistics of compressors (efficiency, air delivery, load/unload cycles)
- Leakage analysis
- Report generation
- and more...

Comparisons with baseline measurements from last year or last month help to identify system changes.

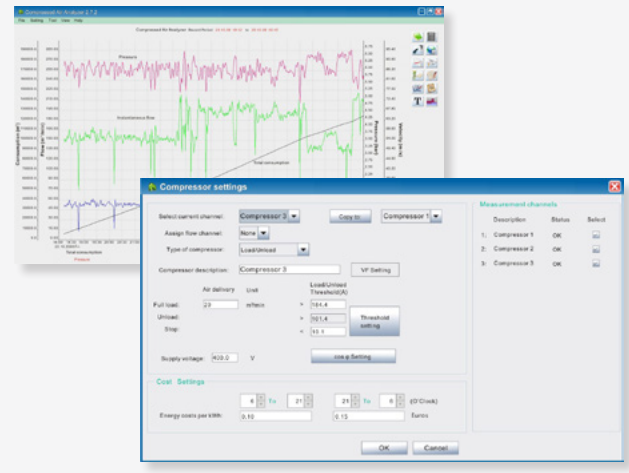



User Friendly Handling

The S330 / S331 comes with a high resolution 5" color touch screen interface making the operation as simple as possible.

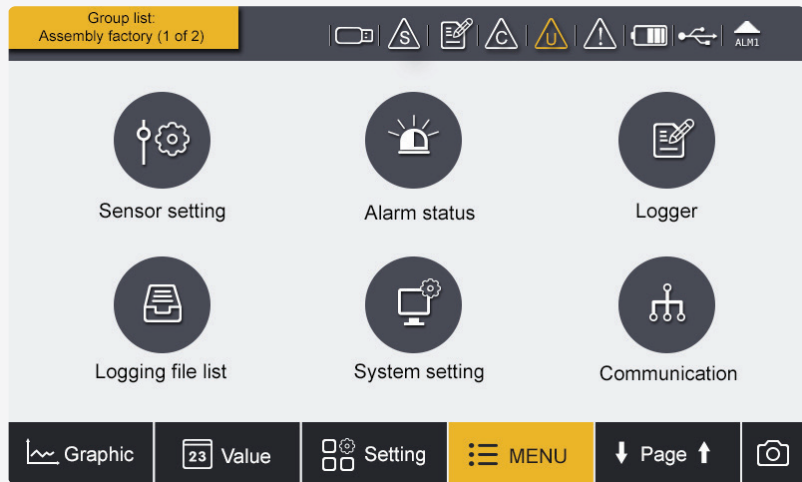

Sensor Data Overview

Up to 4 sensors can be viewed on one page and through page scrolling further sensors can be displayed.

This makes it easy to monitor different sensors at the same time.

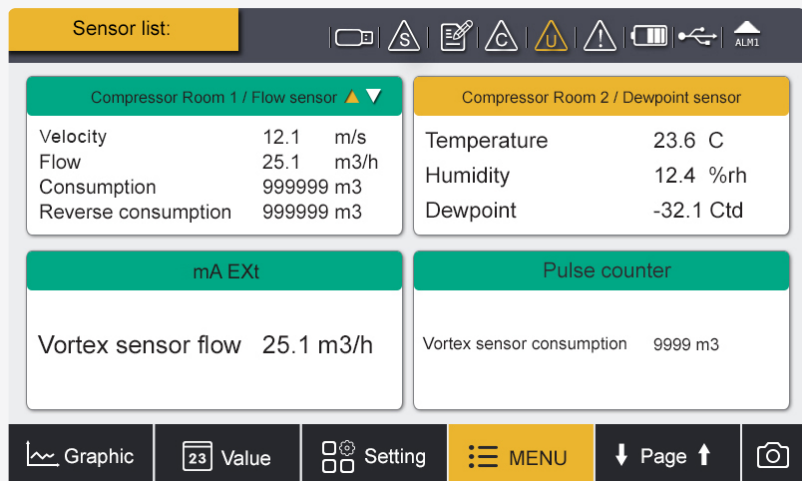

Graphic Charts for Quick Analysis

Select which channels you want to view or analyze and the built in graphic analyzer will help you identify problems immediately.

For detailed analysis we recommend using SUTO S4M software.

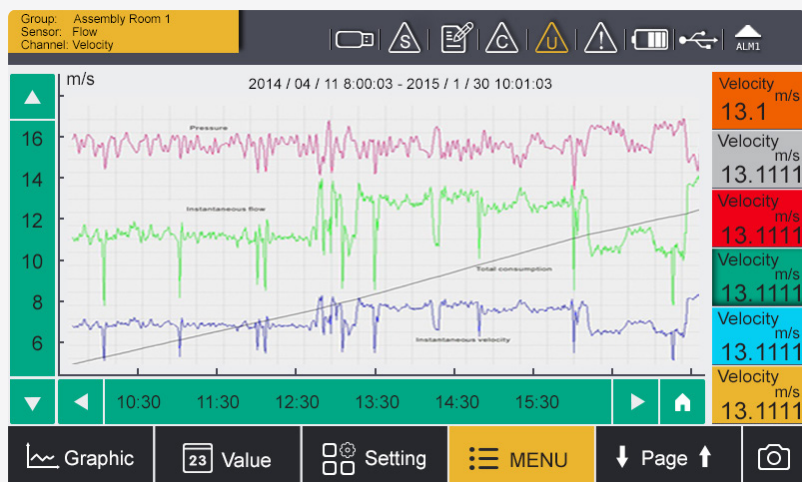



Technical Data

Signal / Interface & Supply

Data logger

Storage	Internal, 100 million values
Sampling rate	Optional $\geq 1s$, Max 59 mm: 59 ss

Input signals

Digital input	2 x SDI sensors 16 x RS-485 Modbus RTU Sensors 2 x 0 ... 20 mA / 4 ... 20 mA / 0 ... 10V
---------------	--

Analog input	2 x 0/4 ... 20 mA; 2 x 0 ... 10 V; 2 x pulse
--------------	--

Pulse input	100 Hz maximum; 28 V, 10 Ma
-------------	-----------------------------

Output signals

Analog / Pulse output	4 ... 20 mA signal and pulse signal of sensors can be looped through the display by using the connection board
-----------------------	--

Alarm output	2 relays, 230 VAC, 3 A, NC
--------------	----------------------------

Field bus Interface

Protocol	Modbus/TCP (Ethernet), Modbus/RTU (RS 485)
----------	---

Electrical data

Power supply	100 ... 240 VAC, 20 VA (option, KA66000A1663) 18 ... 30 VDC, 20 W (option, KA66000A1664)
--------------	---

Sensor supply	24 V, 10 W
---------------	------------

Data interface

Connection	Modbus/TCP (Ethernet), Modbus/RTU (RS 485), USB
------------	--

General data

Configuration

PC Software	S4C-Display software
-------------	----------------------

Display

Integrated	Size: 5" high-resolution graphic display Resolution: 800 x 480 pixels touch screen
------------	---

Material

Housing	PC + ABS
---------	----------

Miscellaneous

Electrical connection	Screw-Terminal connectors
-----------------------	---------------------------

Protection class	IP65
------------------	------

Approvals	CE
-----------	----

Weight	0.52 kg
--------	---------

Housing	Panel, wall mountable
---------	-----------------------

Dimensions	See dimensional drawing
------------	-------------------------

Cable entry diameter	4.5 ... mm
----------------------	------------

Cable	Supply: AWG 12 ... AWG 24, 0.2 ... 2.5 mm ² ; Signals: AWG 16 ... AWG 28, 0.14 ... 1.5 mm ²
-------	--

Weight	0.52 kg
--------	---------

Operating conditions

Ambient temperature	0 ... +50°C
---------------------	-------------

Ambient humidity	<90 %
------------------	-------

Storage temperature	-20 ... +70°C
---------------------	---------------

Transport temperature	-20 ... +60°C
-----------------------	---------------



Ordering

Please use the following tables to assist in placing your order with our sales staff.

S330 / S331 Display and Data Logger

Order No.	Description
-----------	-------------

KA66D5000333	S330 Display, Panel Version, 2 x SDI & 16 x Modbus/RTU input, Ethernet, RS 485, USB
KA66D5000331	S331 Display and Data Logger, Panel Version, 2 x SDI & 16 x Modbus/RTU input, Ethernet, RS 485, USB

Analog input

KA66000A1672	No analog input
KA66000A1662	2 analog inputs 0/4 ... 20 mA, 0 ... 10 V + 2 pulse inputs

Power supply (must choose one option)

KA66000A1663	Power supply input 100 ... 240 VAC, 20 VA, with 2 Alarm relays
KA66000A1664	Power supply input 18 ... 30 VDC, 20 W, with 2 Alarm relays

Wall casing

KA66000A1673	No wall casing, Panel mounting
KA66000A1665	Wall mountable casing with 4 cable glands
KA66000A1666	Wall mountable casing with 7 cable glands
KA66000A1667	Wall mountable casing with 3 cable glands + Ethernet
KA66000A1668	Wall mountable casing with 6 cable glands + Ethernet

Hat rail

KA66000A1674	No DIN rail holder
KA66000A1669	Hat rail holder (only in connection with wall mountable casing)

Accessories

Order No.	Description
-----------	-------------

Cables

KA66C2190055	M12 connector with RS-485 termination resistor, 120 Ω , for Modbus daisy chain termination
KA66A5543310	M12 RS-485 (Modbus) splitter
KA66A5530130	USB cable for S330 / S331 (1 cable included in S330 / S331)
KA66A5530104	Sensor cable 5 m with M12 connector, open wires, AWG 24 (0.2 mm ²)
KA66A5530105	Sensor cable 10 m with M12 connector, open wires, AWG 24 (0.2 mm ²)
KA66A5530106	Power cable with mains plug, 1.8 m
KA66A5530120	Ethernet cable 5 m, RJ45 plug at both ends

Converters and gateways (Please contact our customer service for further converter/gateway options)

KA66A5540011	RS-485 repeater
KA66A5540331	RS-485 / USB converter

Software

KA66M5992031	S4M, data acquisition and analyzes software
KA66000A1102	Add-on Energy Manager for S4M

Others

KA66D5540031	8-channel current input module, 0 ... 20 mA, Modbus/RTU
KA66A5540007	Power supply wall mountable
KA66A5540009	Power supply for hat rail
KA66A5543311	Line filter for EMC protection
KA66A5543313	Connection board for looping 4 ... 20 mA and pulse signals to PLC, mountable in wall casing KA66000A1666 or KA66000A1668



www.kompauto.com



sales@kompauto.com



S320



.STO Display



EASY TO USE
User-friendly design



POWER SUPPLY
Flexible power supply



ALARM
Optional alarm settings



USB INTERFACE
For configuration with S4C software



EASY INSTALLATION
Wall or panel mountable casing



SIGNAL INPUTS
Digital and analog input



Benefits

- ✓ Cost-efficient display unit for live readings on a big display
- ✓ Inputs for sensor connection:
 - 1 input for flow / dew point sensor
 - 1 input for analog sensors
- ✓ 2 relay outputs for alarm with optional alarm on display
- ✓ USB interface for configuration with S4C software
- ✓ Wall or panel mountable casing

Display Solutions for Sensors

The S320 Display provides a cost efficient display solution for industrial applications where information from a single difficult-to-access sensor is required. The display has an input for SUTO flow meters and dew point sensors.

It can display all relevant parameters (flow, dew point, pressure, temperature, power consumption, compressor status etc.) in a compressed air system.

Dimensions

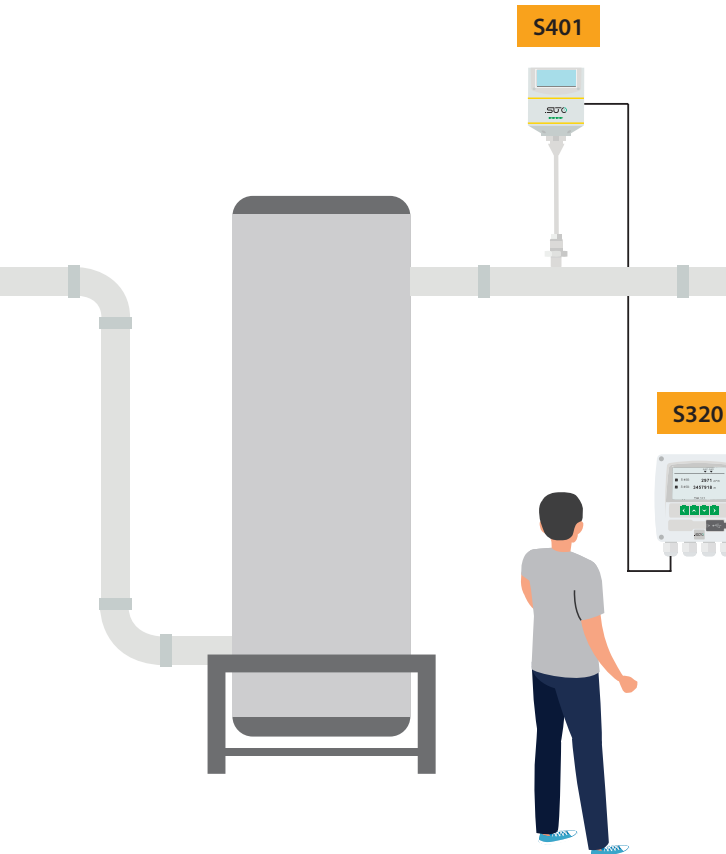
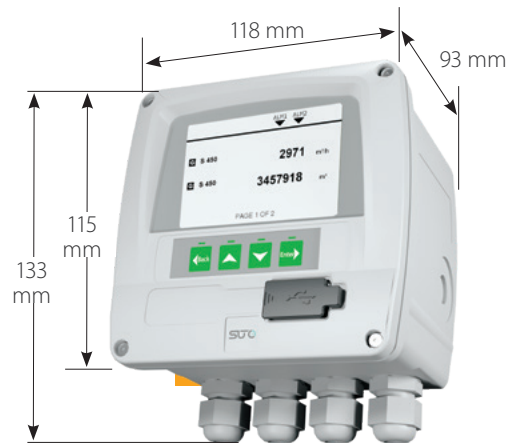

Inputs

- 1 input for SUTO flow/ dew point sensors
- 1 input for analog sensor (0 ... 20 mA, 0 ... 10V)

Outputs

- Communication Interfaces USB port
- Other Signals / Features
- 2 Alarm relay outputs



Technical Data

Signal / Interface & Supply

Input signals

Digital input	1 x SDI for dew point and flow sensors
Analog input	1 x 0 ... 20 mA or 1 x 4 ... 20 mA or
Pulse input	1 x 0 ... 10 V

Output signals

Alarm output	2 relays, 230 VAC, 3 A
--------------	------------------------

Electrical data

	100 ... 240 VAC, 15 VA (option KA66000A1640)
Power supply	18 ... 30 VDC, 15 VA (option KA66000A1641)
Sensor supply	24 V, 10 W

Data interface

Connection	USB to PC
Operation	Keyboard, 4 keys

General data

Configuration

PC Software	S4C-Display software
-------------	----------------------

Display

Integrated	Graphic display, 220 x 140 pixels with back light
------------	---

Material

Housing	ABS
---------	-----

Miscellaneous

Protection class	IP65
Approvals	CE
Weight	0.52 kg
Housing	Panel, wall mountable
Dimensions	See dimensional drawing
Cable entry diameter	4.5 ... 8 mm
Cable	Supply: AWG 12 ... AWG 24, 0.2 ... 2.5 mm ² ; Signals: AWG 16 ... AWG 28, 0.14 ... 1.5 mm ²
Weight	0.52 kg

Operating conditions

Ambient temperature	0 ... +50 °C
Ambient humidity	<90 %
Storage temperature	-20 ... +70 °C
Transport temperature	-30 ... +70 °C

Ordering

Please use the following table to assist in placing your order with our sales staff.

S320 Display

Order No. Description

KA66D5000320	S320 base unit, panel version, 1 input for SUTO sensor, 1 analog input
KA66000A1640	Power supply 100 ... 240 VAC, 15 VA, 2 relay outputs
KA66000A1641	Power supply 18 ... 30 VDC, 15 VA, 2 relay outputs
KA66000A1649	No wall casing (panel mount)
KA66000A1645	Wall mountable casing with 4 cable glands

Accessories

KA66A5530104	Sensor cable, 5 m with M 12 connector, open wires, AWG 24 (0.2 mm ²)
KA66A5530105	Sensor cable, 10 m with M 12 connector, open wires, AWG 24 (0.2 mm ²)
KA66A5530106	Power cable with mains plug, 1.8 m



www.kompauto.com



sales@kompauto.com



S551



Portable Display and Data Logger



AUTO DETECT
SDI or Modbus-based SUTO sensors



VERSATILE CONNECTION
Up to 24 sensors inputs



LTE / 4G MODEM
Access from world wide



TOUCH SCREEN
5" large color LCD



TIGHT PROTECTION
IP65



BACK-UP POWER
Battery as back-up power



Benefits

- ✓ Easy to use and cost-effective data logging solution at the point of use.
- ✓ S4A software for data analysis and remote connection via 4G / LTE Modem
- ✓ Connectable sensors for all required measurement tasks
- ✓ Up to 24 inputs through extension boxes and Modbus
- ✓ Third-party sensors can be easily connected

On site Logging

- Ultra portable and robust design to perform measurement tasks and audits on site
- High resolution 5" color touch screen interface, making the operation as simple as possible.
- Back up battery ensures continuous measurement and prevents data loss during power glitches and cuts.

Plug & Play

- With a few settings, the data logger is ready for operations with virtually unlimited memory size.
- No time consuming configuration and programming is required. Just connect the sensor and start the recording.

Optional Remote Connection

- Integrated USB port for 4G dongle connection outside the casing.
- Can be easily connected to the S4A Software and monitored remotely, no longer dependent on a Wi-Fi connection.



Wireless Connection

Compressor Efficiency Test

Knowing your Compressor Efficiency is the first step for your energy saving requirements

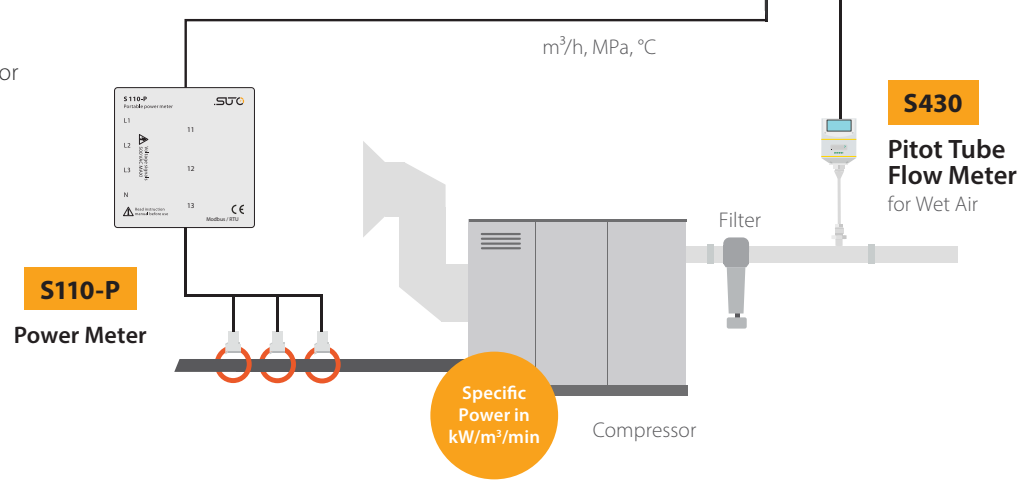



Applications

The S551 Portable Display and Data Logger is the perfect tool for compressed air service engineers as well as compressed air experts.

Due to its compact design and the integrated battery, on-site measurements are carried out most efficient user friendly. From simple dew point spot check up to identifying insufficient compressor systems, the S551 is the tool to make these measurements.



Remote Data Analysis

The S551 is capable of sending measurement data and status information to a remote server through the Internet. This allows users to monitor the system remotely. The illustration below shows the principle setup.

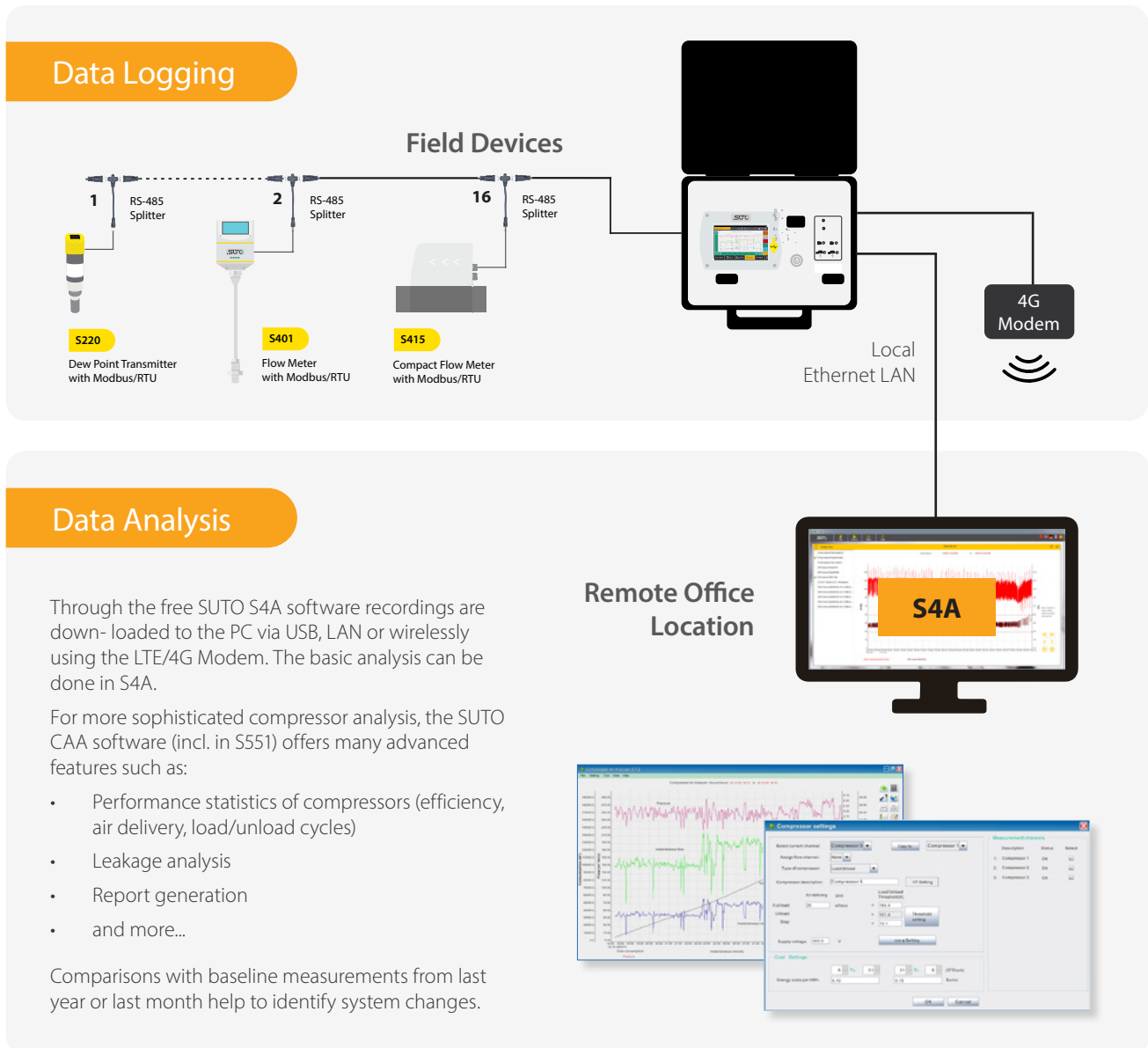

Versatile Connections and Sensor Inputs

- Connectable sensors for all required measurement tasks (air flow, air consumption, power consumption, pressure, temperature and many more)
- Up to 24 inputs through extension boxes and Modbus
- Third-party sensors can be easily connected



Industrial quick connectors allow a plug & play setup and ensure a reliable sensor connection.



Industrial Ethernet Port for LAN connections

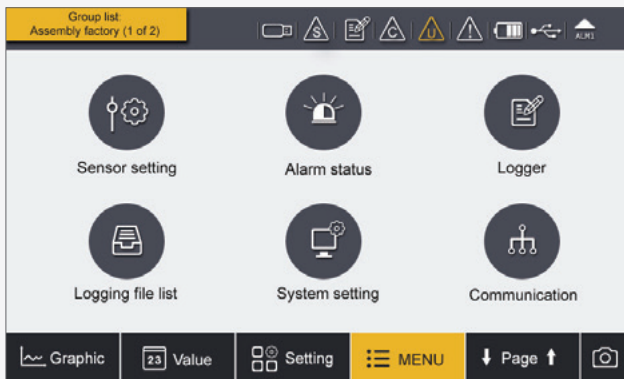

User Friendly Interface

The S551 comes with a high resolution 5" color touch screen interface making the operation as simple as possible.

SUTO intelligent sensors are detected automatically on power-up. With a few settings the data logger is ready for operations with virtually unlimited memory size.

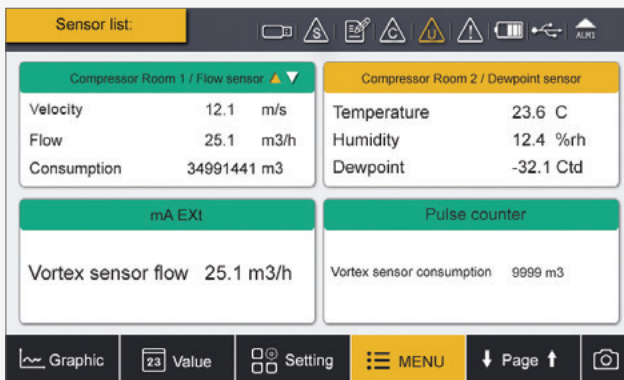

Sensor Data Overview

Up to 4 sensors can be viewed on one page and through page scrolling further sensors can be displayed.

This makes it easy to monitor different sensors at the same time.

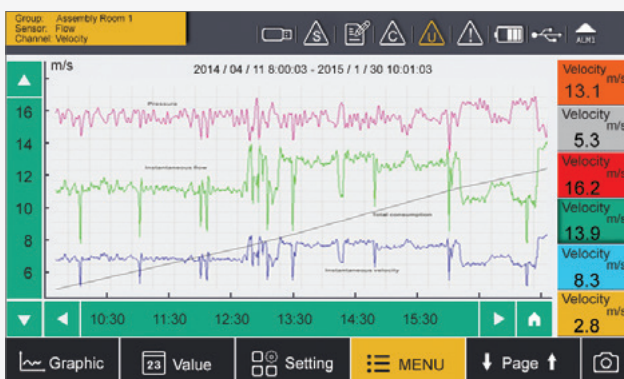

Graphic Charts for Quick Analysis

Select which channels you want to view or analyze and the built in graphic analyzer will help you identify problems immediately.

For detailed analysis we recommend using SUTO software S4A, CAA or S4M.



Technical Data

Signal / Interface & Supply

Data logger

Storage	4 GB, up to 100 million values
Sampling rate	The minimum time interval is 1 second

Digital input

Interface	2 x SDI connectors, 2 x Modbus/RTU connectors
Update rate	Value updated every 1 sec

No. of connectable Sensors

No. of connectable Sensors	2 x SDI sensors 16 x Modbus/RTU sensor
----------------------------	---

Analog input

Signal	Analog (0 ... 20 mA, 4 ... 20 mA, 0 ... 1 V, 0 ... 10 V), Pulse
Burden	max. 250 Ohm
Update rate	Value updated every 1 sec

Fieldbus output

Protocol	Modbus/RTU, Modbus/TCP
Update rate	Value updated every 1 sec

Other outputs

Communication Interface	4G/LTE (optional)
Purpose	View the online measurement values, read out the logging files remotely through S4A software and USB 4G dongle

Supply

Main power supply	100 ... 240 VAC, 50/60 Hz, 1.4 A
-------------------	----------------------------------

Data interface

Connection	USB micro, LAN (Ethernet)
Purpose	Read logger files & screenshots, show live data
Integrated web server	Remote monitoring (LAN)

General data

Configuration

PC Software	S4C-Display (via USB or LAN)
-------------	------------------------------

Display

Integrated touch screen	5" high resolution graphic display, 800 x 480 pixels with touch interface
-------------------------	---

Material

Housing	PC + ABS
---------	----------

Miscellaneous

Electrical connection	2 x M12 (5 pole) for SDI; 2 x Optional M12 (5 pole) for analog and pulse; 2 x M12 (5 pole) for Modbus; 1 x RJ45 Ethernet
-----------------------	--

Protection class	IP65 (only if the suitcase lid is closed and locked)
------------------	--

Weight	4 kg
--------	------

Operating conditions

Operating temperature	0 ... +50 °C
-----------------------	--------------

Storage humidity	< 90 %
------------------	--------

Storage temperature	-20 ... 50 °C
---------------------	---------------

Transport temperature	-20 ... 50 °C
-----------------------	---------------

Ordering

Please use the following tables to assist in placing your order with our sales staff.

	Data logger	
	KA66P5605100	S551-P4, Portable Display and Data Logger, 4 digital input channels, power cord, USB cable, S4A software, CAA software
	KA66P5605101	S551-P6, Portable Display and Data Logger, 4 digital input channels and 2 analog, power cord, USB cable, S4A software, CAA software
	KA66000A1670	USB 4G dongle for S551/S600, including S4A software
	Flow sensors	
	KA66S6010401	S401, 300 mm Shaft, insertion type thermal mass flow meter, max measuring range, DN15 ... DN300, Modbus/RTU, including 5 m cable with connector to S551
	KA66S6010430	S430, 220 mm Shaft, insertion type Pitot tube flow meter for wet air, DN25 ... DN250, Modbus/RTU, including 5 m cable with connector to S551
	Dew point sensor	
	KA66S6010215	S215 Dew Point Transmitter, -20 ... +50 °C Td, Measuring chamber with quick coupling, 5 m cable with connector to S551
	KA66S6010211	S211 Dew Point Transmitter, -60 ... +20 °C Td, Measuring chamber with quick coupling, 5 m cable with connector to S551
	KA66S6010220	S220 Dew Point Transmitter, -100 ... +20 °C Td, Measuring chamber with quick coupling, 5 m cable with connector to S551
	Pressure sensors	
	KA66S6941886	Pressure Transmitter, 0 ... 1.6 MPa(g), 4 ... 20 mA including a 5 m cable with connector to S551 (works only on S551-P6)
	KA66S6940356	Pressure Transmitter, 0 ... 4.0 MPa(g), 4 ... 20 mA including a 5 m cable with connector to S551 (works only on S551-P6)
	KA66S6941887	Pressure Transmitter, 0 ... 1.6 MPa(g), Modbus/RTU including a 5 m cable with connector to S551 (works on S551-P4 & P6)
	KA66S6941888	Pressure Transmitter, 0 ... 4.0 MPa(g), Modbus/RTU including a 5 m cable with connector to S551 (works on S551-P4 & P6)
	Amp sensor	
	KA66S5540156	Electrical Current Transmitter, 1000A, 100 mm diameter, including connector to S551
	KA66S5540157	Electrical Current Transmitter, 3000A, 150 mm diameter, including connector to S551
	Temperature sensor	
	KA66S6930005	Temperature Transmitter, -50 ... +200 °C, 4 ... 20 mA loop powered, 6 x 150 mm sensor tube, 5 m cable with connector
	KA66A5546003	Compression fitting, 6 mm, G 1/2" thread, 0.6 MPa
	KA66A5546004	Compression fitting, 6 mm, G 1/2" thread, 1.6 MPa
	Power meter (for 3 phase and single phase measurement)	
	KA66P5540134	Portable Power and Energy Meter S110-P, Modbus/RTU, including 4 test leads, 4 test clips, 5 m cable with connector to S551
	KA66S5540160	Electrical Current Transmitter for S110-P, 1000 A, 100 mm diameter, 1.8 m cable, connector to S110-P
	KA66S5540161	Electrical Current Transmitter for S110-P, 3000 A, 150 mm diameter, 1.8 m cable, connector to S110-P
	KA66S5540162	Electrical Current Transmitter for S110-P, 100 A, 160 mm diameter, 1.8 m cable, connector to S110-P
<p>Note: For 3 phases power supply 3 Rogowski coils are needed.</p>		

Ordering

Please use the following tables to assist in placing your order with our sales staff.

	Other sensors / extensions	
	KA66P5540080	8 channel analog input extension, connectable to S551, including 5 m cable with connector, 2-wire sensors support only Note: we offer other two models which supports 3-wire inputs and combination of 2-wire and 3-wire. Please contact the sales.
	Accessories	
	KA66A5530103	Extension cable, 5 m, male-female connectors
	KA66A5530110	Open wires cable, 5 m cable with connector
	KA66A5530111	Sensor cable, M12, 5 m with connector to S551
	KA66A5540035	Transport case S551 for sensors and cables, L560 x W450 x H160 mm (internal compartment can be arranged according to your individual sensor requirements)
	KA66A5540036	Transport case, customized for 1 x S110-P, 3 Rogowski coils, 4 x test leads, 4 x test clips, 1 x S430

* Please contact us for further accessories and details.



www.kompauto.com



sales@kompauto.com



Smart Compressed Air System Monitoring Software

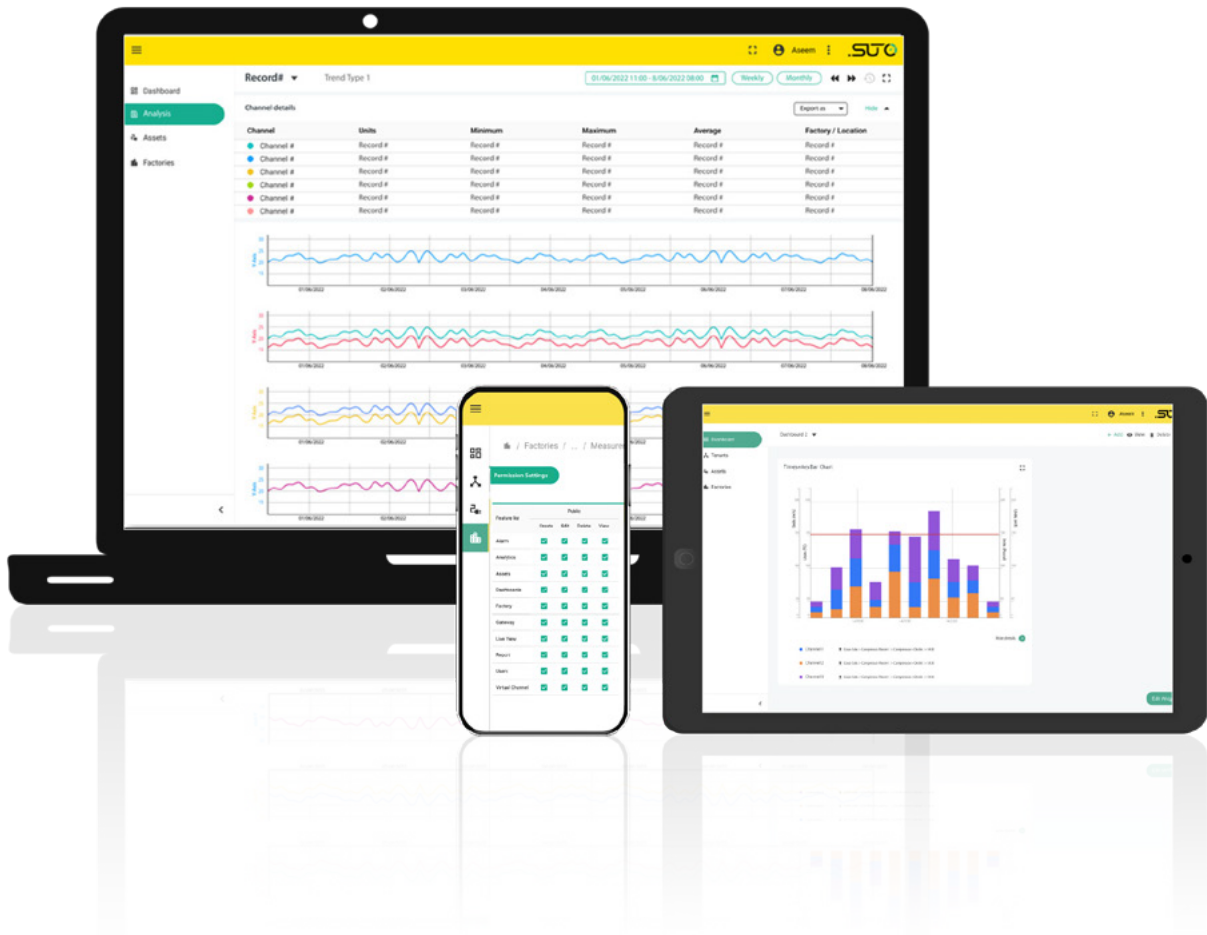

PROCESS VALUE VISUALIZATION



CUSTOMER MANAGEMENT



LIVE VIEW OF PROCESS DATA



POWERFUL REPORTING MODULE



EXTENSIVE DATA ANALYSIS



MONITORING & OPTIMIZATION



ALARMS & NOTIFICATIONS



PERSONALIZED INTERFACE



Benefits

- ✓ Ensuring system performance and reliability with remote monitoring and alarm management
- ✓ Energy saving and CO2 emission reduction by detecting system efficiency potentials
- ✓ Live monitoring of air production, usage and historical records for detailed system overview
- ✓ Minimization of initial CapEx by fast development and launch
- ✓ Easy to use plug & play solution for fast implementation of gateways and devices
- ✓ Auto-generate customized CAS reports for audits

Manage and ensure your whole compressed air system — reduce downtime and costs

S4M SaaS has been developed from the ground up with the focus on Compressed Air System Monitoring and Optimization.

The software allows end users to get their CAS under control, ensure their process safety and the reliability of their compressed air system. At the same time, the software offers compressed air service companies to have their client's system up and running, by simply checking the end client's CAS from anywhere at any time.

S4M SaaS not only gathers the measurement data from in-field devices, but with its built-in features, S4M SaaS actually is taking care of the complete system, from asset management, alarms, calibration & maintenance to consumption and energy reporting, all in one solution.

With S4M SaaS end users as well as service companies finally getting compressed air systems under control.

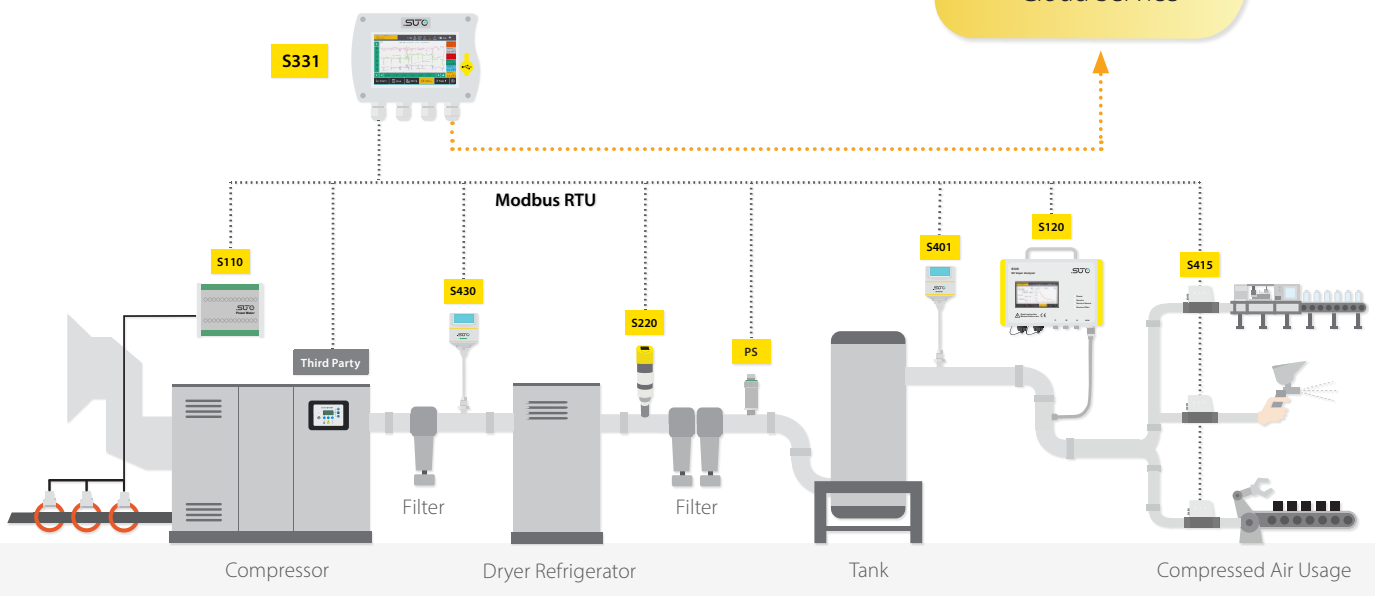
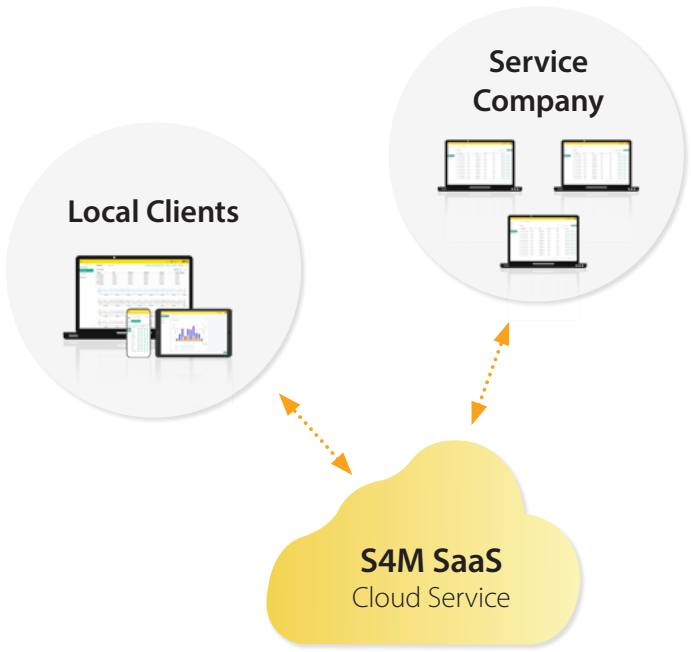



Customizable Dashboard

Dashboard for system overview and monitoring
 Real-Time data and graphical analysis from the dashboard
 Dashboard fully customizable to users needs with dashboard widgets
 Quick analyzes directly from

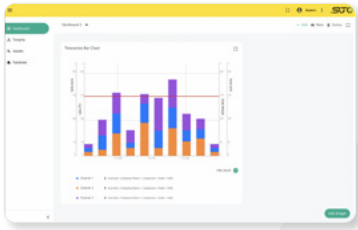

Powerful Data Analysis

Analyze all channels and parameters within a single module
 Compare historical data with actual data
 Benchmark your system and define KPIs
 Easily find weak spots and optimization potentials at a single



Live View of Process Data

Real-time measurement data of multiple factories and locations
 Live view of all measurement channels
 Drag & drop marker to place measurement data
 Upload system / factory plan to place your measurement device

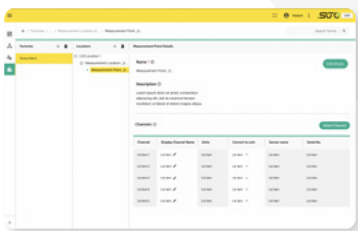
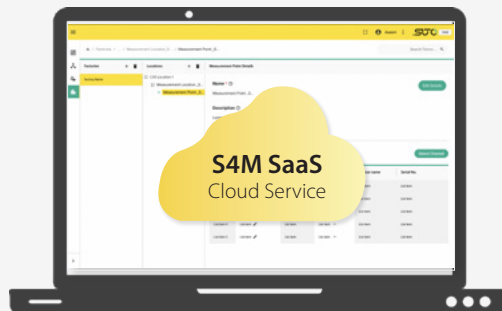
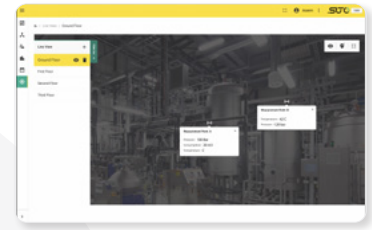

Location Management

Logical and easy to understand complex structures of field devices
 Define factories, measurement locations and measuring Points
 Assign factories to different customers
 Convert Measurement units

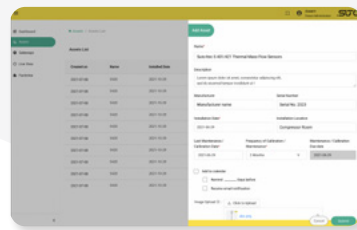

Asset Management

Track all components of the CAS in a single solution
 Create maintenance and calibration schedules and get notified in time
 Set up regular tasks on your CAS

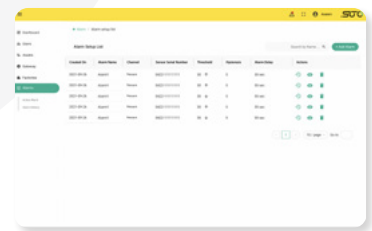

Alarm Management

System wide alarm management with full alarm history
 Active alarms list with mute functions during maintenance or repairs
 Assign alarms to any channel within the system
 Multiple on-screen alarm notifi-



Powerful User Access Right Management

- Easy to set up check-box based access-rights management
- Most flexibel user rights: Read-only accounts, default user accounts, multiple administrators
- Access rights management for each module
- Create private dashboards, alarms, analytics to be seen only by the specific user
- Set up multiple accounts and distribute their access rights

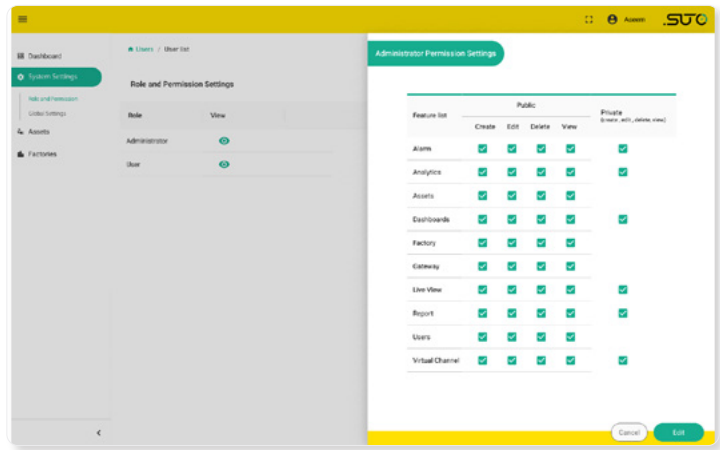

Create Powerful Reports

- Create powerful reports with a single Click
- Regular reporting with suggestions
- Energy cost and consumption reports
- Get reports sent automatically daily, monthly, weekly, quarterly or annually by Email
- Customize report colors and logos
- No more manual reporting needed so user can focus on more important things
- Set up management users to receive automatic financial reporting



Why Data Is So Important?

Compressed air is one of the most expensive energy forms and widely used in almost any application and process. Almost 50 % of the compressed air and gases that is generated is not used efficiently. Profound real-time system data will help to un-

- ✓ System Performance and Reliability
- ✓ Energy Efficiency and Cost Reduction
- ✓ Product Quality and Safety
- ✓ ISO Purity Requirements
- ✓ Carbon Footprint Reduction
- ✓ Less Maintenance and System Failures



Data Analysis

S4M SaaS
Cloud Service

Data Logging



S331 Data Logger and Display

Plug & Play gateway and central interface between field devices and S4M SaaS monitoring solution.

Connect up to 16 Modbus/RTU sensors, 2 analog sensors and 2 SDI sensors to a single data logger

Field Devices

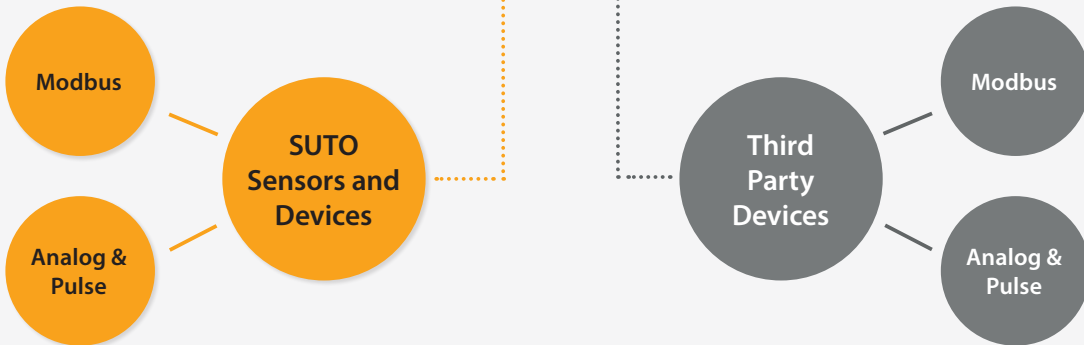

SUTO SDI and Modbus/RTU sensors as well as analog sensors can be connected to the S4M SaaS within minutes. To connect the Modbus/RTU sensors properly on an RS 485 bus system, it's recommended to daisy-chain the sensors to one of the inputs. For this purpose, SUTO offers a RS 485 splitter to simplify the connection. Through this method, users can add up to 16

By relying on the industry standard protocol Modbus/RTU, third-party sensors and device can be easily integrated into the S4M SaaS through the S331 Data Logger Gateway. Field devices can be easily set up using the configuration software, allowing to add a third-party sensor within seconds.

Of course, all connected sensor data can





User and Access

End User License

The End User License is made for the Compressed Air System Operators and Facility Management.

This License grants access to the own compressed air system throughout the whole factory and among multiple locations. The system can be accessed by multiple users within the same organization.

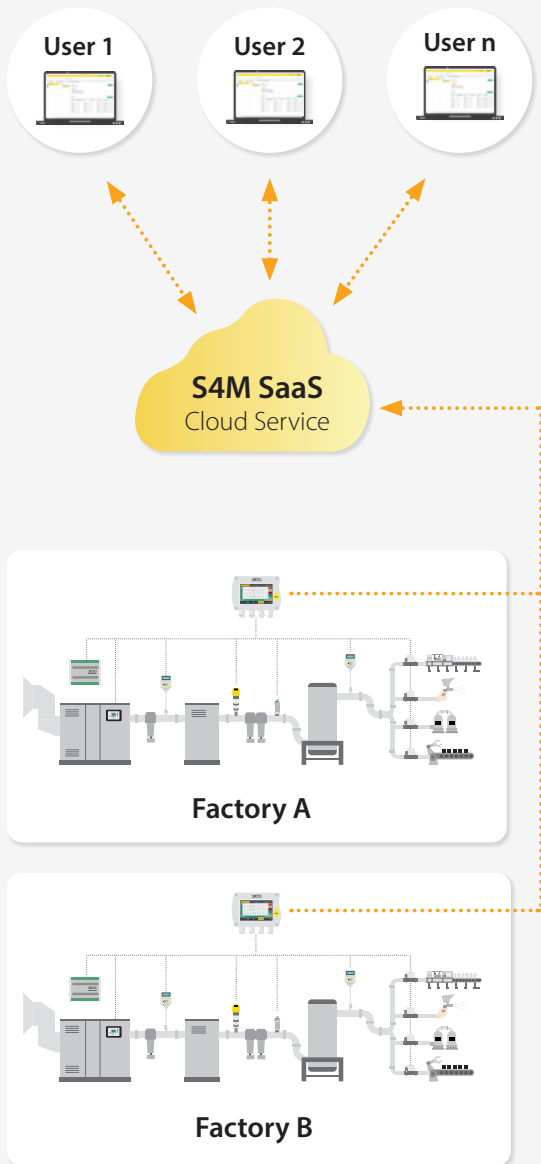

Service Provider License

The Service Provider License is made for Compressed Air Service Companies, which are offering their service for clients. Service Companies are enabled to monitor their clients compressed air systems, all over the world.

Each client is separated and the Service provider is enabled to grant the end clients access to their own system.

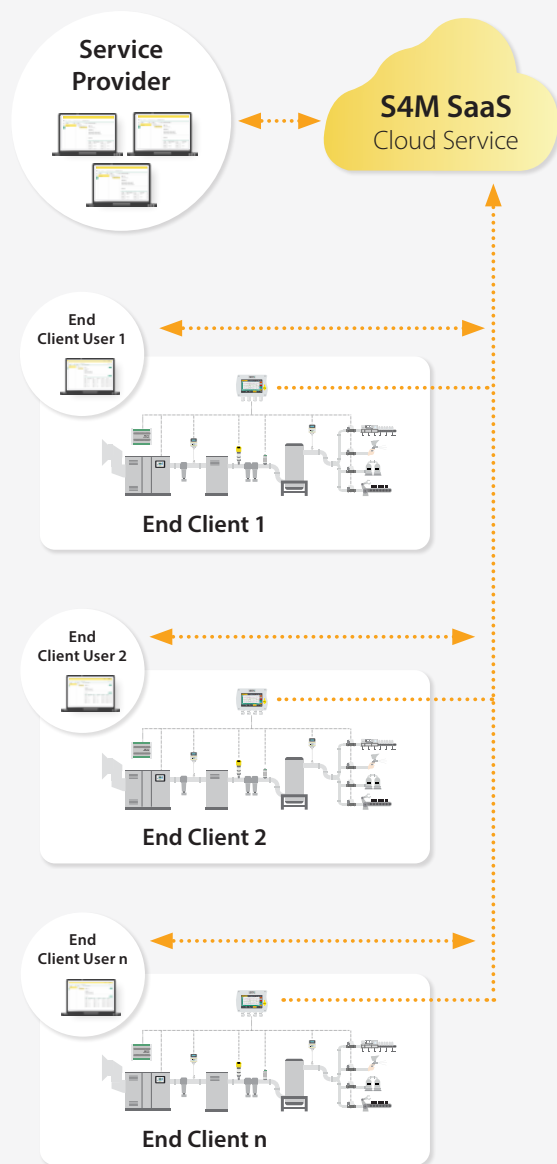



License Packs

	Trial	Starter	Essentials	Team	Enterprise
License Type	End User	End User	End User	Service Provider	Service Provider
User	1	1	5	10	100
Number of Channels	5	20	50	100	500
Add Additional Channels	X	✓	✓	✓	✓
Add Additional Users	X	✓	✓	✓	✓
License	Free (For 90 Days)	Annual Subscription	Annual Subscription	Annual Subscription	Annual Subscription

Contact Us

Please contact our sales to assist you finding the license type which suits your requirements.

SWEDEN

+46 (0)10 130 10 00

sales@kompauto.com

NORWAY

+47 55 55 86 99

sales@kompauto.com

Explanations

User

A user is a login who can access the system and full functionalities. User access rights can be controlled by the administrator and set individually.

One user is always the administrator with all access rights.

Channels

Each Measurement value is represented as a channel.

Example: 1 Flow Meter (Flow and Consumption = 2 channels) + 1 Dew Point Meter (Dew point, Temperature and Humidity = 3 channels) results in a total of 5 channels.

Created virtual channels are represented as a channel and part of the total channels available



www.kompauto.com



sales@kompauto.com



S4A



Data Analysis Software



GRAPHIC ANALYSIS
Powerful graphic analysis



ONLINE READING
Real time data reading with USB or Ethernet connection



FREE TO USE
No payment or subscription needed



ANALYSIS ON EXPORTED FILES
Export data to the .XLSX and .CSV file



READOUT OF SCREENSHOTS
Read screenshots from SUTO S331



REMOTE CONNECTION
Read out field devices via Internet connections

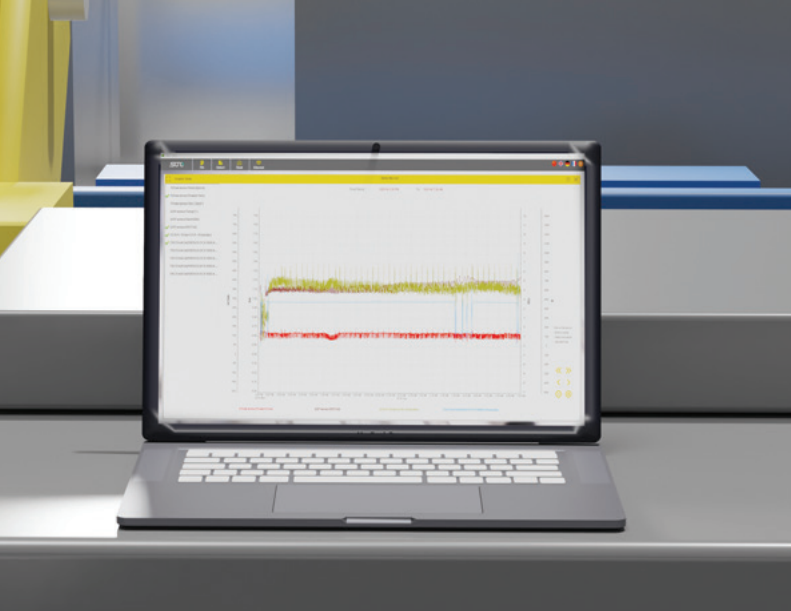

Benefits

- ✓ Free software with quick analysis through powerful graphs and exported tables
- ✓ On-site real time analysis through online data reading
- ✓ Remote access of SUTO displays and Loggers that are equipped with LTE/4G modem
- ✓ Easy installation with installation wizard
- ✓ Multiple languages available

Data Analysis with S4A

S4A is a stand alone free software used to analyze measurement data recorded by SUTO data loggers. Local stored logger files from any SUTO device with logging function can be opened, analyzed and exported.

- Real-time online readings of a SUTO device via a USB , Ethernet or wireless LTE/4G connection.
- Powerful graphic tools allowing basic and in-depth analyzes of the data and prepare reports.
- Easy to set up interface for hassle-free use. No complicated setup menus or configurations. Simply connect SUTO data loggers and read logging files with a single click.
- Integrated export function offers data exchange in .xlsx and .csv format.
- Software recordings are downloaded to the PC via USB, LAN or wirelessly using the LTE/4G Modem.
- The wireless connection offers full functionality as if the devices would be connected via USB. This makes it most flexible and versatile.

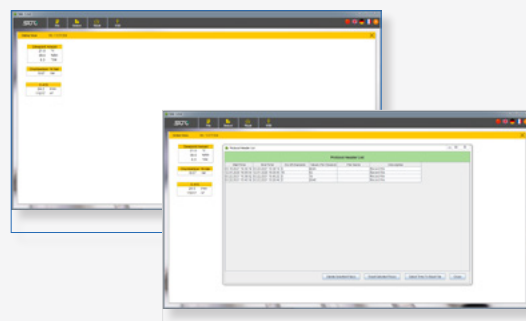

Remote Office Location

S4A

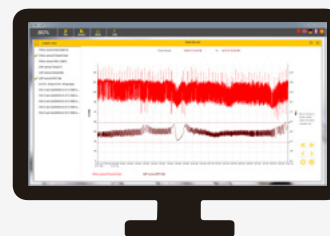

Local Ethernet LAN

Data Logging

S331 Data Logger

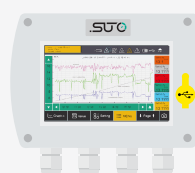

Field Devices

Modbus/RTU Sensors

Analog Sensors

Download

The S4A Software is offered for free and the latest version can be downloaded from the SUTO homepage, no registration or subscription needed.

www.kompauto.com



S4C



Smartphone Apps

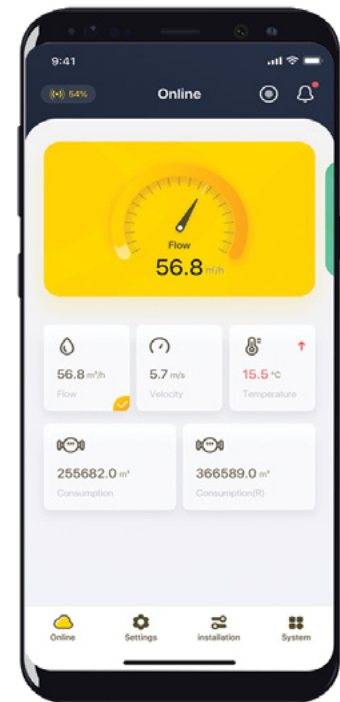
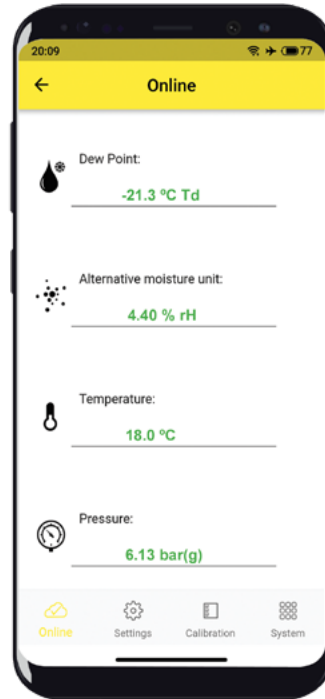
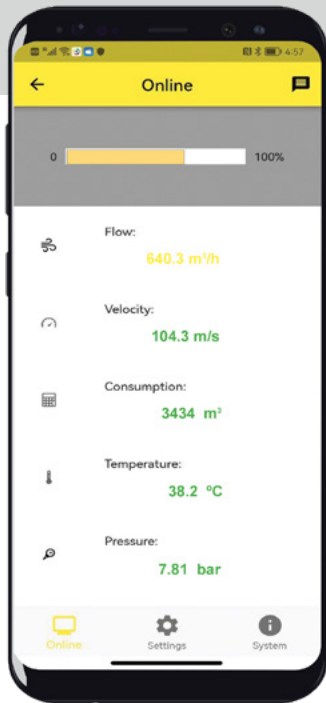

FREE SMARTPHONE APPS
For remote Configuration



ONLINE READING
Live measurement data



EASY TO USE
User-friendly design



WIRELESS CONNECTION
Connection to devices in hard-to-reach places

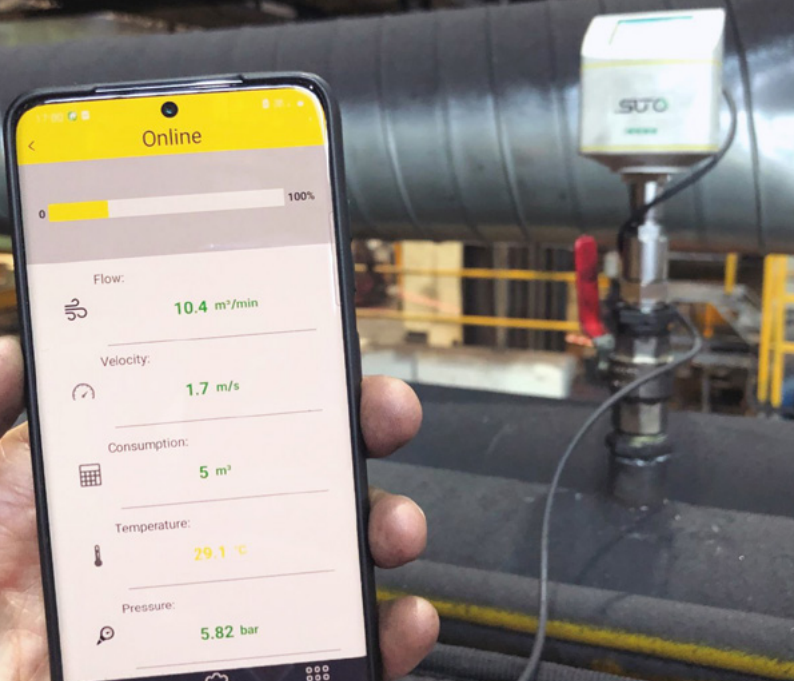

Benefits

- ✔ Wireless connection to SUTO iTEC field devices
- ✔ On-site configuration without the need of PC; everything runs from your smartphone
- ✔ Third-party access protection by QR code protected settings
- ✔ Real-time data readings and sensor settings
- ✔ User friendly design with intuitive workflows
- ✔ No registration or subscription needed
- ✔ Online Configuration and guided setup as well as customer calibration features

S4C-FS App for SUTO Flow and Consumption Meters

- Connect wirelessly to SUTO flow and consumption sensors
- Download for Android® and iOS® smartphones
- Live data in the palm of your hands
- On-site configuration and settings
- Fast commissioning of field devices
- User calibrations
- Data logger settings and operations

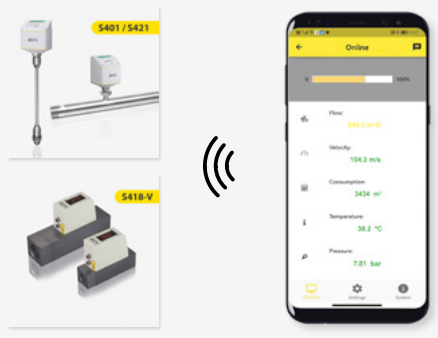

S4C-DP App for SUTO Dew Point Meters

- Connect wirelessly* to SUTO dew point sensors
 - Download for Android® and iOS® smartphones
 - Live sensor readings on your smartphone
 - On-site configuration and settings
 - Fast commissioning of field devices
 - User calibrations and adjustments
- *needs the optional Wireless-DP-Adapter

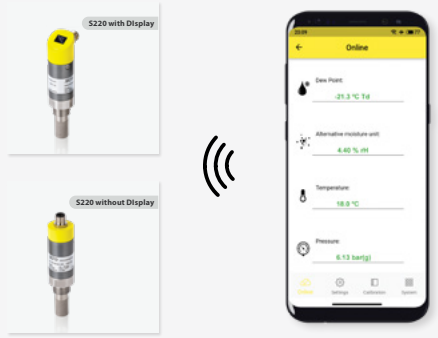

S4C-US App for SUTO Ultrasonic Meters for Liquids

- Connect wirelessly to SUTO ultrasonic flow meters
- Download for Android® and iOS® smartphones
- Guided setup and installation
- Adjust installation parameters and get signal quality feedback
- Actual Flow and Total consumption as well as historical data
- On-site configuration and settings
- User calibrations



www.kompauto.com



sales@kompauto.com



S120



Oil Vapor Monitor



Opt. 1

Without Display

Opt. 2

With Display



ACCURATE RESULTS
Latest PID sensor technology



TOUCH SCREEN
For easy operation



EASY INSTALLATION
Plug and Play Solution



COMPACT DESIGN
Fits into your application



DATA LOGGER
Integrated as option



DEW POINT SENSOR
Option:
-100 ... +20 °C Td



Benefits

- ✔ Plug & Play setup with quick connections. Can be used in portable and stationary applications.
- ✔ Oil vapor measurement in a range of 0.001 to 5.000 mg/m³
- ✔ Various output signals to connect the unit to building management systems
- ✔ PID sensor technology for fast response time and Online monitoring
- ✔ Optional with integrated 5" touch screen display with data logger function
- ✔ Optional with integrated dew point measurement
- ✔ LED indications for status and alarms



Simple Installation – Outstanding Performance

The S120 is designed to offer users an efficient way of measuring residual oil contents in a compressed air system.

The integrated automatic calibration compensates temperature and humidity drifts in the supplied air, resulting in most accurate, reliable and long term stable measurement results.

The simple plug & play installation, as well as its outstanding performance, makes the S120 the ideal choice when oil vapor needs to be measured and monitored.

Optional Integrated Dew Point Sensor

To ensure compressed air quality and purity, dew point measurement is an essential key parameter. Therefore, we offer an optional integrated Dew Point Sensor, -100 ... +20 °C Td, to measure both parameters in one compact device with an excellent price performance ratio.

Applications

Oil free compressed air is not an easy task to be achieved. Monitoring is a must in many industries and applications to avoid contamination in products and risks for health of humans.

- Medical air
- Pharmaceuticals
- Breathable air for rescue workers and divers
- Food and beverage
- Semiconductor fabs
- Conveyance of hygroscopic food
- High tech processes

Output Signals

- 4 ... 20 mA analog output
- Modbus/RTU and Modbus/TCP (TCP only with Display version)
- Alarm Relay

S120

Portable and stationary Solution



Environmental Contaminants

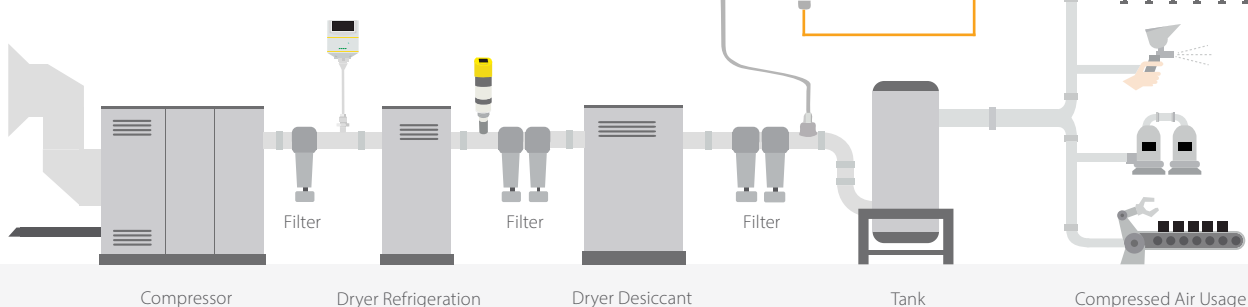

Compressor

Dryer Refrigeration

Dryer Desiccant

Tank

Compressed Air Usage



Technical Data

Measurement

Oil Vapor

Measuring range	0.001 ... 5.000 mg/m ³ (Based on 1000 hPa(a), 20 °C, 0% relative humidity)
Accuracy	5% of reading ± 0.003 mg/m ³
Resolution	0.001 mg/m ³
Selectable units	mg/m ³ / ppm
Sensor principle	Photo ionization detector

Pressure

Measuring range	0 ... 16 bar(g)
Accuracy	0.5 % FS
Resolution	0.01 bar(g) / 0.001 MPa / 0.1 psi
Selectable units	bar(g) (default), MPa and psi (on request)
Sensor principle	Piezo resistive pressure sensor

Dew Point (optional)

Measuring range	-100 ... +20 °C Td
Accuracy	±1 °C Td (0 ... 20 °C Td) ±2 °C Td (-70 ... 0 °C Td) ±3 °C Td (-100 ... -60 °C Td)
Resolution	0.1 °C Td
Selectable units	°C Td / °F Td
Sensor principle	QCM + Polymer

Temperature

Measuring range	0 ... 50 °C
Accuracy	0.5 °C
Resolution	0.1 °C
Selectable units	°C / °F
Sensor principle	NTC

Signal / Interface & Supply

Outputs / Interface

Analogue output	4 ... 20 mA, isolated
Alarm output	Relay, NO, 40 VDC, 0.2A
Digital interface	Modbus/RTU (RS485) Modbus/TCP (Ethernet) & USB (only available for display version)
Display (optional)	5" color touch screen with a data logger of 100 million measurement values

Supply

Power supply	24 VDC ± 5 %, 10 W
--------------	--------------------

- Power
 - Alarm
 - Service Sensor
 - Service Filter
- LEDs indicate if pre-set alarms are reached, or if filters and sensors need to be serviced. The service indications start blinking 4 weeks before expiring and turn on permanently when a service is immediately required.

General Data

Measuring medium	Compressed air, N ₂ , CO ₂ (for other gases please contact us)
Sample flow rate	< 2 l/min, measuring gas is released to ambient
Sample rate	1/sec
Gas / Operating temperature	-20 ... +50 °C
Transport temperature	-30 ... +70 °C
Operating pressure	3 ... 15 bar(g) 0.5 ... 2 bar(g) (optional) 0.60 ... 1.07 bar(a) (ambient version only)
Gas humidity	< 40 % rel. humidity, no condensation
Gas connection	6 mm quick connect
UV lamp lifetime	6,000 working hours or 1 year, whichever comes first
Electrical connection	M12, USB, RJ45
Settings	Various sensor settings can be performed through SUTO display units or through the related service software
Housing material	PC, Al alloy
Protection class	IP65
Dimensions	271 x 231 x 91 mm
Weight	2.4 kg
Approval	CE





Ordering

Please use the following table to assist in placing your order with our sales staff.

S120 Oil Vapor Monitor

Order No.	Description
KA66S6041201	S120, Oil Vapor Monitor, 0.001 ... 5.000 mg/m ³ , 4 ... 20 mA output, RS-485, alarm output, supply 24 VDC, incl. power supply
KA66S6041202	S120-P, Portable Oil Vapor Monitor, 0.001 ... 5.000 mg/m ³ , 4 ... 20 mA output, RS-485, alarm output, connectable to S551, transport case, incl. power supply
KA66S6041203	S120, Oil Vapor Monitor, 5" touch screen, 0.001 ... 5.000 mg/m ³ , 4 ... 20 mA output, RS-485, alarm output, supply 24 VDC, incl. power supply
KA66P6041205	S120-P, Portable Oil Vapor Monitor, 5" touch screen, 0.001 ... 5.000 mg/m ³ , 4 ... 20 mA output, RS-485, alarm output, 24 VDC supply, incl. transport case, power supply
KA66P6041215	S120-Ambient Portable Oil Vapor Monitor for ambient air, 5" touch screen with data logger, 0.001 ... 5.000 mg/m ³ , 4 ... 20 mA, RS-485 (Modbus RTU), Ethernet (Modbus TCP), alarm output, integrated pump, supply voltage 24V DC, incl. power supply and transport case.
KA66000A1250	Option: Integrated dew point sensor, -100 ... +20 °C Td (only for KA66S6041203 and KA66P6041205)
KA66A5541203	Oil vapor zero filter, 1.5 MPa max, with quick connectors at both ends
KA66A5541207	Replacement kit for zero filter oil vapor analyzer
KA66A5540120	Option, Transport case S120/130
KA66R2000120	S120 General service and re-calibration (for all models without Dew Point Sensor option KA66000A1250): <ul style="list-style-type: none"> - General inspection of the unit - Replacement of tubes and fittings - Cleaning of lamp and sensor - Assembly and test of unit - Calibration of oil sensor - Calibration Certificate
KA66R2000121	S120 General service and re-calibration with dew point sensor option (for KA66S6041203 and KA66P6041205 with Dew Point Sensor Option KA66000A1250): <ul style="list-style-type: none"> - General inspection of the unit - Replacement of tubes and fittings - Cleaning of lamp and sensor - Assembly and test of unit - Calibration of oil sensor - Calibration of dew point sensor - Calibration Certificate



www.kompauto.com



sales@kompauto.com



S130 / S132



Laser Particle Counter



ECO ($0.3 < d \leq 5.0 \mu\text{m}$)

S130



S132

PRO ($0.1 < d \leq 5.0 \mu\text{m}$)



PARTICLE MEASUREMENT
According to ISO-8573 Standard



EASY INSTALLATION
Plug and Play Solution



PRO VERSION S132
Smallest channel $0.1 < d \leq 0.5 \mu\text{m}$



ECO VERSION S130
Smallest channel $0.3 < d \leq 0.5 \mu\text{m}$



Benefits

- ✓ Accurate compressed air quality measurements and monitoring with particle size ranges:
0.1 < d ≤ 0.5 μm / 0.5 < d ≤ 1.0 μm / 1.0 < d ≤ 5.0 μm / d > 5.0 μm
- ✓ Classify the compressed air systems according to ISO 8537-1 while being in compliance with the ISO 8573-4
- ✓ Easy connection to compressed air system through a 6 mm hose with quick connectors
- ✓ Integrated pressure diffuser suitable for inlet pressure ranges of 3 ... 15 bar(g)
- ✓ Optional 5" touch screen integrated for live data readings and data logging functions
- ✓ Designed to be used in stationary monitoring solutions, as well as in portable audit measurements

Reliable particulates counts in compressed air systems

The SUTO S130 / S132 Laser Particle Counters are optimized for 24/7 compressed air quality monitoring. Unlike its competition, the SUTO laser particle counters are coming with integrated pressure diffusers to reduce the line pressure inside the instrument. Users are enabled to use the laser particle counters directly at the compressed air system, without installing pressure reducers and therefore being in compliance with the ISO 8573-4 standard.

The measurement values are displayed in counts per volume (cn/m3), but can also display alternative volume units like cubic-feet or liter.

The integrated display offers live readings for all channels, signal output settings as well as an integrated data logger, to store the measurement data on the device.

Applications

Particle free compressed air is not an easy task to be achieved. Monitoring is a must in many industries and applications to avoid contamination in products and health risks for humans.

- Medical air
- Pharmaceuticals
- Breathable air for rescue workers and divers
- Food and beverage
- Semiconductor fabs
- Conveyance of hygroscopic food
- High tech processes

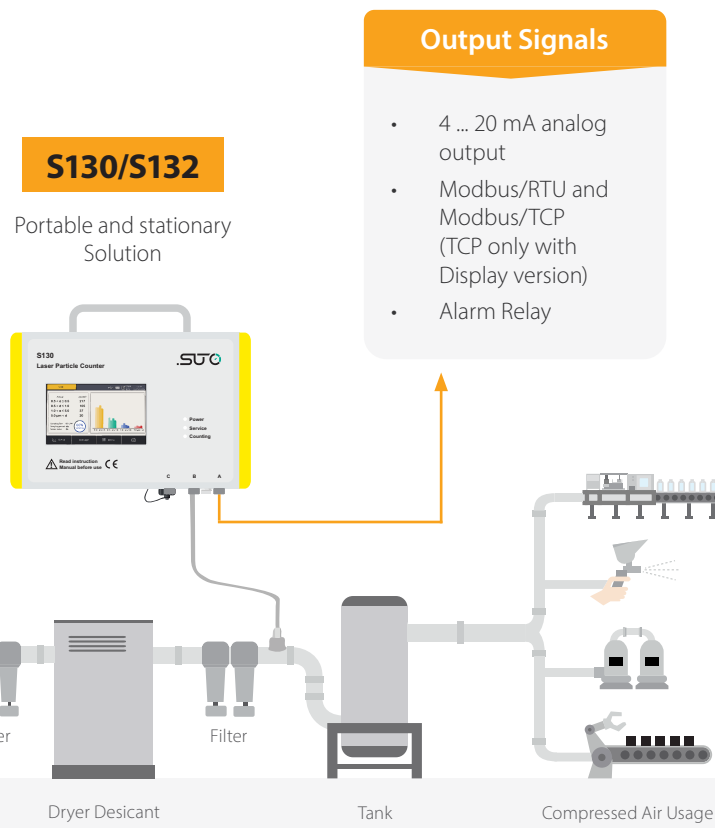



Particulates in Paint Shops

In a modern paint shop, the painting quality highly depends on the quality of the compressed air. Modern paint systems inject the paint into the paint gun, where compressed air is driving the paint through the nozzle. When existing the nozzle, the paint atomizes into a fine and uniformed mist. These tiny paint particles repel each other as they are leaving the nozzle and stick to the object being painted.

Excess impurities in the compressed air will cause the paint particles to "clump", resulting in uneven coverage and an inconsistent finish.

The only way to secure this high-quality painting process is by monitoring the particle concentration of the compressed air supply.



Air Quality Monitoring according to the ISO 8573-1

The ISO 8573-1 defines the compressed air purity classes for particulates in a compressed air system by providing the limit values for each channel.

The S132 Laser Particle Counter measures the channels as defined by the ISO 8573-1:

- $0.1 < d \leq 0.5 \mu\text{m}$
- $0.5 < d \leq 1.0 \mu\text{m}$
- $1.0 < d \leq 5.0 \mu\text{m}$

For these 3 channels, the limit values are defined and divided into classes.

But furthermore, as stated in the ISO 8573, the fourth channel must be measured as well:

- $d > 5.0 \mu\text{m}$

This channel value must be 0 for the classes 0 ... 5, as otherwise the classification falls into class 6 or worse, where a mass concentration is defined as limit values.

Certain industries like the pharmaceutical and food industry requires high-quality compressed air. By meeting the ISO 8573-1 standard requirements you can:

- ✔ **Ensure Process and Product Safety:**
Contaminants mixing with applications effect product results and can create safety concerns.
- ✔ **Prevent production downtime:**
Processes and machines are stopped to find and eliminate the contamination issues.

S130



S132





Technical Data

Measurement

Particle

Measuring range	S130: $0.3 < d \leq 5.0 \mu\text{m}$ S132: $0.1 < d \leq 5.0 \mu\text{m}$
Measuring channels	S130: CH1: $0.3 < d \leq 0.5 \mu\text{m}$ CH2: $0.5 < d \leq 1.0 \mu\text{m}$ CH3: $1.0 < d \leq 5.0 \mu\text{m}$ CH4: $5.0 \mu\text{m} < d$ (configurable) S132: CH1: $0.1 < d \leq 0.5 \mu\text{m}$ CH2: $0.5 < d \leq 1.0 \mu\text{m}$ CH3: $1.0 < d \leq 5.0 \mu\text{m}$ CH4: $5.0 \mu\text{m} < d$ (configurable)

Counting efficiency according ISO 21501-4	S130: 30 ... 70 % of $d > 0.3 \mu\text{m}$, 90 ... 110 % of $d \geq 0.45 \mu\text{m}$ S132: 30 ... 70 % of $d > 0.1 \mu\text{m}$, 90 ... 110 % of $d \geq 0.3 \mu\text{m}$
---	---

Principle of measurement Laser detection

Sensor LED-laser

Consumption

Selectable units $\text{cn}/\text{m}^3, \text{cn}/\text{ft}^3$

Signal / Interface & Supply

Analog output

Signal 4 ... 20 mA (2-wire)

Alarm Switch output, normally open,
max. 40 VDC, 200 mA

Fieldbus

Protocol Modbus/RTU, , Modbus/TCP (with Display version)

Supply

Voltage supply 24 VDC / 10 W (without Display)
24 VDC / 20 W (with Display)

Current consumption 420 mA (without Display)
840 mA (with Display)

Data interface

USB USB Micro with OTG support

General data

Configuration

Others Device comes pre-configured
Configuration can be done via on-screen touch

Display

Integrated 5" color touch screen

Data Logger

Storage 100 million measurement values (optional)

Miscellaneous

Electrical connection 3X M12

Protection class IP65

Process connection 6 mm quick connect (pressurized version), barb connection (ambient version)

Material PC, Al alloy

Weight S130: 1.9 kg
S132: 3.2 kg

Dimensions S130: 271 x 205 x 91 mm
S132: 300 x 240 x 120 mm

Operating conditions

Medium Compressed air and gases free of corrosive, aggressive, caustic and flammable constituents

Flow rate 2.83 l/min

Sample rate One sample per minute

Medium quality ISO 8573-4

Medium temperature 0 ... +40 °C

Medium humidity < 90 %, no condensation

Operating pressure 0.3 ... 1.5 MPa

Ambient temperature +10 ... +40 °C

Ambient humidity 0 ... 90 % rH

Storage temperature -10 ... +50 °C

Storage humidity < 90 % with no condensation

Transport temperature -30 ... +70 °C Without display
-10 ... +60 °C with display



Ordering

Please use the following tables to assist in placing your order with our sales staff.

Particle Counter for Compressed Air: P = 0.3 ... 1.5 Mpa

Order No.	Description
KA66S6041303	S130, Particle Counter for Compressed Air, size range d: 0.3 < d ≤ 5.0 μm, 2.83 l/min
KA66S6041305	S130, Particle Counter for Compressed Air, size range d: 0.3 < d ≤ 5.0 μm, 2.83 l/min, display, logger
KA66S6041308	S132, Particle Counter for Compressed Air, size range d: 0.1 < d ≤ 5.0 μm, 2.83 l/min
KA66S6041309	S132, Particle Counter for Compressed Air, size range d: 0.1 < d ≤ 5.0 μm, 2.83 l/min, display, logger

Accessories

Order No.	Description
KA66A5540120	Transport case S120 / S130
KA66A5540116	Transport case S132
KA66A5541204	Zero count filter
KA66R2000130	Calibration particle counter S130
KA66R2000131	Calibration particle counter S132



www.kompauto.com



sales@kompauto.com



S600



Portable Compressed Air Purity Analyzer



**ISO 8573-1
ALL IN ONE**
Particle concentration,
Dew Point, Oil vapor

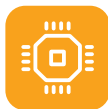

**GUIDED
MEASUREMENT**
Software guided air
quality audits



**PORTABLE
MULTI-TOOL**
Can be carried
with one hand



**HIGH
PRECISION**
Accurate
measurements



**COMPACT
DESIGN**
Makes it
unique



**PDF
REPORTING**
Create ISO 8573-1
reports on the device



Benefits

- ✓ All-in-one device measures Particle concentration, dew point and oil vapor
- ✓ Measures additionally the temperature and pressure
- ✓ Software guided measurement makes it easy to generate reliable results
- ✓ Report generator creates PDFs for ISO 8573-1 audits
- ✓ Ultra portable and compact design

Plug & Play Measurement — Save Precious Time

ISO 8573 compliant purity quantifications of compressed air systems are bound to time-consuming installations and long-lasting test runs ... It's time for a revolution: The S600 is unlike its competition.

It combines the latest sensor technology, software-guided measurements and a time-saving setup into a handy, touchscreen controlled multi-tool. With our S600 you will finish measurement runs in much less time than with your traditional method, after that you don't ever want to leave your new comfort zone again. Trust us.

Remote connection

By connecting a LTE/4G modem to the designated USB port, S600 can be monitored remotely through S4A software

Monitoring of All Relevant Contaminants

Particle Concentration Measurement

$0.1 < d \leq 0.5 \mu\text{m} / 0.5 < d \leq 1.0 \mu\text{m} / 1.0 < d \leq 5.0 \mu\text{m} / 5.0 \mu\text{m} < d$

Dew Point Measurement

-100 ... +20 °C Td

Oil Vapor Measurement

0.001 ... 5.000 mg/m³

ISO 8573-1 Classification

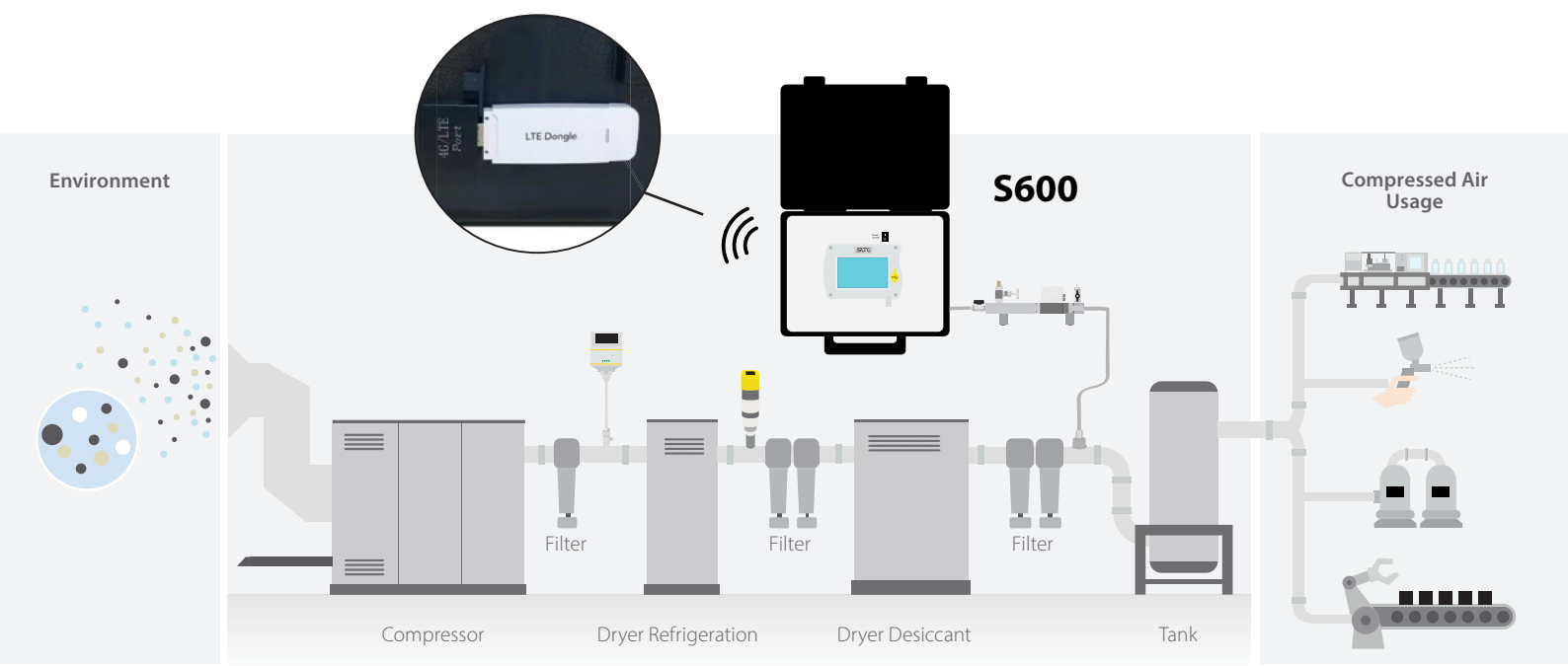



5 in 1 Measuring Device

The S600 is the portable multi-tool for ISO 8573-1 compressed air purity measurements. It measures, records and validates quality parameters like particle concentration, dew point, oil vapor contents, temperature and the pressure of compressed air systems.



Particle Concentration Measurement

- Measurement methods according to ISO 8573-4 standards (together with isokinetic sampling device)
- Latest laser detection technology
- Smallest particle size 30 ... 70 %, next bigger sizes 90 ... 110 % per ISO 21501-4



Dew Point Measurement

- Large ranges due to the unique multiple sensor technology
- Long-term stable and well-proven measurement methods
- High precision with an accuracy of ± 2 °C Td



Oil Vapor Measurement

- Latest photoionisation detector (PID) with self-calibration
- Measuring range according to ISO 8573-1 Class 1 to Class 5
- High precision with 5 % of reading ± 0.003 mg/m³ accuracy



Pressure Measurement

- State of the art sensor technology
- Additional quality data about the compressed air system



Integrated Data Logger

- Integrated data logger records all channels in parallel for later analysis
- 5" touchscreen allows you to interact with the device on site. There is no need for a PC to manage the device.

ISO 8573-4 Isokinetic Sampling Device

For particle measurements according to ISO 8573 an isokinetic sampling tube has been designed. This optional equipment enables you to monitor and adjust the air flow of the particle measurement to ensure the correct isokinetic sampling.

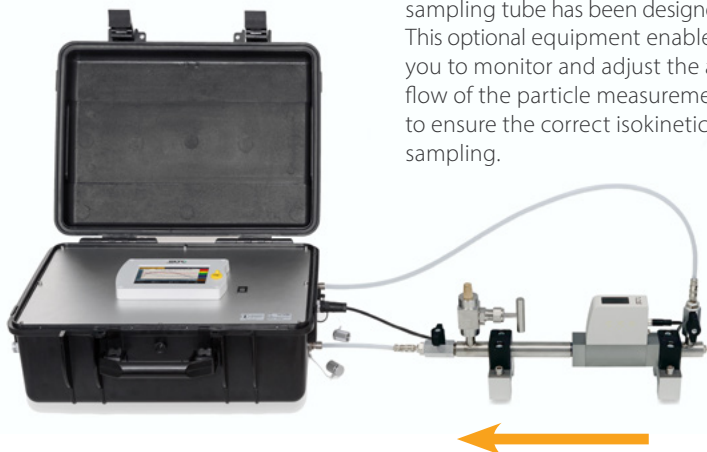

Applications

- ✓ Air quality measurements in medical, pharmaceutical, food and beverage applications
- ✓ Compressed air quality audits in regards to the ISO 8573-1
- ✓ Point-of-use measurements to ensure process safety and quality in all applications
- ✓ Monitoring of high tech applications with strict air purity requirements

Create Compressed Air Quality Reports

The S600 enables users to create powerful PDF reports directly on site. The reports are following the recommendations stated in the ISO 8573, additionally customer related data as well as service provider details can be entered on-screen, making it even easier to perform audits and to create meaningful reports.

PDF reports can be created from any recordings on the device and are copied on the fly to a connected USB drive for direct print-outs.

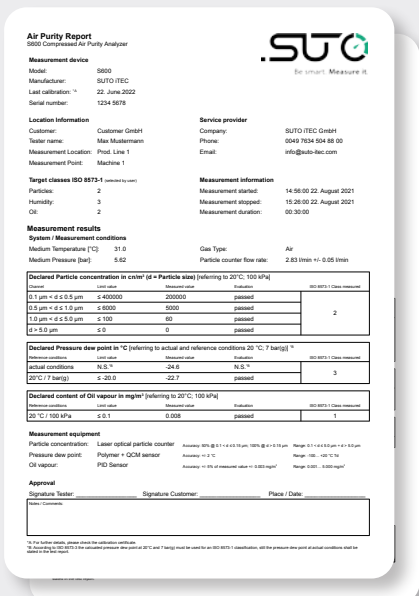



ISO 8573-1 Compressed Air Classes

ISO 8573-1:2010 is the main publication of the ISO 8573 series of standards, because it contains the permissible amount of contaminants per cubic meter of compressed air is fixed.

Class	Particle Concentration			Pressure Dew Point	Oil Concentration
	cn/m ³			°C (°F)	mg/m ³
	0.1 < d ≤ 0.5 μm	0.5 < d ≤ 1.0 μm	1.0 < d ≤ 5.0 μm		
0	As specified by the equipment user or supplier and more stringent than class 1				
1	≤ 20,000	≤ 400	≤ 10	≤ -70 (94.0)	≤ 0.01
2	≤ 400,000	≤ 6,000	≤ 100	≤ -40 (-40.0)	≤ 0.1
3	not specified	≤ 90,000	≤ 1,000	≤ -20 (-4.0)	≤ 1
4	not specified	not specified	≤ 10,000	≤ +3 (+37.4)	≤ 5
5	not specified	not specified	≤ 100,000	≤ +7 (+45.6)	> 5
6	x	x	x	≤ +10 (+50.0)	x

Why should you focus on your ISO 8573-1 specifications?

Certain industries like the pharmaceutical and food industry requires high-quality compressed air. By meeting the ISO 8573-1 standard requirements you can:

- ✔ **Ensure Process and Product Safety:**
 Potential incidents, like contaminants meeting food via water and oil, can create safety concerns and unreliable processes.
- ✔ **Avoid Production Failures and Poor Quality Finishes:**
 Contaminants mixing with applications effect product results.
- ✔ **Prevent production downtime:**
 Processes and machines are stopped to find and eliminate the contamination issues.

Dimensions

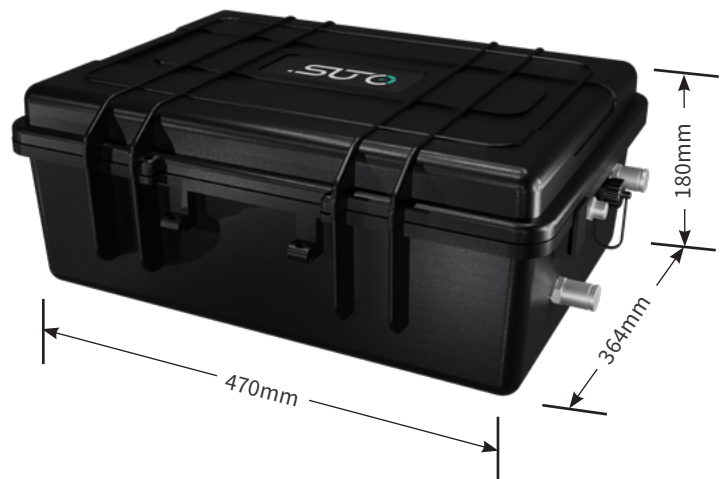



Technical Data

Measurement

Particle concentration

Accuracy	Counting Efficiency according ISO 21501-4 30 ... 70 % of d > 0.1 µm 90 ... 110 % of d ≥ 0.3 µm
----------	--

Selectable units	cn/m ³ , cn/ft ³
------------------	--

Measuring range	0.1 < d ≤ 0.5 µm
	0.5 < d ≤ 1.0 µm
	1.0 < d ≤ 5.0 µm
	5.0 µm < d

Sensor	Laser optical particle counter
--------	--------------------------------

Sampling rate	1 min.
---------------	--------

Flow rate	2.83 l/min
-----------	------------

Pressure Dew Point

Accuracy	± 1 °C Td (0 ... 20 °C Td)
	± 2 °C Td (-70 ... 0 °C Td)
	± 3 °C (-100 ... -70 °C Td)

Selectable units	°C, °F
------------------	--------

Measuring range	-100 ... +20 °C Td
-----------------	--------------------

Sensor	QCM + Polymer
--------	---------------

Response time (t90)	-20 °C Td -> -60 °C Td = < 240 sec
	-60 °C Td -> -20 °C Td = < 30 sec @ 4 l/min

Oil vapor

Accuracy	5 % of value +/- 0.003 mg/m ³
----------	--

Detection limit	0.003 mg/m ³
-----------------	-------------------------

Resolution	0.001 mg/m ³
------------	-------------------------

Selectable units	mg/m ³
------------------	-------------------

Measuring range	0.001 ... 5.000 mg/m ³
-----------------	-----------------------------------

Sensor	PID (Photoionisation detector)
--------	--------------------------------

UV lamp lifetime	1 year or 6000 working hours, whichever comes first
------------------	---

Sampling rate	1 sec.
---------------	--------

Pressure

Accuracy	0.5 % FS
----------	----------

Measuring range	0.1 ... 1.6 MPa(g)
-----------------	--------------------

Sensor	Piezo resistive sensor
--------	------------------------

Temperature

Accuracy	± 0.3 °C
----------	----------

Measuring range	-30 ... +70 °C
-----------------	----------------

Sensor	Pt100
--------	-------

Reference conditions

Selectable conditions	ISO1217 20 °C 1000 mbar
-----------------------	-------------------------

Signal / Interface & Supply

Fieldbus

Protocol	Modbus/TCP
----------	------------

Update rate	1 / sec.
-------------	----------

Power Supply

Voltage supply	Mains supply adapter (AC/DC)
	Input: 100 ... 240 VAC, 50/60 Hz, 1.4 A
	Output: 24 VDC, 2.5 A, 60 W max.

Current consumption	1.4 A
---------------------	-------

Interface

USB	USB Micro with OTG support
-----	----------------------------

LTE/4G USB	USB Port for 4G/LTE Modem
------------	---------------------------

General data

Configuration

Others	Device comes pre-configured Configuration can be done via on-screen touch
--------	--

Display

Integrated	Touchscreen, Size: 5", Resolution: 800 x 480 px
------------	---

Data Logger

Storage	100 mio. values
---------	-----------------

Report	Integrated report generator for PDF export
--------	--

Material

Process connection	Brass nickel-plated, FKM
--------------------	--------------------------

Housing	PC + ABS, Al alloy
---------	--------------------

Miscellaneous

Electrical connection	2-Pin, push-pull socket
-----------------------	-------------------------

Protection class	IP54 (cover lid closed)
------------------	-------------------------

Approvals	CE
-----------	----

Process connection	Micro quick connector, full passthrough, male (1.5 m hose with coupling included)
--------------------	---

Weight	9.8 kg
--------	--------

Operating conditions

Medium	Compressed Air, Nitrogen N ₂ , Carbon dioxide CO ₂ (software setting)
--------	---

Medium quality	ISO 8573-1: 4.4.4 or better
----------------	-----------------------------

Medium temperature	0 ... +40 °C
--------------------	--------------

Medium humidity	Medium humidity < 40 % rH, no condensation
-----------------	--

Operating pressure	0.3 ... 1.5 MPa(g)
--------------------	--------------------

Ambient temperature	0 ... +50 °C
---------------------	--------------

Ambient humidity	0 ... 90 % rH
------------------	---------------

Storage temperature	-10 ... +70 °C
---------------------	----------------

Transport temperature	-10 ... +70 °C
-----------------------	----------------

Technical Data

Isokinetic Sampling Device

Measurement

Isokinetic Sampling Device

Measuring unit	Measuring unit Sampling pipe with integrated isokinetic sampling tube, flow regulation and control by integrated flow sensor, to be used for particle measurements according to ISO 8573-4
Flow meter unit	Thermal mass flow meter (only for isokinetic flow setup, no system flow measurement)
Sensor	Thermal mass flow sensor
Accuracy	3 % o. RDG

Signal Interface & Supply

Connection	Communication to S600 (cable included)
Update rate	1 / sec.

General data

Material

Process connection	Brass nickel-plated, FKM
Housing	PC + ABS, Al alloy
Main unit	Al alloy
Isokinetic tube	Stainless steel 1.4404 (SUS 316L)

Miscellaneous

Electrical connection	M8
Protection class	IP54
	IEC 61326-1
Process connection	Micro quick connector, full passthrough, male (1.5 m hose with coupling included)

Operating conditions

Medium	Compressed Air, Nitrogen N ₂ , Carbon dioxide CO ₂ (software setting)
Medium quality	ISO 8573-1: 4.4.4 or better
Medium temperature	0 ... + 40 °C
Medium humidity	Medium humidity < 40 % rH, no condensation
Operating pressure	0.3 ... 1.5 MPa(g)
Ambient temperature	0 ... +50 °C
Ambient humidity	0 ... 90 % rH
Storage temperature	-10 ... + 70 °C
Transport temperature	-10 ... + 70 °C

Dimensions Isokinetic Sampling Device

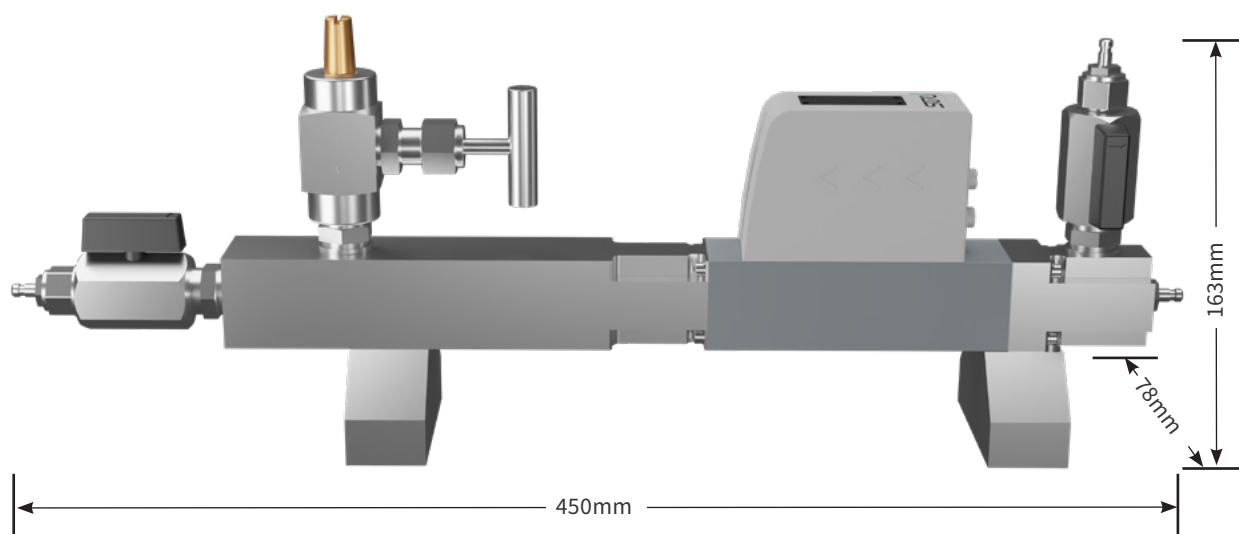



Ordering

Please use the following tables to assist in placing your order with our sales staff.

S600 Portable Compressed Air Purity Analyzer (Portable Version)

Order No.	Description
KA66P5600600	<p>Touch screen interface, data logger, guided measurement, PDF report generator, USB port and Ethernet port with Modbus/TCP Particle d: $0.1 < d \leq 0.5, \mu\text{m}$ $0.5 < d \leq 1.0 \mu\text{m}$, $1.0 < d \leq 5.0 \mu\text{m}$, $d > 5.0 \mu\text{m}$ Dew point: $-100 \dots +20 \text{ }^\circ\text{C Td}$ Oil vapor: $0.001 \dots 5.000 \text{ mg/m}^3$</p> <p><u>Including:</u></p> <ul style="list-style-type: none">• Portable Compressed Air Purity Analyzer in a hand carry case with handle and shoulder belt• USB OTG memory stick• Purge filter for pre-measurement (test kit)• Power supply, 230 VAC / 24 VDC 50/60 Hz• 2 x Connection hose 1.5 m, one end quick coupling, one end compressed air coupling• Certificate of calibration• Operation and instruction manual
KA66000A1670	USB 4G dongle for S551/S600, including S4A software

Isokinetic Sampling Device

Order No.	Description
KA66A5540600	<p>Isokinetic sampling device for particle measurement according to ISO 8573</p> <p><u>Including:</u></p> <ul style="list-style-type: none">• Isokinetic sampling pipe• Flow sensor mounted on pipe• Certificate of calibration• Connection cable to S600• Connection hose 150 mm, both ends quick coupling• Connection hose 700 mm, both ends quick coupling• Connection hose 1.5 m, one end quick coupling, one end compressed air coupling• Transport case to carry the device, hoses and cables



www.kompauto.com



sales@kompauto.com



S601



Stationary Compressed Air Purity Monitor



ALL IN ONE
Dew point, particle and oil vapor



TOUCH SCREEN
5" large color LCD



INDUSTRIAL DESIGN
For outdoor applications



PRECISION
Accurate measurements



COMPACT DESIGN
Can be installed anywhere



Benefits

- ✓ All-in-one device measures particle concentration, dew point and oil vapor
- ✓ Measures additionally the temperature and pressure
- ✓ Software guided measurement makes it easy to generate reliable results
- ✓ Real time information can be retrieved from the S601 by SCADA systems via MODBUS outputs
- ✓ Compact design and easy setup, just connect the unit to power and the compressed air supply

Constant Measurement — 24/7 Monitoring

The S601 combines three major quality measurements into a single wall mountable device. Optimized to be used as Plug & Play system, the S601 helps users to identify the air quality at a glance.

The robust cabinet makes it well suited for rough industrial applications.

A stainless steel cabinet is offered on request, which is suited for pharmaceutical and medical applications.

The S601 combines the latest sensor technology and a time-saving setup into a one of its kind multi-tool. Mount it, power it, connect it and measure. Trust us, it is that easy.

Monitoring of All Relevant Contaminants



Particle Concentration Measurement

$0.1 < d \leq 0.5 \mu\text{m}$ / $0.5 < d \leq 1.0 \mu\text{m}$ / $1.0 < d \leq 5.0 \mu\text{m}$ / $5.0 \mu\text{m} < d$



Dew Point Measurement

-100 ... +20 °C Td



Oil Vapor Measurement

0.001... 5.000 mg/m³

ISO 8573-1 Classification

Alarm Management
Modbus RTU / TCP
Monitoring Software

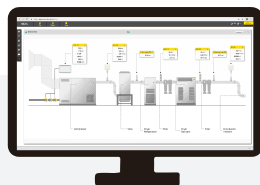

Environment

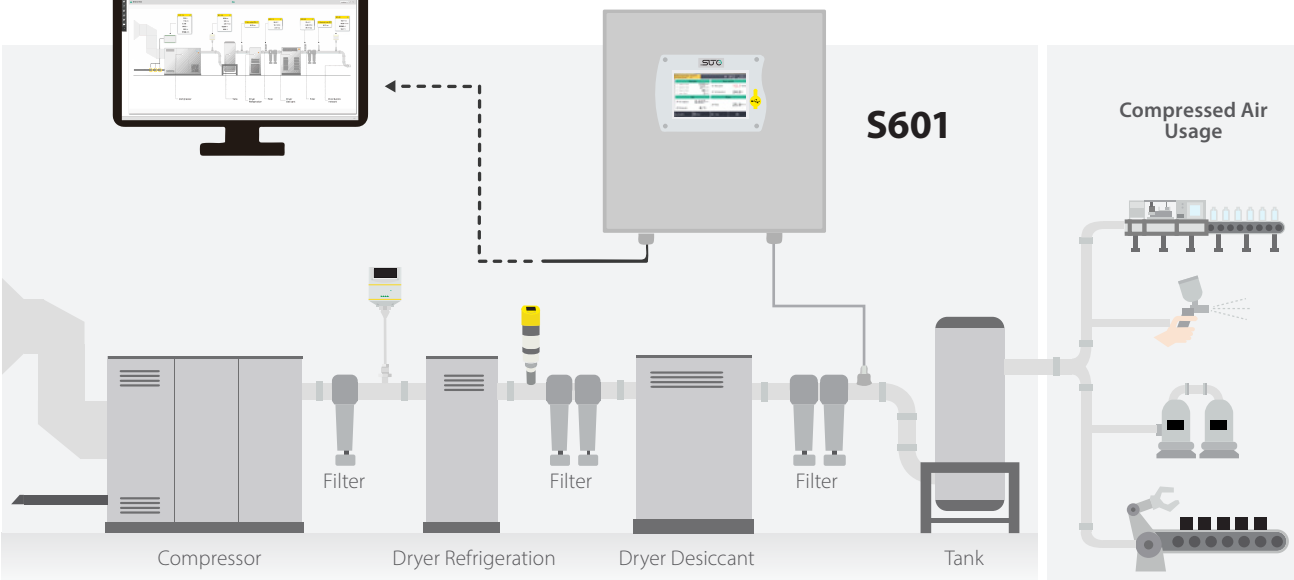



Various Applications

- ✓ Air quality measurements in medical, pharmaceutical, food and beverage applications
- ✓ Compressed air quality audits in regards to the ISO 8573-1
- ✓ Point-of-use measurements to ensure process safety and quality in all applications
- ✓ Monitoring of high tech applications with strict air purity requirements

5 in 1 Measuring Device

The S601 is the stationary multi-tool for compressed air purity measurements. It measures, records and validates quality parameters like particles, dew point, oil vapor contents, temperature and the pressure of compressed air systems. It offers different signal outputs to seamlessly integrate it into your system. The integrated logger stores the recorded values safely.



Particle Concentration Measurement

- Measurement methods according to ISO 8573 standards
- Latest laser detection technology
- Smallest particle size 30 ... 70 %, next bigger sizes 90 ... 110 % per ISO 21501-4



Integrated Data Logger

- Integrated data logger records all channels in parallel for later analysis
- 5" touchscreen allows you to interact with the device on site
- There is no need for a PC to manage the device



Oil Vapor Measurement

- Latest photoionisation detector (PID) with self-calibration
- Wide range of oil vapor concentrations
- High precision with 5 % of reading \pm 0.003 mg/m³ accuracy



Dew Point Measurement

- Large ranges thanks to the unique multiple sensor technology
- Long-term stable and well-proven measurement methods
- Outstanding precision with a high accuracy over the full range from -100 to +20 °C Td



Pressure Measurement

- State of the art sensor technology
- Additional quality data about the compressed air system

Modular Concept

The S601 is based on a modular concept which enables the client to decide which type of measurement needs to be performed.

This makes the S601 customizable and flexible to offer the end-user the best suited instrument to finish the desired measurement tasks.







ISO 8573-1 Compressed Air Classes

ISO 8573-1:2010 is the main publication of the ISO 8573 series of standards, because it contains the permissible amount of contaminants per cubic meter of compressed air is fixed.

Class	Particle Concentration			Pressure Dew Point	Oil Concentration
	cn/m ³			°C (°F)	mg/m ³
	0.1 < d ≤ 0.5 μm	0.5 < d ≤ 1.0 μm	1.0 < d ≤ 5.0 μm		
0	As specified by the equipment user or supplier and more stringent than class 1				
1	≤ 20,000	≤ 400	≤ 10	≤ -70 (94.0)	≤ 0.01
2	≤ 400,000	≤ 6,000	≤ 100	≤ -40 (-40.0)	≤ 0.1
3	not specified	≤ 90,000	≤ 1,000	≤ -20 (-4.0)	≤ 1
4	not specified	not specified	≤ 10,000	≤ +3 (+37.4)	≤ 5
5	not specified	not specified	≤ 100,000	≤ +7 (+45.6)	> 5
6	x	x	x	≤ +10 (+50.0)	x

Why should you focus on your ISO 8573-1 specifications?

Certain industries like the pharmaceutical and food industry requires high-quality compressed air. By meeting the ISO 8573-1 standard requirements you can:

- 
Ensure Process and Product Safety:
 Potential incidents, like contaminants meeting food via water and oil, can create safety concerns and unreliable processes.
- 
Avoid Production Failures and Poor Quality Finishes:
 Contaminants mixing with applications effect product results.
- 
Prevent production downtime:
 Processes and machines are stopped to find and eliminate the contamination issues.

Dimensions

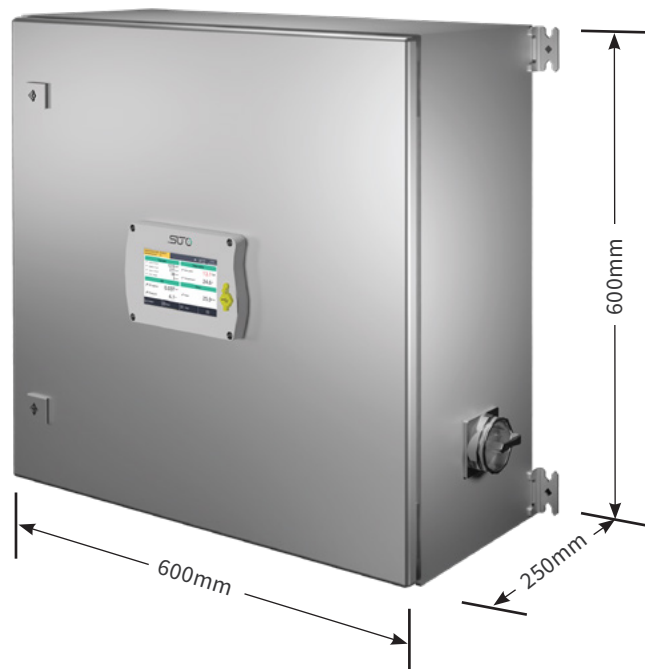



Technical Data

Measurement

Particle concentration

Counting efficiency	According ISO 21501-4	
	Option KA66000A1263: 30 ... 70 % of d > 0.1 µm 90 ... 110 % of d ≥ 0.3 µm	Option KA66000A1260: 30 ... 70 % of d > 0.3 µm 90 ... 110 % of d ≥ 0.45 µm

Selectable units cn/m³, cn/ft³

Measuring range	Option KA66000A1263: 0.1 < d ≤ 0.5 µm 0.5 < d ≤ 1.0 µm 1.0 < d ≤ 5.0 µm 5.0 µm < d	Option KA66000A1260: 0.3 < d ≤ 0.5 µm 0.5 < d ≤ 1.0 µm 1.0 < d ≤ 5.0 µm 5.0 µm < d
-----------------	---	---

Sensor Laser optical particle counter

Sampling rate 1 min.

Flow rate 2.83 l/min

Pressure Dew Point

Accuracy	± 1 °C Td (0 ... 20 °C Td)
	± 2 °C Td (-70 ... 0 °C Td)
	± 3 °C (-100 ... -70 °C Td)

Selectable units °C, °F

Measuring range -100 ... +20 °C Td

Sensor QCM + Polymer

Response time
(t₉₀) -20 °C Td -> -60 °C Td = < 240 sec
-60 °C Td -> -20 °C Td = < 30 sec
@ 4 l/min

Oil vapor

Accuracy 5 % of value +/- 0.003 mg/m³

Detection limit 0.003 mg/m³

Resolution 0.001 mg/m³

Selectable units mg/m³

Measuring range 0.001 ... 5.000 mg/m³

Sensor PID (Photoionisation detector)

UV lamp lifetime 1 year or 6000 working hours, whichever comes first

Sampling rate 1 sec.

Pressure

Accuracy 0.5 % FS

Measuring range 0.1 ... 1.6 MPa(g)

Sensor Piezo resistive sensor

Temperature

Accuracy ± 0.3 °C

Measuring range -30 ... +70 °C

Sensor Pt100

Reference conditions

Selectable conditions ISO1217 20 °C 1000 mbar

Signal / Interface & Supply

Fieldbus

Protocol Modbus/TCP

Update rate 1 / sec.

Alarm output

Relay 2 x Changeover Relay (freely programmable)

Rating 230 VAC, 3A

Power Supply

Voltage supply 100 ... 240 VAC, 50/60 Hz

Current consumption 50 VA

Interface

USB USB Micro with OTG support

General data

Configuration

Others Device comes pre-configured
Configuration can be done via on-screen touch

Display

Integrated Touchscreen, Size: 5", Resolution: 800 x 480 px

Data Logger

Storage 100 mio. values

Material

Process connection Brass nickel-plated, FKM

Housing Sheet steel, powder coated cabinet

Miscellaneous

Electrical connection AC Clamp Terminals, M12, RJ45

Protection class IP54 (cover lid closed)

Approvals CE

Process connection Micro quick connector, full passthrough, male (1.5 m hose with coupling included)

Weight 15 kg

Operating conditions

Medium Compressed Air, Nitrogen N₂, Carbon dioxide CO₂ (software setting)

Medium quality ISO 8573-1: 4.4.4 or better

Medium temperature 0 ... + 40 °C

Medium humidity Medium humidity < 40 % rH, no condensation

Operating pressure 0.3 ... 1.5 MPa(g)

Ambient temperature 0 ... +50 °C

Ambient humidity 0 ... 90 % rH

Storage temperature -10 ... +70 °C

Transport temperature -10 ... +70 °C

Ordering

Please use the following tables to assist in placing your order with our sales staff.

S601 Stationary Compressed Air Purity Monitor

Order No.	Description
-----------	-------------

KA66D5000601	S601 Stationary Compressed Air Purity Monitor Touch screen interface, data logger , metal cabinet for wall mounting Supply voltage 100 ... 240 V AC, Inlet pressure 0.3 .. 1.5 MPa*
--------------	---

KA66000A1670	USB 4G dongle, including S4A software
--------------	---------------------------------------

KA66A5540131	4G USB Dongle protection case, with extension cable 2 m and M12 Connector
--------------	---

***Including:**

- Dew point measurement rig -100 ... +20 °C Td
- 2 m PTFE hose
- 1.5 m PTFE hose with quick connector
- Purge unit for measuring point cleaning
- USB OTG memory stick
- S4A Software for logger read out and analysis
- 1 x PTFE hose adapter
- Certificate of calibration

Particle counter

KA66000A1260	Integrated particle counter rig, $0.3 < d \leq 0.5 \mu\text{m}$, $0.5 < d \leq 1.0 \mu\text{m}$, $1.0 < d \leq 5.0 \mu\text{m}$, 2.83 l/min
--------------	--

KA66000A1263	Integrated particle counter rig, $0.1 < d \leq 0.5 \mu\text{m}$, $0.5 < d \leq 1.0 \mu\text{m}$, $1.0 < d \leq 5.0 \mu\text{m}$, 2.83 l/min
--------------	--

Oil vapor measurement

KA66000A1267	Integrated oil vapor sensor rig, 0.001 ... 5.000 mg/m ³
--------------	--

Remote Connection

By connecting a 4G/LTE modem to the designated M12 port, S601 can be monitored remotely through S4A software.



www.kompauto.com



sales@kompauto.com



S605



Portable Breathing Air Quality Analyzer



ALL IN ONE
O₂, CO₂, CO, H₂O,
Oil, Pressure



PLUG & PLAY
Simple connection
to your system



PORTABLE DEVICE
Can be carried
with one hand



**HIGH
PRECISION**
Accurate
measurements



**COMPACT
DESIGN**
Simple and
efficient handling



**COMMUNICATION
INTERFACE**
Modbus TCP/RTU,
4G-Modem



Benefits

- ✓ All-in-one Instrument measures O₂, CO₂, CO, Dew Point and Oil Vapor simultaneously in the breathing air
- ✓ Portable and lightweight measuring device in a robust carry case
- ✓ Testing quality of breathing air according to national and international standards
- ✓ Software guided measurement makes it easy to generate reliable results and reports
- ✓ Only one gas inlet for all parameters
- ✓ Integrated data logger saves data for later analysis

Real-time breathing air quality measurements

The purity of the breathing air is vital for the operators health and safety. It is essential to have regular purity checks of the supplied air.

The SUTO S605 Portable Breathing Air Quality Analyzer, measures O₂, CO₂, CO, Dew Point, Oil Vapor and Pressure as defined in the breathing air purity standards and instantly shows the measured values on the touch screen display.

The robust design, quick sensor response times, and a user-friendly user interface ensures reliable and quick measurements, resulting in maximum protection for the people using air for breathing applications.

It is smarter, faster and more convenient than the traditional methods.

Monitoring of all breathing air parameters

O₂	Oxygen	CO	Carbon Monoxide
CO₂	Carbon Dioxide	H₂O	Humidity
According to all relevant national and international standards		OIL	Oil Residues

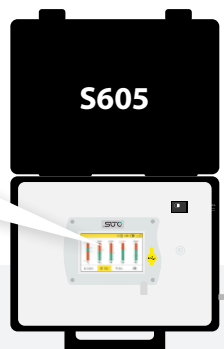
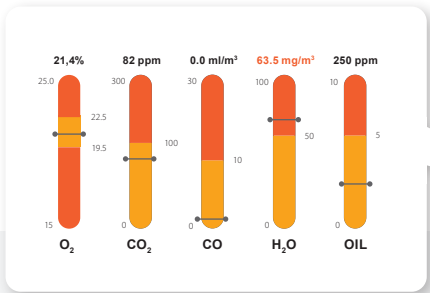

4G Remote Connection to S4A Monitoring Software

Breathing Air

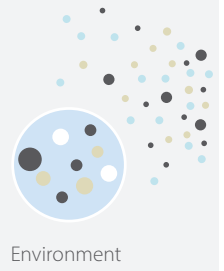

Environment



Compressor



Purification



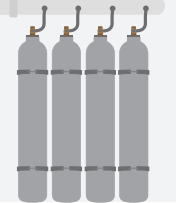

Air Receiver Tank



Reserve Air System



7 in 1 Measurement Device

- O₂** **Oxygen Measurement**
For safety reasons, it is recommended to measure the oxygen level in the breathing air. The optical oxygen sensor monitors the O₂ content and indicates deviations from the standard concentration.
- CO₂** **Carbon Dioxide Measurement**
The intake air may also be exposed to increased concentration of carbon dioxide. Filter material used in compressed air can adsorb, but also release CO₂. The gas is measured by the NDIR sensor to avoid extreme concentrations above 1000 ppm.
- CO** **Carbon Monoxide Measurement**
The compressor intake air may be contaminated with CO due to nearby combustion engines or heating systems. Carbon monoxide is a toxic and life-threatening gas which will be monitored accurately by an electrochemical sensor.
- H₂O** **Humidity Measurement**
High humidity can cause corrosion and in severe cases lead to bursting air containers. In cold environment, it can freeze and block the air supply. The integrated dew point sensor is crucial to check the proper water removal of the dryers and filters.
- OIL** **Oil Vapor Measurement**
Atmospheric oil vapor contained in industrial air environment can get into the system through the compressor intake. Compressed into the breathing air, the oil contaminants can cause health issues. The state-of-the-art sensor technology detects the oil contaminants immediately.
-  **Pressure Measurement**
The pressure sensor provides additional pressure data about the compressed air system using state of the art sensor technology.
-  **Integrated Data Logger**
The integrated data logger records all channels in parallel for later analysis. The 5" touchscreen allows you to interact with the device on site. There is no need for a PC to manage the device.

Applications

Operators of breathing air systems are required to fill respiratory air in line with international standards such as EN 12021 or CFSR 1910.134(d). Potential hazards due to impurities in the breathing air can have consequences which endanger health or which are even life-threatening.

Regular checks with the Breathing Air Quality Analyzer S605 is an indispensable part for a safe operation.

Remote Connection

By connecting a 4G/LTE modem to the designated USB port, S605 can be monitored remotely through S4A software.



Create Breathing Air Quality Reports

The S605 enables users to create powerful PDF reports directly on site. Customer related data as well as service provider details can be entered on-screen, making it even easier to perform audits and to create meaningful reports.

PDF reports can be created from any recordings on the device and are copied on the fly to a connected USB drive for direct print-outs.

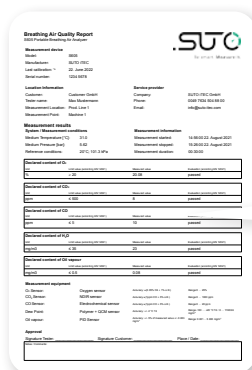

Measurement results		Measurement information	
System / Measurement conditions			
Medium Temperature [°C]:	31.0	Measurement started:	14:56:00 22. August 2021
Medium Pressure [bar]:	5.62	Measurement stopped:	15:26:00 22. August 2021
Reference conditions:	20°C; 101.3 kPa	Measurement duration:	00:30:00
Declared content of O₂			
Unit	Limit value (according EN 12021)	Measured value	Evaluation (according EN 12021)
%	≥ 20	20.08	passed
Declared content of CO₂			
Unit	Limit value (according EN 12021)	Measured value	Evaluation (according EN 12021)
ppm	≤ 500	8	passed
Declared content of CO			
Unit	Limit value (according EN 12021)	Measured value	Evaluation (according EN 12021)
ppm	≤ 15	10	passed
Declared content of H₂O			
Unit	Limit value (according EN 12021)	Measured value	Evaluation (according EN 12021)
mg/m ³	≤ 5	23	passed
Declared content of Oil vapour			
Unit	Limit value (according EN 12021)	Measured value	Evaluation (according EN 12021)
mg/m ³	≤ 0.5	0.08	passed



Relevant standards for breathing air

Relevant standards including BS EN 12021, DEF STAN 68-284, OSHA, CSA and BS 8478 require adherence to specific limits of constituents in breathing air. Here some examples of the required for industrial breathing air:

Contaminant	Europe	China	USA	Canada
Standard	EN 12021	GB/T 31975-2015	CFSR	CSA
O₂	>20 %	19.5 - 23.5 %	19.5 - 23.5 %	20 - 22 %
CO₂	500 ppm	≤ 1000 mL/m ³	1,000 ppm	500 ml/m ³
CO	5 ppm	≤ 10 mL/m ³	10 ppm	5 ml/m ³
H₂O	PDP: < -11 °C 1) H ₂ O: <35 mg/m ³ 2) H ₂ O: <25 mg/m ³	ADP: ≤ -45.6 °C	---	---
VOC (Oil Vapor)	0.5 mg/m ³	≤ 5.0 mg/m ³ (Oil mist and particle)	5 mg/m ³	1 mg/m ³
Odor	no	no	no	no

Dimensions

Due to the small dimensions of the robust and light carry case, the S605 can be easily transported anywhere.

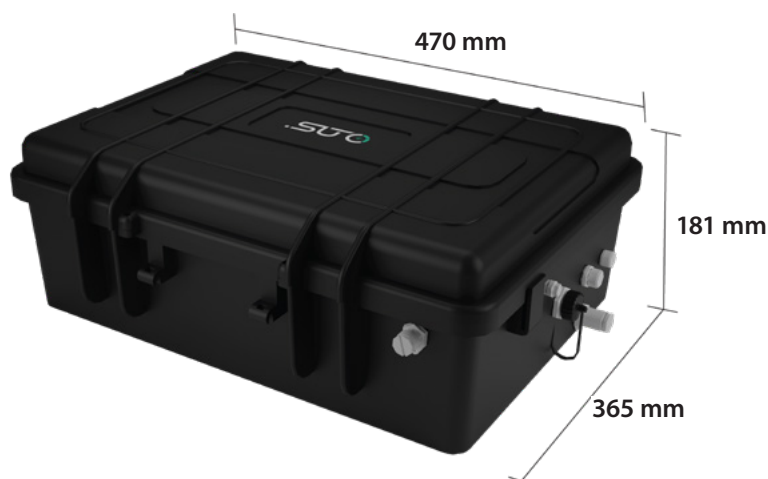

Why is breathing air quality testing important?



- ✓ It protects the health, safety and well-being of your employees and people who are on your premises.
- ✓ It ensures that your compressor, products and personnel are protected from airborne volatile organic compounds (VOCs) as well
- It ensures that your business complies with national and international regulatory standards for breathing air quality.
- ✓
- ✓ It ensures that your compressed air and work environment have safe levels of oxygen, lubricants, oil, odor, taste, carbon dioxide, carbon monoxide and water.



Technical Data

Measurement

Oxygen O₂

Accuracy	±(0.05 % O ₂ + 1 % o.R.)
Measuring range	0 ... 25 %
Resolution	0.01 %
Sensor	Optical oxygen sensor

Carbon Dioxide CO₂

Accuracy	±(25 ppm CO ₂ + 1 % o.R.)
Measuring range	0 ... 1000 ppm
Resolution	1 ppm
Sensor	NDIR sensor

Carbon Monoxide CO

Accuracy	±(1 ppm CO + 5 % o.R.)
Measuring range	0 ... 20 ppm
Resolution	0.1 ppm
Sensor	Electrochemical sensor

Humidity H₂O

Accuracy	±2 °C Td
Measuring range	-100 ... +20 °C Td / 0 ... 17458.6 mg/m ³
Resolution	0.1 mg/m ³
Sensor	QCM + Polymer

Oil Vapor

Accuracy	5 % of reading ± 0.003 mg/m ³
Measuring range	0.001 ... 5.000 mg/m ³ (Based on 1000 hPa(a), 20 °C, 0 % relative humidity)
Resolution	0.001 mg/m ³
Sensor	Photo ionization detector

Oil Mist and Particle

Accuracy	15 % of reading ± 0.1 mg/m ³
Measuring range	0.0 ... 5.0 mg/m ³ (Based on 1000 hPa(a), 20 °C, 0 % relative humidity)
Resolution	0.1 mg/m ³
Sensor	Oil mist and particle sensor

Pressure

Accuracy	0.5 % FS
Measuring range	0 ... 16 bar(g)
Resolution	0.01 bar
Sensor	Piezo resistive pressure sensor

Signal / Interface & Supply

Fieldbus

Protocol	Modbus/RTU (RS485) Modbus/TCP (Ethernet)
Update rate	1 / sec.

Power supply

Voltage supply	18-32 VDC, 20 W Battery
Current consumption	1.4 A

Interface

USB	USB Micro with OTG support
4G/LTE USB	USB Port for 4G/LTE Modem

General data

Configuration

Others	Device comes pre-configured Configuration can be done via on-screen touch
--------	---

Display

Integrated	5" color touch screen
------------	-----------------------

Data Logger

Storage	100 million measurement values
Report	Integrated report generator for PDF export

Material

Process connection	6 mm quick connector
Housing	PC, Al alloy

Miscellaneous

Electrical connection	M12, USB-C, RJ45
Protection class	IP54
Water Inlet	6 mm connector
Dimensions	470 x 365 x 181 mm
Weight	11 kg

Approvals

EMC	FCC, CE
-----	---------

Operating conditions

Measuring Medium	Compressed breathing air
Sample Flow Rate	6 LPM@4 MPa(g), depends on input pressure
Sample rate	1 sample/sec
Medium temperature	0 ... +45 °C
Medium humidity	Medium humidity < 40 % rH, no condensation
Inlet Pressure	0.4 ... 1.5 MPa(g), External pressure reducer allow up to 35 MPa process pressure
Ambient temperature	0 ... +50 °C
Ambient humidity	0 ... 90 % rH
Storage temperature	-10 ... +50 °C
Transport temperature	-10 ... +50 °C



Ordering

Please use the following tables to assist in placing your order with our sales staff.

S605 Portable Breathing Air Quality Analyzer

Order No.	Description
KA66P5600605	S605 Portable Breathing Air Quality Analyzer, touch screen interface, data logger, guided measurement, PDF report generator (with oil vapor sensor refer to Europe, USA, Canada standards) *
KA66P5601605	S605 Portable Breathing Air Quality Analyzer, touch screen interface, data logger, guided measurement, PDF report generator (with oil mist and particle sensor refer to China standards)*
KA66000A1670	USB 4G dongle, including S4A software

* Including:

- Hand carry case with handle and shoulder belt
- USB OTG memory stick
- Purge filter for pre-measurement (test kit)
- Power adapter with USB type-C connector and cable included 60 W 20 V/3.25 A
- Connection hose 1.5 m, one end quick coupling, one end compressed air coupling
- M12 connector
- Filling bottle
- Certificate of calibration
- Operation and instruction manual

Accessories

Order No.	Description
KA66A5540602	Purity test kit consisting of zero filters for oil vapor, particles, and a desiccant cartridge for low dew point creation
KA66A5541203	Oil vapor zero filter, 1.5 MPa max, with quick connectors at both ends
KA66A5541204	Particle zero filter, 1.5 MPa max, with quick connectors at both ends
KA66A5541205	Dew point test kit for low dew point generation, with quick connectors at both sides
KA66A6040004	Pressure reducer, inlet pressure 0-30 MPa, outlet pressure 0.6 Mpa
KA66A6040005	Pressure reducer, inlet pressure 0-40 MPa, outlet pressure 0.6 Mpa

Service and Calibration

Order No.	Description
KA66R2000605	S605 General service and re-calibration <ul style="list-style-type: none"> • General inspection of the unit • Replacement of tubes and fittings • Cleaning of components • Calibration O₂, CO₂, CO, dew point sensor and oil vapor • Assembly and test of unit • Calibration Certificate

Exchange sensors

KA66R2000620	CO exchange sensor unit S605/S606
KA66R2000621	CO ₂ exchange sensor unit S605/S606
KA66R2000622	O ₂ exchange sensor unit S605/S606
KA66R2000623	Oil mist and particle sensor exchange unit S605/S606
KA66R2000624	Oil vapor sensor exchange unit S605/S606
KA66R2000625	Dew Point sensor exchange unit S605/S606



www.kompauto.com



sales@kompauto.com



S606



Stationary Breathing Air Quality Analyzer



ALL IN ONE
O₂, CO₂, CO,
Dew Point,
Oil Vapor, Pressure



**RELIABLE
WARNING**
Alarms can be
programmed



EASY HANDLING
Clear and user friendly
user guidance



**HIGH
PRECISION**
Accurate
measurements



**ROBUST
DESIGN**
Suitable for harsh
industrial condition



**COMMUNICATION
INTERFACE**
Modbus TCP/RTU,
4G-Modem



Benefits

- ✓ All-in-one Instrument measures O₂, CO₂, CO, Dew Point and Oil Vapor simultaneously in the breathing air
- ✓ 24/7 permanent breathing air monitoring with programmable alarm settings
- ✓ Testing quality of breathing air according to national and international standards
- ✓ Compressed air connection via 6 mm tube
- ✓ Only one gas inlet for all parameters
- ✓ Integrated data logger saves data for later analysis

Contant breathing air quality monitoring

When it comes to breathing air, the health and safety of humans has highest priority. Still fatal accidents have occurred in the past due to the contaminated air.

To ensure the highest safety when breathing air is supplied, an online measurement system is required. Traditional breathing air analyzes have been carried out, by taking samples and later analyze them in an external laboratories. Online systems have been rarely available and often did come with very high investments and intense process modifications.

SUTO is here to change that. The S606 Breathing Air Quality Analyzer combines latest sensor technology into a single Plug & Play measurement solution.

S606 constantly measures O₂, CO₂, CO, Dew Point, Oil Vapor and Pressure as defined in the breathing air purity standards and notifies users in real-time when the purity is not within the defined limits.

It is smarter, faster and more convenient than the traditional methods.

Monitoring of all breathing air parameters

O₂	Oxygen	CO	Carbon Monoxide
CO₂	Carbon Dioxide	H₂O	Humidity
According to all relevant national and international standards		OIL	Oil Residues

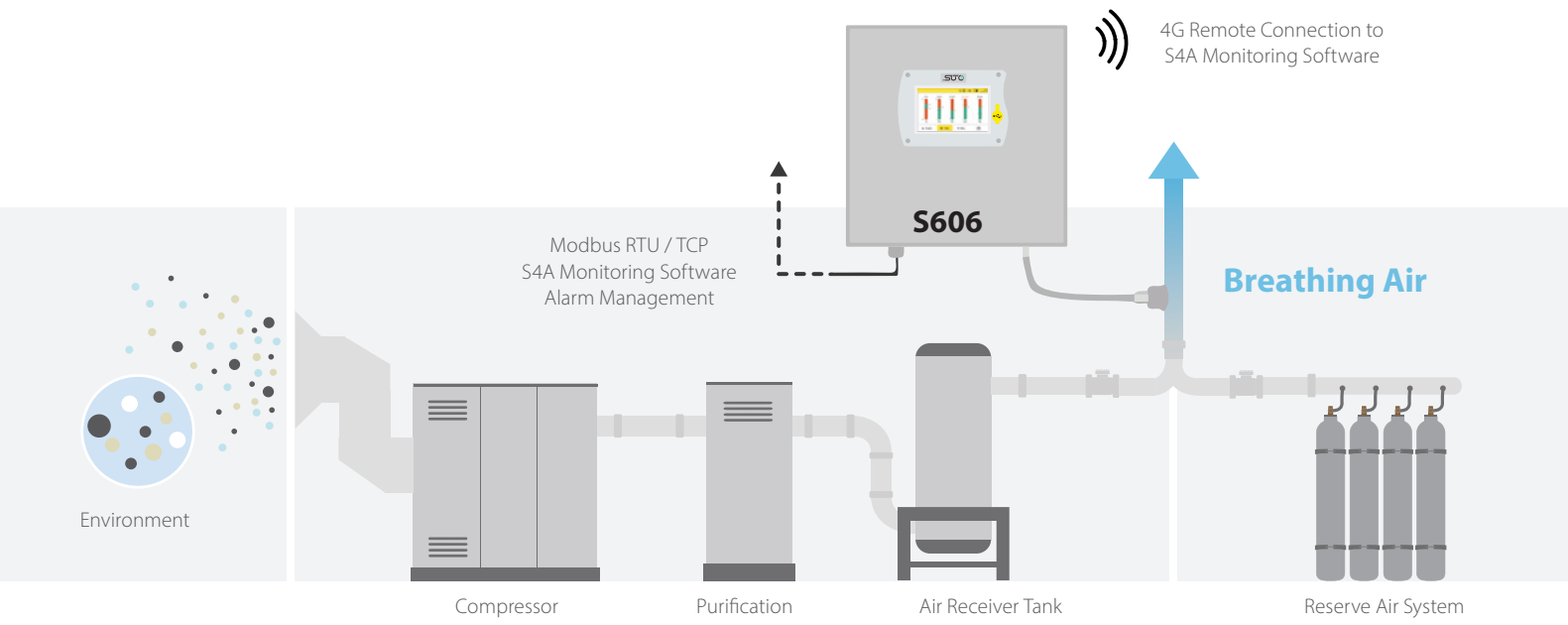



Applications

The S606 is a compact wall-mounted breathing air quality analyzer which measures all crucial breathing air parameters, to ensure that the breathing air is safe for health and the process.

Crucial Industries and Sectors rely on a reliable breathing air supply, e.g. fire fighting, diving, spray painting, chemical industry, offshore and high tech applications.

7 in 1 Measurement Device



Oxygen Measurement

For safety reasons, it is recommended to measure the oxygen level in the breathing air. The optical oxygen sensor monitors the O₂ content and indicates deviations from the standard concentration.



Carbon Monoxide Measurement

The compressor intake air may be contaminated with CO due to nearby combustion engines or heating systems. Carbon monoxide is a toxic and life-threatening gas which will be monitored accurately by an electrochemical sensor.



Oil Vapor Measurement

Atmospheric oil vapor contained in industrial air environment can get into the system through the compressor intake. Compressed into the breathing air, the oil contaminants can cause health issues. The state-of-the-art sensor technology detects the oil contaminants immediately.



Pressure Measurement

The pressure sensor provides additional pressure data about the compressed air system using state of the art sensor technology.



Integrated Data Logger

The integrated data logger records all channels in parallel for later analysis. The 5" touchscreen allows you to interact with the device on site. There is no need for a PC to manage the device.



Carbon Dioxide Measurement

The intake air may also be exposed to increased concentration of carbon dioxide. Filter material used in compressed air can adsorb, but also release CO₂. The gas is measured by the NDIR sensor to avoid extreme concentrations above 1000 ppm.



Humidity Measurement

High humidity can cause corrosion and in severe cases lead to bursting air containers. In cold environment, it can freeze and block the air supply. The integrated dew point sensor is crucial to check the proper water removal of the dryers and filters.



Remote Connection

By connecting a 4G/LTE modem to the designated M12 port, S606 can be monitored remotely through S4A software.



Relevant standards for breathing air

Relevant standards including BS EN 12021, DEF STAN 68-284, OSHA, CSA and BS 8478 require adherence to specific limits of constituents in breathing air. Here some examples of the required for industrial breathing air:

Contaminant	Europe	China	USA	Canada
Standard	EN 12021	GB/T 31975-2015	CFSR	CSA
O₂	>20 %	19.5 - 23.5 %	19.5 - 23.5 %	20 - 22 %
CO₂	500 ppm	≤ 1000 mL/m ³	1,000 ppm	500 ml/m ³
CO	5 ppm	≤ 10 mL/m ³	10 ppm	5 ml/m ³
H₂O	PDP: < -11 °C 1) H ₂ O: <35 mg/m ³ 2) H ₂ O: <25 mg/m ³	ADP: ≤ -45.6 °C	---	---
VOC (Oil Vapor)	0.5 mg/m ³	≤ 5.0 mg/m ³ (Oil mist and particle)	5 mg/m ³	1 mg/m ³
Odor	no	no	no	no

Why is breathing air quality testing and monitoring important?

- ✔ It protects the health, safety and well-being of your employees and people who are on your premises.
- ✔ It ensures that your compressor, products and personnel are protected from airborne volatile organic compounds (VOCs) as well
- ✔ It ensures that your business complies with national and international regulatory standards for breathing air quality.
- ✔ It ensures that your compressed air and work environment have safe levels of oxygen, lubricants, oil, odor, taste, carbon dioxide, carbon monoxide and water.

Dimensions

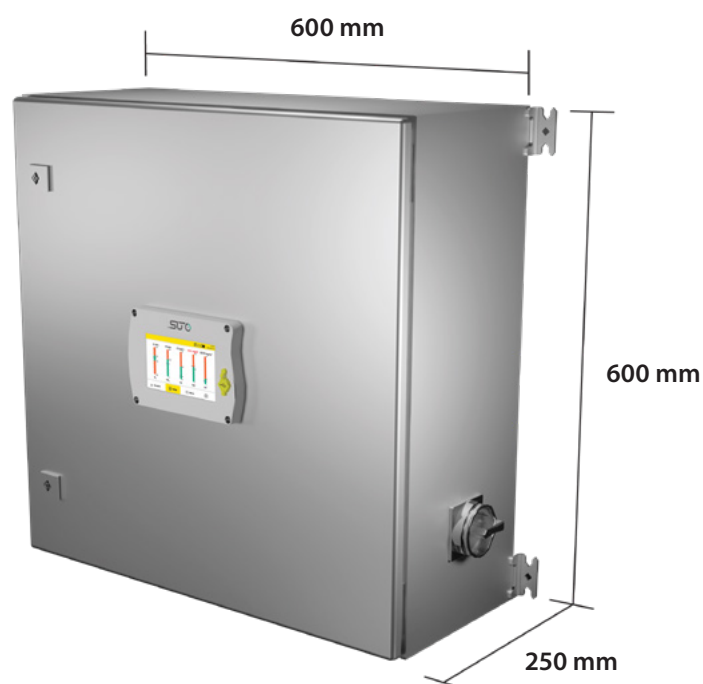



Technical Data

Measurement

Oxygen O₂

Accuracy	±(0.05 % O ₂ + 1 % o.R.)
Measuring range	0 ... 25 %
Resolution	0.01 %
Sensor	Optical oxygen sensor

Carbon Dioxide CO₂

Accuracy	±(25 ppm CO ₂ + 1 % o.R.)
Measuring range	0 ... 1000 ppm
Resolution	1 ppm
Sensor	NDIR sensor

Carbon Monoxide CO

Accuracy	±(1 ppm CO + 5 % o.R.)
Measuring range	0 ... 20 ppm
Resolution	0.1 ppm
Sensor	Electrochemical sensor

Humidity H₂O

Accuracy	±2 °C Td
Measuring range	-100 ... +20 °C Td / 0 ... 17458.6 mg/m ³
Resolution	0.1 mg/m ³
Sensor	QCM + Polymer

Oil Vapor

Accuracy	5 % of reading ± 0.003 mg/m ³
Measuring range	0.001 ... 5.000 mg/m ³ (Based on 1000 hPa(a), 20 °C, 0 % relative humidity)
Resolution	0.001 mg/m ³
Sensor	Photo ionization detector

Oil Mist and Particle

Accuracy	15 % of reading ± 0.1 mg/m ³
Measuring range	0.0 ... 5.0 mg/m ³ (Based on 1000 hPa(a), 20 °C, 0 % relative humidity)
Resolution	0.1 mg/m ³
Sensor	Oil mist and particle sensor

Pressure

Accuracy	0.5 % FS
Measuring range	0 ... 16 bar(g)
Resolution	0.01 bar
Sensor	Piezoresistive pressure sensor

Signal / Interface & Supply

Fieldbus

Protocol	Modbus/RTU (RS485) Modbus/TCP (Ethernet)
----------	---

Power supply

Voltage supply	100 ... 240 VAC, 50/60 Hz, 50 VA
----------------	----------------------------------

Interface

USB	USB Micro with OTG support
M12	4G/LTE Modem

General data

Configuration

Others	Device comes pre-configured Configuration can be done via on-screen touch
--------	---

Display

Integrated	5" color touch screen
------------	-----------------------

Data Logger

Storage	100 million measurement values
Report	Integrated report generator for PDF export

Material

Process connection	6 mm quick connector
Housing	Sheet steel, powder-coated on the outside (Stainless steel on request)

Miscellaneous

Electrical connection	M12, PG plug, RJ45
Protection class	IP54
Water Inlet	G1 connector
Water Outlet	G1/8 connector
Dimensions	600 x 600 x 250 mm
Weight	34 kg

Approvals

EMC	FCC, CE
-----	---------

Operating conditions

Measuring Medium	Compressed breathing air
Sample Flow Rate	6 LPM@4 MPa(g), depends on input pressure
Sample rate	1 sample/sec
Medium temperature	0 ... +45 °C
Medium humidity	Medium humidity < 40 % rH, no condensation
Inlet Pressure	0.4 ... 1.5 MPa(g), External pressure reducer allow up to 35 MPa process pressure
Ambient temperature	0 ... +50 °C
Ambient humidity	0 ... 90 % rH
Storage temperature	-10 ... +50 °C
Transport temperature	-10 ... +50 °C



Ordering

Please use the following tables to assist in placing your order with our sales staff.

S606 Stationary Breathing Air Quality Analyzer

Order No.	Description
KA66D5000606	S606 Stationary Breathing Air Quality Analyzer, touch screen interface, data logger, metal cabinet for wall mounting (with oil vapor sensor refer to Europe, USA, Canada standards)*
KA66D5001606	S606 Stationary Breathing Air Quality Analyzer, touch screen interface, data logger, metal cabinet for wall mounting (with oil mist and particle sensor refer to China standards)*
KA66000A1670	USB 4G dongle, including S4A software
KA66A5540131	4G USB Dongle protection case, with extension cable 2 m and M12 Connector
KA66000A1510	Relay module for S606, 8-ch Relay Output

* Including:

- USB OTG memory stick
- Purge filter for pre-measurement (test kit)
- Connection hose 1.5 m, one end quick coupling, one end compressed air coupling
- M12 connector
- Certificate of calibration
- Operation and instruction manual

Accessories

Order No.	Description
KA66A5540602	Purity test kit consisting of zero filters for oil vapor, particles, and a desiccant cartridge for low dew point creation
KA66A5541203	Oil vapor zero filter, 1.5 MPa max, with quick connectors at both ends
KA66A5541204	Particle zero filter, 1.5 MPa max, with quick connectors at both ends
KA66A5541205	Dew point test kit for low dew point generation, with quick connectors at both sides
KA66A6040004	Pressure reducer, inlet pressure 0-30 MPa, outlet pressure 0.6 Mpa
KA66A6040005	Pressure reducer, inlet pressure 0-40 MPa, outlet pressure 0.6 Mpa

Service and Calibration

Order No.	Description
KA66R2000605	S606 General service and re-calibration <ul style="list-style-type: none"> • General inspection of the unit • Replacement of tubes and fittings • Cleaning of components • Calibration O₂, CO₂, CO, dew point sensor and oil vapor • Assembly and test of unit • Calibration Certificate

Exchange sensors

KA66R2000620	CO exchange sensor unit S605/S606
KA66R2000621	CO ₂ exchange sensor unit S605/S606
KA66R2000622	O ₂ exchange sensor unit S605/S606
KA66R2000623	Oil mist and particle sensor exchange unit S605/S606
KA66R2000624	Oil vapor sensor exchange unit S605/S606
KA66R2000625	Dew Point sensor exchange unit S605/S606



www.kompauto.com



sales@kompauto.com



S530



Ultrasonic Leak Detector

Eco Version



EASY TO USE
Find leaks in minutes



LASER POINTER
To spot the leak



COMPACT DESIGN
Can be used anywhere



NOISE ISOLATED HEADSET
Inaudible signals easily to be heard



LONG BATTERY LIFE



Operation Principle

When gases are leaking through tubes and tanks, an ultrasonic sound is produced which can be detected by the S530 even from several meters away. The S530 transforms these inaudible signals into a frequency which can be easily heard by using the supplied noise isolated headset.

The integrated laser pointer helps to spot the leak from distance. In unpressurized systems, an ultrasonic tone generator can be used whose sound will leak through small openings.

Save Your Time and Costs

Leaks in compressed air systems can significantly increase the cost of compressed air.

The detection of leaks is an important maintenance requirement, which can be done by soapy water or in a more convenient way with ultrasonic leak detectors like S530.

The S530 Leak Detector is providing an easy-to-use and cost-efficient solution to detect leaks in compressed air and gas systems.

Applications

- Leak detection in compressed air, refrigerants, simply of any gas!
- Insulation test of doors and windows

Easy to use



Leak Detection



Point with the laser at an assumed leak. The display will show the level of the leak.



Detection at medium distance for locating the leakage area.



Scan with the focus tube and focus tip the roughly location till the exact location is found.

Technical Data

Measurement

Flow

Sensor	Ultrasonic leak detection sensor
Laser	640 ... 660 nm wavelength 0.4 ... 0.5 mW output power

Supply

Power supply	Internal NiMH rechargeable battery
Operating time	6h

Headset

Headset	Noise isolated head set
Headset connection	3.5 mm stereo phone jack

General data

Display

Integrated	3 colour black-mask LCD, 10 level
------------	-----------------------------------

Material

Housing	PC + ABS
---------	----------

Miscellaneous

Protection class	IP30
Approvals	CE
Weight	2.5 kg for the full set

Operating conditions

Medium	Compressed Air, refrigerants and any compressed gases
Ambient temperature	0 ... +40 °C
Ambient humidity	< 90 % rH
Storage temperature	-10 ... +50 °C
Transport temperature	-20 ... +50 °C



Cost Saving

Compressed air is one of the most expensive energy forms. In Germany alone, 60,000 pneumatic systems consume 14,000,000,000 kWh electricity every year. 15 % to 20 % of this could easily be saved (Peter Radgen, Fraunhofer Institute, Karlsruhe). A large portion of these costs are caused by leaks in compressed air systems, allowing the air to "escape" unused.

Calculation example at 0.6 MPa:

1 hole of 1mm diameter = 270 EUR/year

Option

Ultrasonic tone generator to be used in pressure less systems. The generator emits ultrasonic waves which can be detected by the S530.



Ordering

Please use the following tables to assist in placing your order with our sales staff.

S530 Ultrasonic Leak Detector

Order No.	Description
P601 0103	S530 Ultrasonic Leak Detector set <i>Including:</i>
P560 0102	S530 Ultrasonic Leak Detector
S605 0001	Sensor unit
A554 0114	Noise isolated headset Focus tube and focus tip
A554 0001	Battery charger
A554 0101	Transport case S530

Accessories

Order No.	Description
	Ultrasonic tone generator

Contents of Set

Head set



Charger



Focus tip



Focus tube



S530



www.kompauto.com



sales@kompauto.com



S531



Smart Ultrasonic Leak Detector

Professional Version

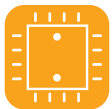

MASS STORAGE
Almost unlimited memory for leak records, photos and voice recording



DETECT FROM DISTANCE
Finds leaks in compressed air system easily even from distance



WIRELESS CONNECTION
Wireless connection to headset



ANALYSIS
Export data to LMS for statistics and repair



PHOTOGRAPH LEAK PARTS
Build in camera to take photo of leak locations



LOSS CALCULATE
Calculates air loss in m³/h or in local currency



VOICE RECORDING
Voice recorder for voice memos



NOISE REDUCTION
Integrated noise reduction



LASER
Pinpoint locations with laser pointer



LONG WORKING HOURS
Battery capacity for up to 6 hours



Benefits

- ✓ Finds leaks in compressed air system easily even from distance
- ✓ Full support for Leak Surveys with the SUTO Leak Management Software (LMS)
- ✓ The perfect tool for professional leak detection
- ✓ Fast return on investment
- ✓ Easy to use, but powerful in performance

Detect and manage your compressed air leaks — save your time and costs

Finding leaks in the compressed air system is the first step into energy saving. The leaking compressed air causes immense electrical costs, as your compressors are running more than they would actually need to run.

S531 is a smart ultrasonic leak detector that helps users quickly find and record leakages in compressed air or any gas systems. The built-in touch screen assists the user easy operation in leak detecting. Photographing and voice recording make leak surveys more flexible and efficient.

S531 is designed to work with SUTO Leak Management Software (LMS) to enable companies to properly manage their leakage detection and repair activities.

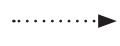

Leak Management Software (LMS)

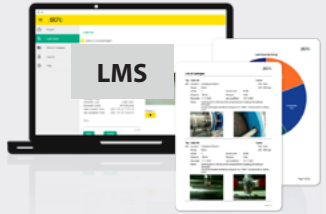

LMS included for free

When purchasing a S531 set, one free LMS license is included. Start immediately creating powerful leak reports, without paying extra for additional software licenses.

Leak Detection



Point with the laser at an assumed leak. The display will show the level of the leak.



Detection at medium distance for locating the leakage area. Record the leak losses at closer distance.



If needed, scan with the focus tube and focus tip till the exact location is found.



Seamless Connection with Leak Management Software (LMS)



Cost Saving

Compressed air is one of the most expensive energy forms. In Germany alone, 60,000 pneumatic systems consume 14,000,000,000 kWh electricity every year. 15 % to 20 % of this could easily be saved (Peter Radgen, Fraunhofer Institute, Karlsruhe). A large portion of these costs are caused by leaks in compressed air systems, allowing the air to "escape" unused.

Calculation example at 0.6 MPa:

1 hole of 1mm diameter = 270 EUR/year

Option

Ultrasonic tone generator to be used in pressure less systems. The generator emits ultrasonic waves which can be detected by the S530.



Technical Data

Measurement

Selectable units	l/min, m ³ /h, cfm, bar, MPa, psi
Sensor	Ultrasonic leak detection sensor
Laser	Wave length: 640 ... 660 nm Output power: < 1.0 mW
Camera	5.0 mega pixels

Interface & Supply

Supply

Power supply	Internal lithium-ion battery
Operating time	6 h

Data interface

Connection	USB port for charging and data exchange
------------	---

Headset

Headset	Noise isolated headset
Headset connection	Wireless and 3.5 mm stereo phone jack for headset

General data

Display

Integrated	3.5" color LCD touch screen
------------	-----------------------------

Data Logger

Storage	Integrated mass storage, 100 Million values
---------	--

Material

Housing	PC + ABS
---------	----------

Miscellaneous

Protection class	IP30
Approvals	CE
Weight	430 g for the leak detector 3.65 kg for the full set

Operating conditions

Medium	Compressed Air, refrigerants and any compressed gases
Ambient temperature	0 ... +40 °C
Ambient humidity	<90 % rH
Storage temperature	-10 ... +50 °C
Transport temperature	-20 ... +50 °C



Ordering

Please use the following tables to assist in placing your order with our sales staff.

S531 Smart Ultrasonic Leak Detector

Order No.	Description
KA66P6010104	S531 Smart Ultrasonic Leak Detector Set <i>Including:</i>
KA66P5600104	S531 Smart Ultrasonic Leak Detector
KA66A5540119	Noise isolate/canceling headset, wireless
KA66A5300101	Focus tube and focus tip for accurately pinpointing
KA66A5540123	Trumpet for locating leaks over longer distances
KA66A5540117	Battery charger
KA66A5540118	Transport case S531
KA66A5540122	Leak tags to mark found leaks, 100 pieces

Accessories

Order No.	Description
KA66A5540103	Ultrasonic tone generator
KA66R2000070	Calibration S531

Scope of delivery

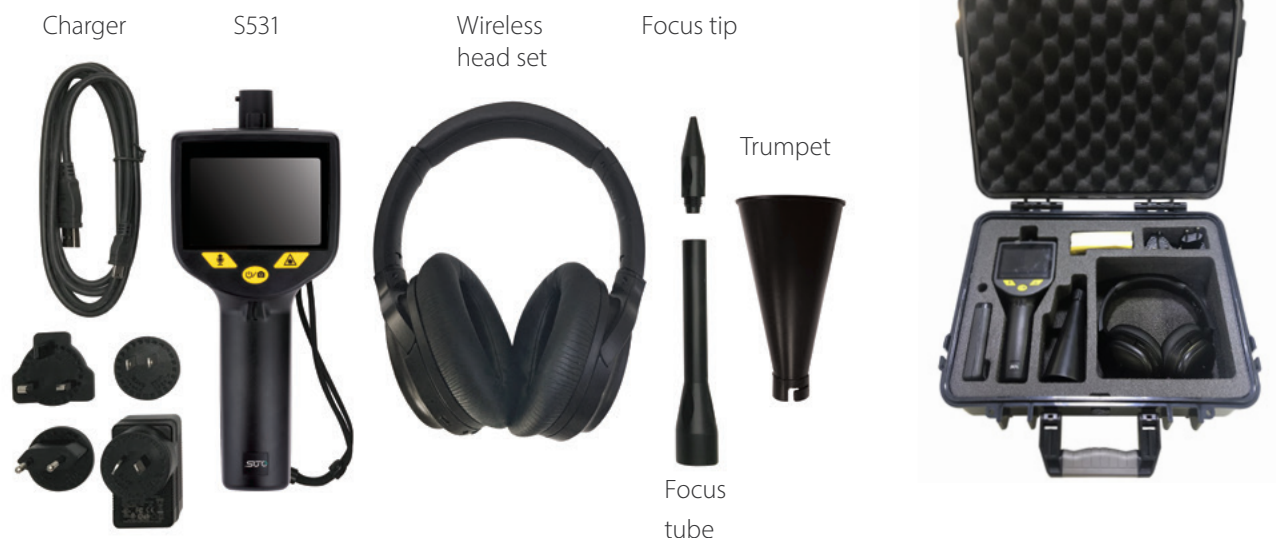

www.kompauto.com



sales@kompauto.com



Leak Management Software

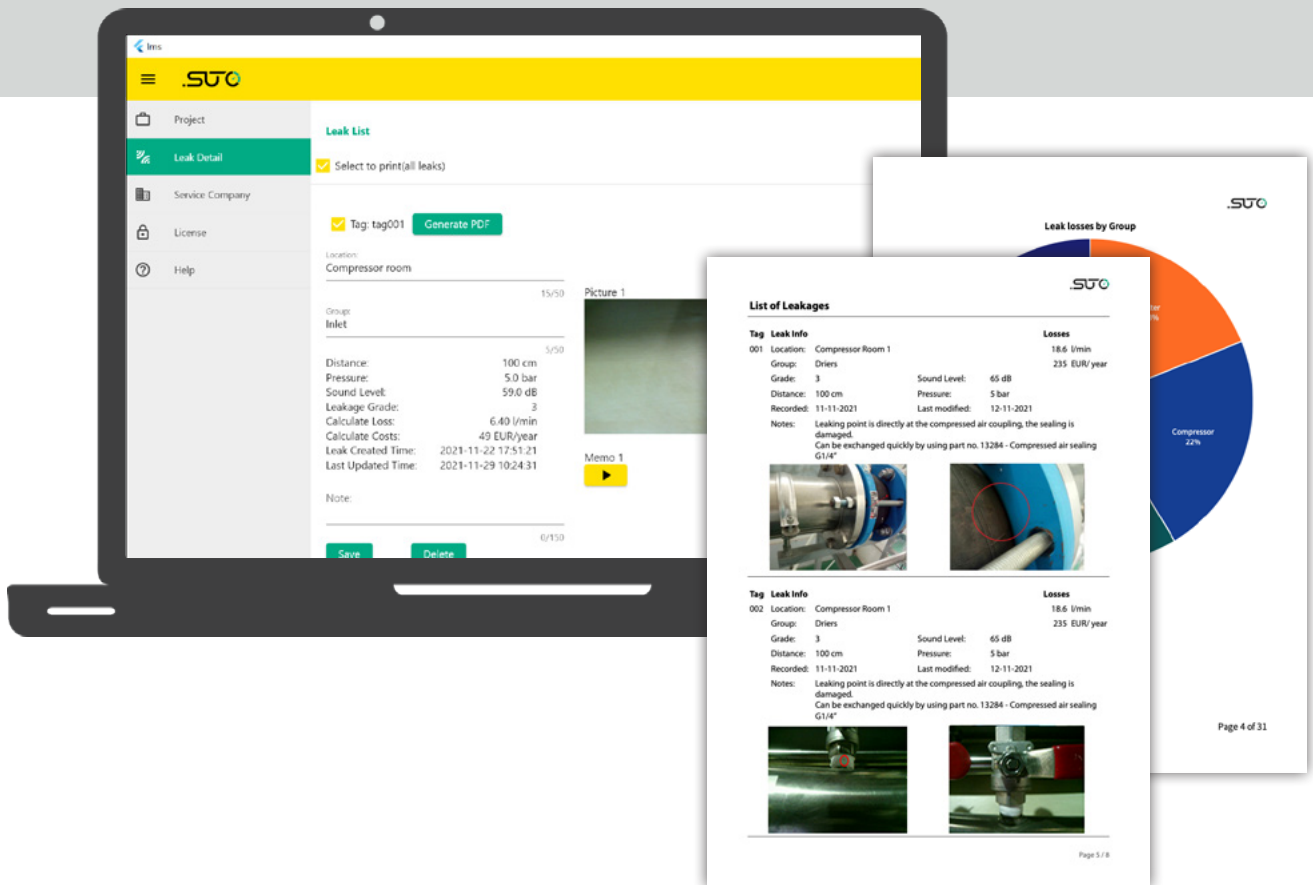

Manage your compressed air leaks — **save your time and costs**

The Leak Management Software (LMS) provides a total solution for leak detection, management and easy report creation. The software comes as a local installation on a PC and works seamlessly with our S531 ultrasonic leak detector. Recording leaks in the field using SUTO S531 leak detector and later importing them to LMS software enables users to gather quantitative leak loss data and easily create powerful reports which provide a full overview of the customers' leak situation.



Benefits

- ✔ Simple and user-friendly user interface for easy navigation and leak survey handling
- ✔ Reports can be personalized with your own company logo and contact information
- ✔ Save your valuable time in report documentation by having a one-click report
- ✔ Adjust your reports to local specifications by using the integrated unit converter

Convenient User Experience



FLAT INTERACTION DESIGN
Simplify the operation steps



LOCAL INSTALLATION
Easy to install and save your data locally



ONE-CLICK IMPORT AND UPDATE
Import and update new leak data just by a simply click

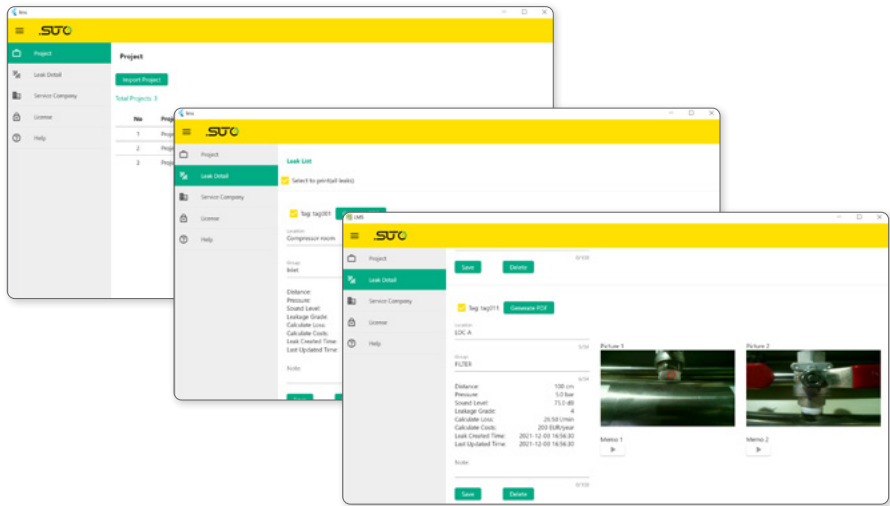

Powerful Analysis Reports



EXTENSIVE ANALYSIS REPORT
Leak report with all relevant data



PERSONALIZED CONFIGURATION
Upload your company logo, contact person etc.



PRINT CONTENT OPTIONAL
Select your desired leaks to be printed

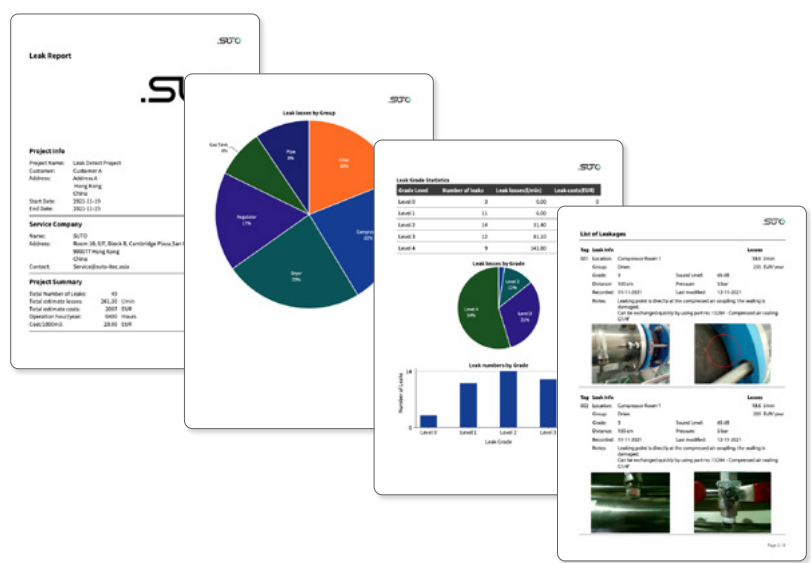



Seamless Connection with S531



Included in S531 for free

When purchasing a S531 ultrasonic leak detector set, one free LMS license is included. Start immediately creating powerful leak reports, without paying extra for additional software licenses.

Ordering

Leak Management Software (LMS)

Order No.	Description
KA66M5997045	Leak Management Software (LMS), Local installation, 1 license (bound to local PC)*, one-time payment

* The software license is bound to the local PC, still the same software can be used by multiple users on the same PC.

Trial Period

Test it for 30 Days!

If you want to try LMS we are offering a 30 days trial period with full functionality.

When the 30 days are due to expire, in order to continue using the software you need to buy a license.



www.kompauto.com



sales@kompauto.com



S110



Power and Energy Meter



S110



S110-P



MULTIFUNCTION POWER AND ENERGY METER
3-phase, 1-phase



COMPRESSOR PERFORMANCE
Helps to identify compressor efficiency

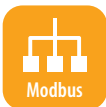

MODBUS/RTU INTERFACE
Connects to any Modbus-Master



ROGOWSKI COILS
Wide range, highly accurate



Benefits

- ✓ Convenient and easy to set up compressor performance and efficiency monitoring
- ✓ Real power consumption in kW and kWh by measuring each phase voltage and current
- ✓ DIN rail installation for power cabinets or portable version with rugged housing
- ✓ Power range up to 2 MW (2000 kW)
- ✓ Three current sensor models with 100 A, 1000 A or 3000 A available

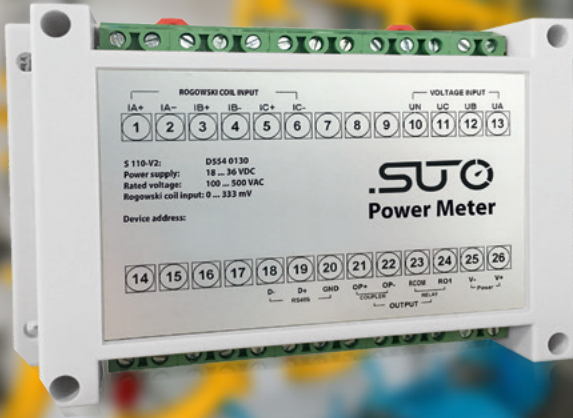

Operation Principle

The SUTO Power and Energy Meter has been designed with a focus on easy installation and reliable measurements. The main application is to measure the power consumption and the accumulated energy consumption of electrical 3-phase consumers, like compressors, driers and oxygen/nitrogen generators.

The main difference to common power measurements is that all relevant parameters are real measured values and not assumptions. Unlike the traditional method, where only one phase is measured, the voltage is assumed as stable and the phase shift is entered as a constant, the S110 measures the voltage and current of each phase.

By this, the S110 is much more accurate and delivers more reliable measurements compared to single phase current measurements.

Application

In this illustration, a Power and Energy Meter is installed directly into the connection box of the compressor.

The Rogowski current coils are easy to install, by just clamping them around the power cables. The voltage connection can be drawn directly from the power cabinet of the compressor.

The Power and Energy Meter is then connected to a S330 / S331 Display and Data Logger to record the Voltage and Current of each phase, as well as recording the actual power consumption and the total energy consumption.

This is not only used to identify inefficient compressors, but also letting the compressed air operator know what the real costs of the compressed air are.

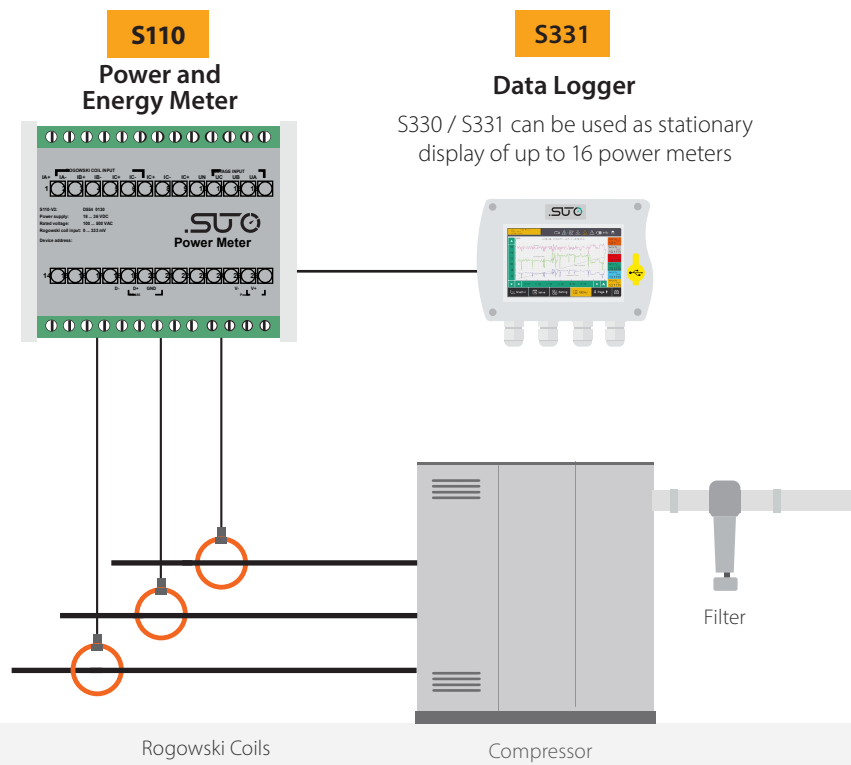

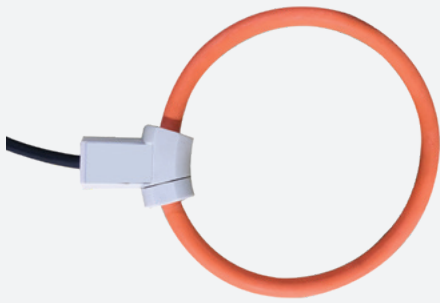

Current Measuring via Rogowski coils offers a high accuracy over a wide range and an easy installation. (Note: for each phase, one coil is needed)

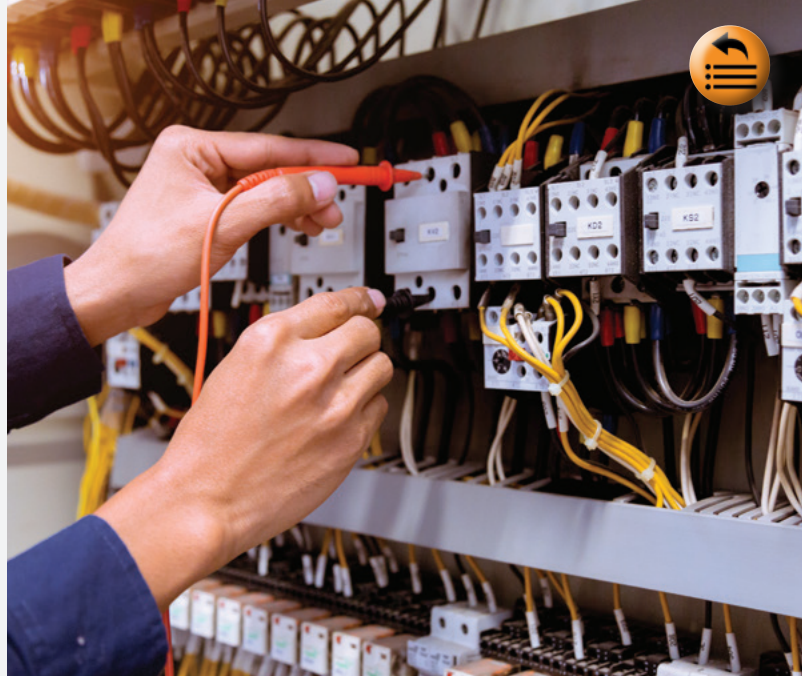

S110-P

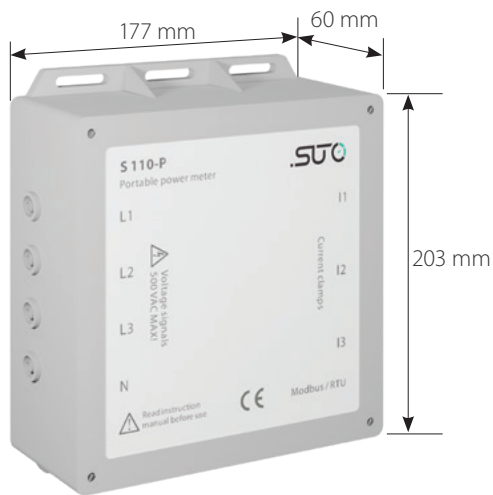

Monitoring Software



Wireless Connection

S551

Portable Data Logger
Can be used as onsite portable display

Compressor Efficiency Test

Knowing your compressor efficiency is the first step for your energy saving goals. With this solution you will know, how much electrical energy is needed to produce 1 m³ compressed air and what are the electrical costs.

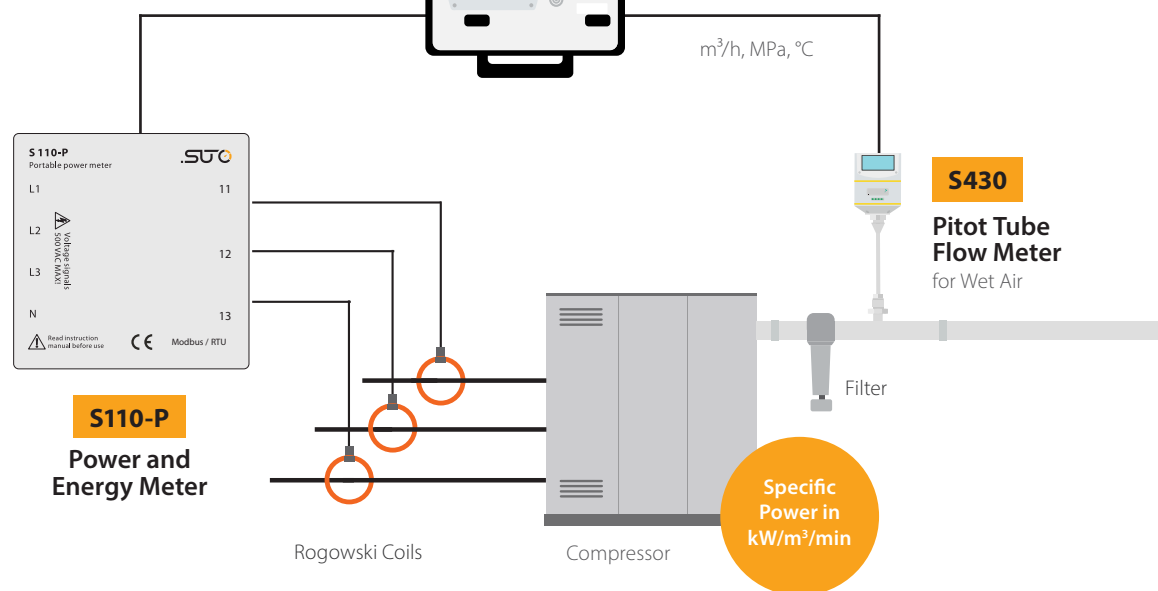



Technical Data

Measurement

Flow

Accuracy	V = 0.2 %, A = 0.5%
Selectable units	V, A, kW, kvar, kVA, kWh, Hz
Measuring range	100 ... 500 VAC, up to 2500 kW
Sampling rate	8 k/s

Signal / Interface & Supply

Fieldbus

Protocol	Modbus RTU
----------	------------

Supply

Voltage supply	24 VDC S110 1 W
	24 VDC S110-P 2 W
Current consumption	Max. 50 mA

Data interface

Connection	M12 connector
------------	---------------

General data

Material

Housing	ABS
---------	-----

Miscellaneous

Protection class	IP20
Approvals	CE
Weight	0.21 kg

Operating conditions

Ambient temperature	-25 ... +55 °C
Storage temperature	-40 ... +85 °C

Ordering

Please use the following tables to assist in placing your order with our sales staff.

S110 Power and Energy Meter

Order No. Description

Stationary

KA66D5540130	S110 Power and Energy Meter, hat rail, Modbus/RTU, 24 VDC supply
KA66S5540140	Electrical Current Transmitter for S110, 1000 A, 100 mm diameter, 1.8 m cable, open ends
KA66S5540141	Electrical Current Transmitter for S110, 3000 A, 150 mm diameter, 1.8 m cable, open ends
KA66S5540142	Electrical Current Transmitter for S110, 100 A, 16 mm diameter, 1.8 m cable, open ends

Portable

KA66P5540134	S110-P Portable Power and Energy Meter, incl. 5 m connection cable to S551 (Modbus/RTU), 4 voltage test leads and 4 test clips
KA66S5540160	Electrical Current Transmitter for S110-P, 1000 A, 100 mm diameter, 1.8 m cable, connector to S110-P
KA66S5540161	Electrical Current Transmitter for S110-P, 3000 A, 150 mm diameter, 1.8 m cable, connector to S110-P
KA66S5540162	Electrical Current Transmitter for S110-P, 100 A, 16 mm diameter, 1.8 m cable, connector to S110-P



www.kompauto.com



sales@kompauto.com



S694



Pressure Transmitter

Seamless Integration into your Compressed Air System

Pressure is the key point in a compressed air system. This makes it crucial to keep the pressure at a constant and reliable level. Monitoring and measuring the compressed air pressure is needed to save energy, identify degrading at an early stage and keep production machinery running.

SUTO pressure transmitters are made to seamlessly integrate into your compressed air monitoring system and provide reliable measurement results.

Available in Three Ranges

- 0... 1.6 MPa(g)
- 0... 4.0 MPa(g)
- 0... 0.16 MPa(abs.)

Signal Output

The pressure transmitter is offered as a 2-wire analog output version for easy connection.

For modern monitoring solutions, the Modbus/RTU version allows to easily connect multiple transmitters to a single data logger.



Benefits

- ✓ High accurate and affordable industrial pressure transmitter
- ✓ Excellent anti-interference capability (EMC, EMI)
- ✓ Salt-spray, temperature and humidity tested
- ✓ IP67 protection
- ✓ 4 ... 20 mA 2-wire loop powered or Modbus/RTU output

Industrial equipment for manifold applications

- Hydraulic systems
- Pneumatic systems
- Industrial engines
- HVAC/R equipment
- Spraying systems
- Cooling systems

Technical Data

Measurement

Pressure

Accuracy	±0.5 % F.S (optional ±0.25 % F.S)
Measuring range	0 ... 4.0 MPa
Response time (t90)	≤1 ms (@ 90 % F.S)

Signal / Interface & Supply

Analog output (for 4 ... 20 mA type)

Signal	4 ... 20 mA, (2-wire loop powered)
Load	Max. 250 Ohm

Fieldbus (for Modbus/RTU type)

Protocol	Modbus/RTU
BUS-Length	≤ 1000 m

Supply

Voltage supply	11 ... 36VDC
Current consumption	Max. 20 mA

Data interface

Connection	M12 Connector
------------	---------------

General data

Material

Process connection	Stainless steel 1.4301
Housing	Stainless steel 1.4301
Metal parts	Stainless steel 1.4301

Miscellaneous

Electrical connection	M12 Connector
Protection class	IP65
Approvals	CE
Process connection	G1/4" (ISO 228/1)

Operating conditions

Medium temperature	-40 ... +85 °C
Ambient temperature	-40 ... +85 °C
Storage temperature	-40 ... +125 °C

Dimensions (4 ... 20 mA Type)

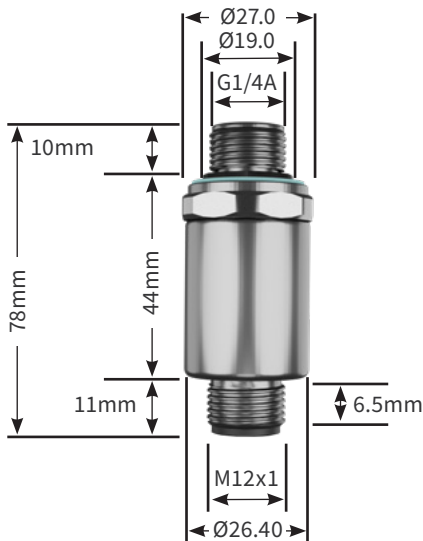

Dimensions (Modbus/RTU Type)

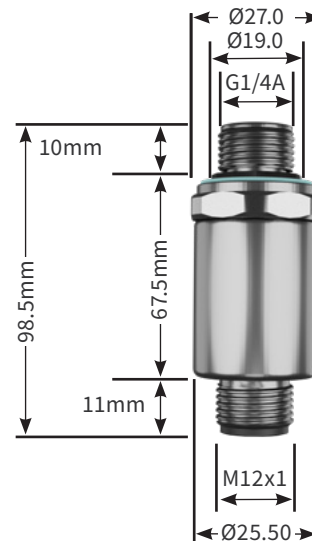



Ordering

Please use the following table to assist in placing your order with our sales staff.

Pressure Transmitter

Order No.	Description
KA66S6943557	Pressure Transmitter, 0 ... 1.6 MPa(g), 2-wire 4 ... 20 mA output, incl. M12 connector, G1/4" thread
KA66S6942559	Pressure Transmitter, 0 ... 1.6 MPa(g), Modbus/RTU, incl. M12 connector, G1/4" thread
KA66S6943558	Pressure Transmitter, 0 ... 4.0 MPa(g), 2-wire 4 ... 20 mA output, incl. M12 connector, G1/4" thread
KA66S6942562	Pressure Transmitter, 0 ... 4.0 MPa(g), Modbus/RTU, incl. M12 connector, G1/4" thread
KA66S6942564	Pressure Transmitter, 0 ... 0.16 MPa(a), 2-wire 4 ... 20 mA, incl. M12 connector, G1/4" thread
KA66S6942563	Pressure Transmitter, 0 ... 0.16 MPa(a), Modbus/RTU, incl. M12 connector, G1/4" thread
KA66A5530104	Sensor cable 5 m, with M12 connector, open wires, AWG 24 (0.2 mm ²)
KA66A5530105	Sensor cable 10 m, with M12 connector, open wires, AWG 24 (0.2 mm ²)
KA66R2000030	Pressure Transmitter calibration at 3 points



www.kompauto.com



sales@kompauto.com



S554



.SUTC
**Electrical Current
Transmitter**





Benefits

- ✓ Easy installation
- ✓ Wide measuring range
- ✓ Accurate current sensing
- ✓ 4 ... 20 mA output signal
- ✓ IP67 casing provides robust protection in the industrial environment

Accurate current measurement

SUTO current sensor is an AC RMS current sensor composed of a flexible active part (Rogowski coil model) connected to a compact digital converter, capable of measuring the current carried on a power conductor up to a value of 3000 A AC.

The digital converter supplies an output of 4 ... 20 mA DC in linear proportion to the measured current.

Current Transmitter Application

- Current sensing at compressors for load / unload analysis
- Current sensing for power / energy measurement
- Evaluation of machine operation hours

Position Sensitivity

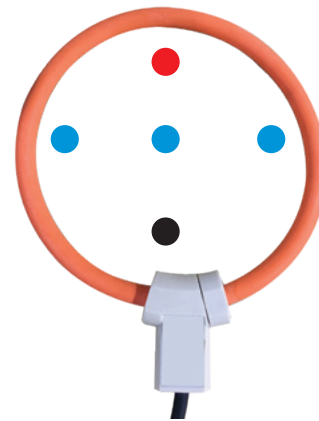

Conductor Position	Typical Error(%)
	<0.5%
	<0.8%
	<1%

Single Phase Power Measurements

By measuring the current of a symmetric power consumer on one phase, compressed air experts are able to calculate the power consumption of the compressors without the need of measuring voltage additionally.

This offers an analysis of the compressor and allows to judge the efficiency of the system.

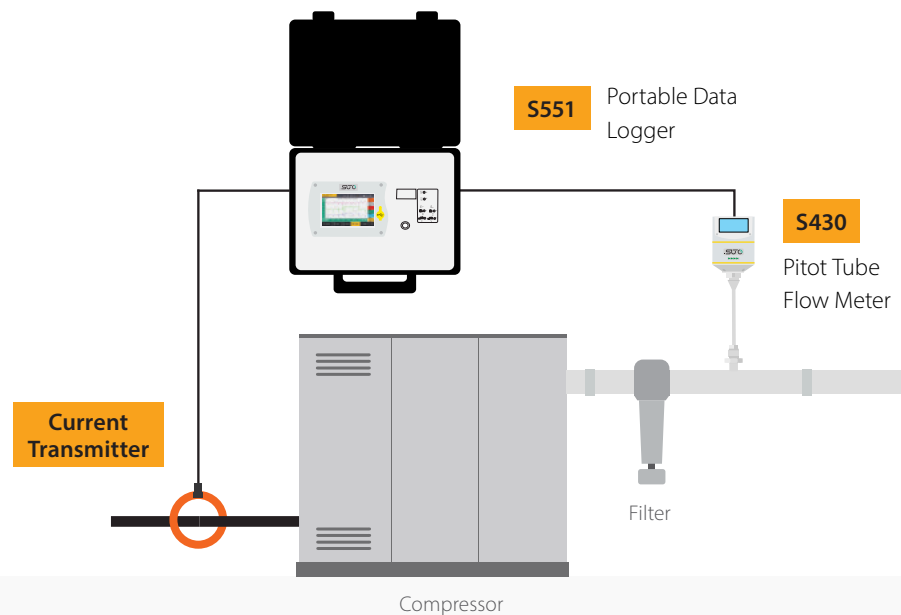

Technical Data

Measurement

Current

Accuracy 0,5 % of reading + 0,2 % of range

Signal / Interface & Supply

Analog output

Signal 4 ... 20 mA 3-wire
 Scaling 4 mA = 0A AC,
 20 mA = 1000A / 3000 A AC

Load Max. 300 Ohm

Supply

Voltage supply 10 – 32 VDC
 Current consumption Max. 30 mA

Data interface

Connection open wire ends / ODU connector

General data

Miscellaneous

Protection class IP67

Approvals CE

Operating conditions

Ambient temperature 0 ... +80 °C

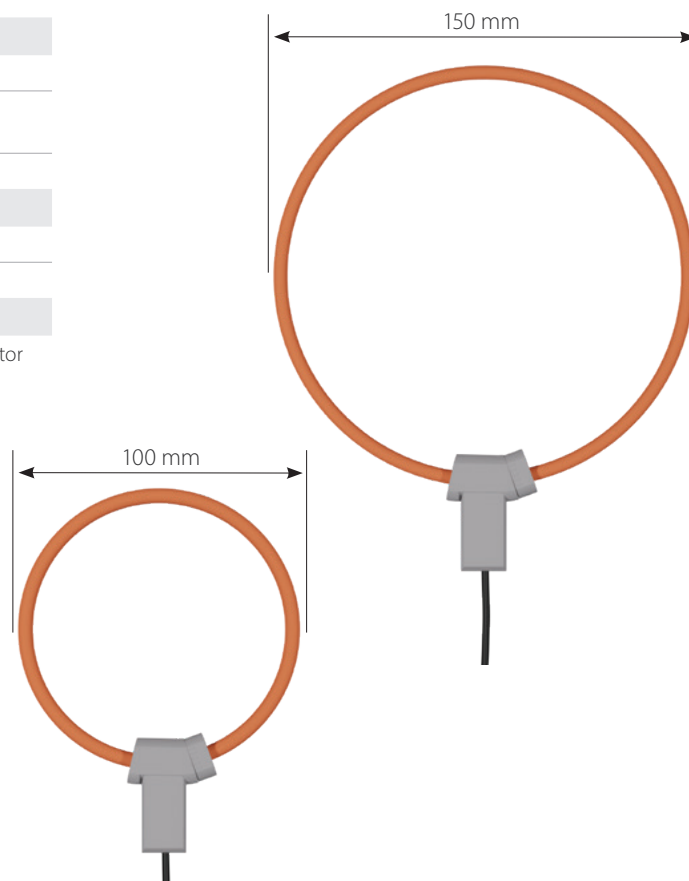

Ordering

Please use the following table to assist in placing your order with our sales staff.

Electrical Current Transmitter

Order No.	Description
KA66S5540155	Electrical Current Transmitter, 1000 A, 100 mm diameter, open wire ends
KA66S5540156	Electrical Current Transmitter, 1000 A, 100 mm diameter, including connector to S551
KA66S5540157	Electrical Current Transmitter, 3000 A, 150 mm diameter, including connector to S551
KA66S5540158	Electrical Current Transmitter, 3000 A, 150 mm diameter, open wire ends



www.kompauto.com



sales@kompauto.com



Calibration and Certification

Calibration certificate 

Instrument: S401
Serial number: 1234 5768
Item number: 5698 8371



Test conditions:

Test medium:	Air	Ambient temperature:	18...26°C
Test temperature:	23°C	Ambient humidity:	30...60% rH
Test humidity:	<30 %rH	Ambient pressure:	990...1050 mbar
Test pressure:	6 bar	Calibration range:	High speed
Testing tube D:	53.1 mm	Testing method:	Calibration by comparison

References used:

Type	Model	Uncertainty	S/N	Last Calibration
Turbine Flow Meter	FT-32	± 0.50%	141119E39096	10.2021
Laminar Flow Element	LFE0	± 0.50%	1836000032	10.2021
Sonic Nozzels	N0-N4	± 0.50%	831K033-37	10.2021

Calibration test results:

Description	Units	Nominal value	Permissible uncertainty	Actual value	Evaluation
Flow	m ³ /h	142.2	±(1.5 % + 0.3% FS)	143.1	passed
Flow	m ³ /h	285.4	±(1.5 % + 0.3% FS)	286.1	passed
Flow	m ³ /h	611.2	±(1.5 % + 0.3% FS)	611.2	passed

The above-mentioned calibration was performed according to SUTO ITEC working standards. Furthermore the calibration was performed by comparison with instruments, which have been calibrated at an ISO 17025 accredited calibration laboratory and is traceable to national standards. It represents the physical units according to the International System of units (SI). The reference measurement system used for this calibration has a total uncertainty of 0.65% (at confidence level: 95%)

We commend that this measuring instrument should be calibrated annually.

The product has been calibrated by:

SUTO ITEC GmbH
 Gütthelm Weg 21
 79423 Heitersheim
 Tel: ++49 (0) 7634 50488-00
 Fax: ++49 (0) 7634 50488-19
 E-mail: sales@suto-itec.com
 Web: www.suto-itec.com

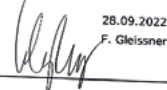
Calibration date: 28.09.2022
SUTO Inspector: F. Gleissner
Signature: 



Page 1 of 2

5006 1 01 3

www.suto-itec.com
 Tel: ++49 (0) 7634 50488-00
 Fax: ++49 (0) 7634 50488-19
 E-mail: sales@suto-itec.com
 Web: www.suto-itec.com

Signature: 



FLOW CALIBRATION



PARTICLE CALIBRATION



OIL VAPOR CALIBRATION



EXCHANGE CALIBRATION



DEW POINT CALIBRATION



PRESSURE CALIBRATION



TEMPERATURE CALIBRATION



Benefits

- ✓ SUTO owned high tech calibration facilities for Dew Point, Compressed Air Flow, Oil vapor, Pressure, Temperature in Germany, Hong Kong and China
- ✓ Flow calibration under pressure and a wide range for highest accuracy
- ✓ Real gas calibration system for technical gases
- ✓ SUTO Exchange Calibration Service to minimize downtimes
- ✓ References and certificates are traceable to national standards

Flow Calibration Service

- Accuracy: < 0.5% o. RDG
- Range: 0... 260 m/s (20°C 1000 mbar)
- Pressure: 0... 0.7 MPa
- Pipe sizes: DN8... DN100
- Medium: Compressed Air and technical Gasses
- References: Sonic Nozzles, Laminar Flow Elements, Turbine Meter, Coriolis Meter



Dew Point Calibration Service

- Accuracy Frost/Dew point: $\leq \pm 0.1$ °C
- Accuracy Temperature: $\leq \pm 0.07$ °C
- Calibration Range: -85... +15 °C Td
- Reference: MBW 373 Dew Point Hygrometer / Dew Point Mirror



Oli Vapor Calibration Service

- Accuracy: $\leq \pm 3$ % o. RDG
- Gas: Isobutylene in synthetic air
- Reference: Traceable and certified gas
- Range: 0.000... 10.000 mg/m³
- Multiple activated carbon filtration system for accurate zero-point calibration





SUTO | Exchange Service

Exchange Service

No Downtime anymore!

The exchange calibration service eliminates down time and enables users to have a seamless record of their dew point measurements.

The user receives in advance a calibrated instrument with calibration certificate and the same instrument settings. The onsite instrument is then switched against the calibrated one and returned to the supplier.

Ordering

Please use the following table to assist in placing your order with our sales staff.

Calibration and Certification

Order No.	Description	
KA66R2000001	Flow calibration with certificate	
KA66R2000005	Oil- & grease-free cleaning option for flow sensors (For Oxygen, it is already included in KA66000A1009.)	
KA66R2000020	Re-calibration, real gas: O ₂ , Ar, CO ₂ , H ₂ (H ₂ real gas calibration needs to consult with manufacturer in advance)	
KA66R2000021	Re-calibration, real gas: CH ₄ , NG, N ₂ O (please consult with manufacturer in advance)	
KA66R2000022	Real gas calibration for He	
KA66R2000030	Pressure sensor calibration 16bar(g) type, at 3 points	
KA66R2000040	Re-calibration ultrasonic flow meter S460	
KA66R2000050	Dew point calibration, one additional point, freely selectable in the range -75 ... +20 °C Td	
KA66R2000070	Calibration for S531	
KA66R2000080	Re-calibration per unit for S110 power meters or Rogowski coils	
KA66R2000120	General service and re-calibration:	
	- General inspection of the unit - Replacement of tubes and fittings - Cleaning of lamp and sensor	- Assembly and test of unit - Calibration of oil sensor S120
KA66R2000130	Calibration for particle counter S130	
KA66R2000131	Calibration for particle counter S132	
KA66R2000600	S600 Service and calibration:	
	- General inspection of the unit - Replacement of tubes and fittings - Cleaning of components	- Calibration oil vapor, particle and dew point sensor - Assembly and test of unit - Calibration
KA66R2000610	Isokinetic sampler service / flow calibration	
KA66R6993396	Dew point sensor calibration	
KA66R2004610	Calibration for S461 ultra sonic transducer pair	
KA66R2004613	Calibration for S461 temperature sensor	
KA66R2004620	Calibration for S462	



www.kompauto.com



sales@kompauto.com



ACC



.STC

Accessories

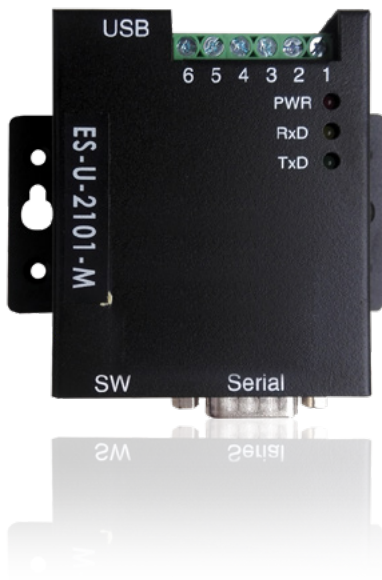

Ordering

Please use the following table to assist in placing your order with our sales staff.

Order No.	Description	Application	Picture
KA66C1900002	Closing cap for S421/S452 material: 1.4404	To close the measuring sections in case the sensor unit is removed	
KA66C1900060	Thread adaptor, G 1/2" internal to PT 1/2" external, SUS303	Used to adapt S401 or S450 to a PT thread ball valve	
KA66C1900065	Thread adaptor, G 1/2" internal to NPT 1/2" external, SUS303	Used to adapt S401 or S450 to a NPT thread ball valve	
KA66C1900116	Flow conditioner	Wafer type flow conditioners, which is flanged between two flanges 5-8 times diameter upstream of the flow meter. Please specify nominal pipe diameter and pressure	
KA66A5301105 / KA66A5301106 / KA66A5301111 / KA66A5301113	High pressure installation device. To be used for pressure > 1.5 MPa	For safety reasons we recommend using this installation device whenever the operating pressure exceeds 1.5 MPa * KA66A5301105 - High pressure installation device for S400/S401-220 mm * KA66A5301106 - High pressure installation device for S450-220 mm * KA66A5301111 - High pressure installation device for S400/S401-400 mm * KA66A5301113 - High pressure installation device for S450-400 mm	
KA66A5301108	SUTO spot drilling device G 1/2" for S401, S450 and S409	This drilling tool is used to drill holes into compressed air pipes under pressure through a ball valve	
KA66A5301205	HT20 G 3/4" hot tapping tool, for S430	Drill 3/4" holes into compressed air pipes under pressure through ball valves	
KA66A5530104	Sensor cable 5 m with M12 connector, open wires, AWG 24 (0.2 mm ²)	Used to connect SUTO sensors to a PLC or power supply	
KA66A5530105	Sensor cable 10 m with M12 connector, open wires, AWG 24 (0.2 mm ²)	Used to connect SUTO sensors to a PLC or power supply	
KA66A5530146	Sensor cable 5 m with M12 and RJ45 connectors, PoE supported, AWG 24 (0.2 mm ²)	Used to connect SUTO flow sensors to the Ethernet network via router, switch and etc.	
KA66A5530161	M8 female to M12 male converter cable	Used to connect the S415/S418 to a Modbus splitter	











Ordering

Please use the following table to assist in placing your order with our sales staff.

Order No.	Description	Application	Picture
KA66A5530165	Sensor cable, 5 pole, AWG 24 (0.2 mm ²), 50 m	Used to connect power supply and analogue signals to sensors	
KA66A5530166	Sensor cable, 5 pole, AWG 24 (0.2 mm ²), 100 m	Used to connect power supply and analogue signals to sensors	
KA66A5530167	RS-485 cable, 4 pole twisted pairs, AWG 24 (0.2 mm ²), 50 m	Used to connect power supply and RS-485 signal to sensors	
KA66A5530168	RS-485 cable, 4 pole twisted pairs, AWG 24 (0.2 mm ²), 100 m	Used to connect power supply and RS-485 signal to sensors	
KA66A5540009	Power supply for hat rail, input: 85 ... 264 VAC, output: 24 VDC, 60 W	This power supply can be used to supply sensors with 24 VDC/2.5 A It's mounted on a hat rail	
KA66A5540007	Power supply wall mountable, input: 85 ... 264 VAC, output: 24 VDC, 15 W, without cable	This power supply is used to supply 24 VDC to sensors and other devices	
KA66A5540008	½" G type ball valve	This is a proper ball valve for the installations of flow sensors S401/S450	
KA66P5540009	Wall thickness meter	The instrument is used to measure the wall thickness of pipes. Too often the inner diameter of pipes is not exactly known, but this information is required for an accurate flow measurement. By measuring the wall thickness and the pipe size the exact inner diameter can be calculated	
KA66A5540107	Mains unit 100-240 VAC/24 VDC, 0.5 A for S401 / S201 series, 2 m cable	Simple power supply for a portable S421 or S401 solution (Special plug on request)	
KA66A5542005	Service kit for sensor configuration including software	This service kit can be used for all SUTO sensors to change settings and check sensors	

Ordering

Please use the following table to assist in placing your order with our sales staff.

Order No.	Description	Application	Picture
KA66A6993491	Measuring chamber, 2 l/min @ 0.8 MPa, fast connector, without filter, max pressure 1.6 MPa, suitable for all SUTO dew point sensors	For easy connection and disconnection to compressed air system through quick-disconnector	
KA66A6993492	Measuring chamber, 2 l/min @ 0.8 MPa, 6 mm hose quick connector, without filter, max. pressure 1.6 MPa, suitable for all SUTO dew point sensors	For easy connection and disconnection to compressed air system through quick-disconnector	
KA66A6993493	By-pass-type chamber with 6 mm hose in and out connection up to 1.6 MPa	This chamber can be used in applications where the measured gas is by-passed through the chamber	
KA66A6993500	Measuring chamber, 4 l/min @ 0.8 MPa, hose fast connector, with filter, recommended pressure range 0.3 ... 1.5 MPa, convenient dew point measurement of gas/air with SUTO portable dew point meters	The sample gas/air is connected to the chamber through a 6 mm Teflon® hose The chamber is mounted to the SUTO portable dew point meters through the 1/2" G-type thread connection. Parking and measurement position is selected through the handle at the chamber, which allows quick measurement results	
KA66A6993501	By-pass-type chamber with 6 mm hose in and out connection up to 1 MPa, convenient dew point measurement of gas/air with SUTO portable dew point meters	This chamber can be used in applications where the measured gas is by-passed through the chamber to avoid any gas/air loss. The chamber is mounted to the SUTO portable dew point meters through the 1/2" G-type thread connection. Parking and measurement position is selected through the handle at the chamber, which allows quick measurement results	
KA66A6993496	Measuring chamber for dryer installation, 2 l/min @ 0.8 MPa, hose fast connector, without filter, max. pressure 1.6 MPa	The sample gas/air is connected to the chamber through a 6 mm Teflon® hose The chamber is mounted to stationary S2XX dew point sensors through the 1/2" G-type thread connection. This chamber can be conveniently mounted to the frame or cabinet of a dryer	
KA66A6993590	High pressure chamber up to 35 MPa	In applications where the pressure is exceeding 1.5 MPa, this chamber can be used. Through the adjustable valve a small purge is set to ensure a gas flow through the sensor element (response time)	
KA66A5540054	Compressed air quick coupling, female side R 1/2" thread	Connect this quick coupling to a 1/2" ball valve to set up a quick connector for measurement of dew point, oil and particle	
Dew point sensor protection caps		Protection caps are used to protect the dew point sensor element from mechanical impacts or dust. The proper cap selection depends in application Please contact customer service	



Ordering

Please use the following table to assist in placing your order with our sales staff.

Order No.	Description	Application	Picture
KA66A5540002	Test pot 11.3 % rH	Is used to check dew point sensors. The pot creates a constant relative humidity of 11.3 %. The resulting dew point is depending on the ambient temperature, at 25 °C it is equal to -6.3 °C	
KA66D5000005	S51 panel meter, with 4 ... 20 mA input and 2 alarm outputs, 85 ... 265 VAC supply, 96 x 48 mm panel	Installations in dryers or similar equipment as dew point indicator	
KA66C2190055	M12 connector with RS-485 termination resistor, 120 Ω	Termination resistor for enhancing communication stability of RS-485 network Connect it to the final device of RS-485 network	
KA66A5543310	M12 RS-485 (Modbus) splitter	Stationary Modbus splitter for easier wiring	
KA66A5540011	RS-485 Repeater	A repeater is used whenever the bus length of RS-485 exceeds 500 m. After every 500 m of cable distance a repeater is recommended	
KA66A5540331	RS-485 / USB converter	This converter brings RS-485 to the USB port of the PC.	
KA66D5540031	8-channel current input module, 0 ... 20 mA, Modbus/RTU	For connecting up to 8 sensors with 0 ... 20 mA / 4 ... 20 mA signal via RS-485 to S330 / S331.	
KA66A5540087	USB OTG memory stick	USB memory drive for transferring data between SUTO data loggers (S331 / S551 / S120 with display / S130 with display) and a PC. The USB drive has a USB-A and a Micro-USB connector	



www.kompauto.com



sales@kompauto.com



SG B127 / SG W127



AdsoMax Silica Gel

Desiccant for Compressed Air Adsorption Dryers

Silica Gel B127 and W127 are commonly used desiccants in compressed air dryers to effectively remove moisture from the compressed air stream. These desiccants are specifically designed to have high moisture adsorption capacities and are capable of maintaining low levels of humidity in the compressed air.

Silica Gel B127 and W127 are types of granular desiccants composed of silicon dioxide (SiO_2). They possess a highly porous structure with a large surface area, enabling them to attract and retain moisture molecules.

In compressed air dryers, the desiccant beds containing Silica Gel B127 or W127 are placed in a drying chamber. The compressed air is directed into the drying chamber, where it comes into contact with the desiccant material. As the air passes through the desiccant bed, moisture molecules are adsorbed onto the surface of the silica gel particles, effectively reducing the humidity level of the compressed air.

Silica Gel B127 and W127 are widely used in various industries, including manufacturing, pharmaceuticals, food and beverage, electronics, and automotive, where the presence of dry air is crucial for maintaining product quality, equipment performance, and overall process efficiency in compressed air systems.

AdsoMax desiccants are delivered in packing sizes depending on customer needs. From 1 kg packing up to BigBag packing with a weight of several hundreds of kilograms each.





AdsoMax Activated Alumina

Desiccant for Compressed Air Adsorption Dryers

Activated alumina is a highly effective and versatile desiccant widely employed in air and gas drying applications. Composed of porous aluminum oxide spheres, it exhibits remarkable moisture-absorbing properties, making it an indispensable component in drying systems.

When air or gas passes through a bed of activated alumina, its intricate network of interconnected pores captures and adsorbs water vapor, effectively reducing humidity levels. This process prevents corrosion, degradation, and clogging caused by excess moisture, thereby enhancing the longevity and performance of equipment and pipelines.



Activated alumina's exceptional thermal stability and low dust generation make it a preferred choice for various industries, including petrochemical, pharmaceutical, and food processing. Its large surface area allows for efficient moisture removal even at low temperatures, ensuring optimal operational conditions.

Routine reactivation is crucial to restore the desiccant's moisture-absorption capacity. This involves subjecting the spent activated alumina to elevated temperatures, which expel the accumulated moisture and rejuvenate its adsorption capabilities.

Activated alumina stands as a reliable and efficient solution for air and gas drying needs, safeguarding equipment, and processes against the detrimental effects of humidity, while contributing to the overall efficiency and reliability of industrial operations.

Delivered in various packing sizes, the AdsoMax Activated Alumina will meet customer needs when it's time for desiccant replacement.



AdsoMax Molecular Sieve

Desiccant for Compressed Air and Adsorption Dryers



Regular regeneration of molecular sieves is necessary to maintain their efficiency. This involves heating the bed to release the trapped moisture and contaminants, restoring the material's adsorption capacity. The versatility, reliability, and eco-friendliness of molecular sieves make them indispensable tools in ensuring the purity, safety, and quality of air and gas streams in a wide range of industrial processes.

The Molecular sieve is delivered in various packing sizes depending on the customer needs

Molecular sieves play a crucial role in air and gas drying applications by efficiently removing moisture and unwanted contaminants from the incoming streams. These highly porous materials consist of an intricate network of uniform-sized pores, allowing them to selectively adsorb water molecules and other impurities while letting the dry air or gas pass through.

In air and gas dryers, molecular sieves operate through a process called adsorption. As the moist or impure air enters the system, the molecular sieve bed captures water vapor and undesirable gases within its pores. This results in a substantial reduction in humidity and the removal of harmful components, ensuring the outgoing air or gas meets stringent quality standards.





Our offices



Kompauto Nordic AB

Fläderstigen 1
771 43 Ludvika
Sweden

Tel. +46 (0)10 130 10 00



Kompauto Norway AS

Ytrebygdsvegen 37
5251 Søreidgrend
Norway

Tel. +47 55 55 86 99

sales@kompauto.com
www.kompauto.com



INSTRUMENTS
VALVES